

भारत सरकार
अन्तरिक्ष विभाग
सतीश धवन अन्तरिक्ष केन्द्र
शार
श्रीहरिकोटा रेंज डा.घ.524 124,
नेल्लूर जिल्ला, आंध्र., भारत
टेलिफोन: +91-8623-245060 (10 जं)
फेक्स: +91-8623-225160



Government of India
Department of Space
Satish Dhawan Space Centre
SHAR
Sriharikota Range P.O. 524 121,
Nellore Dist., A.P., India
Telephones : +91-8623-245060 (10 Lines)
Fax : +91-8623-225160

TENDER NOTICE NO. SDSC SHAR/Sr.HPS/PT/SPP/05/2019-2020

On behalf of President of India, Sr. Head Purchase and Stores, SDSC SHAR, SRIHARIKOTA invites **on line quotations** for the following.

SI No	Ref. No.	Description	Qty.
01	SHAR SPP 2019 0 1135101 e-procurement [Single Part basis]	Supply of Electric Hoist with Electric Trolley	1 Lot
02	SHAR SPP 2019 0 1176802 e-procurement [Two Part basis]	Realization of Hydraulic lift	1 Lot

Last Date for downloading of tender documents : 21.10.2019 at 16:00 hrs.
Due Date for submission of bids online : 21.10.2019 at 16:00 hrs.
Due Date for Bid Sealing on : 21.10.2019 at 16:01 hrs. to 21.10.2019 at 17.30 hrs.
Due Date for Open Authorization : 21.10.2019 at 17.31 hrs. to 23.10.2019 at 16:00 hrs.
Due Date for opening of tenders : 25.10.2019 at 14:30 hrs.

Instructions to Tenderers:

No tender fee and EMD shall be applicable for tenders submitted through EGPS

01. For full details/scope of work and terms and conditions etc., please see the enclosed annexures.
02. Interested tenderers can download the e-tender from ISRO e-procurement website <https://eprocure.isro.gov.in> and submit the offer on line in the e-procurement portal. Offers sent physically by post/courier/in person will not be considered.
03. Tender documents are also available on ISRO website www.isro.gov.in ISRO e-procurement website <https://eprocure.isro.gov.in> and SDSC SHAR, Sriharikota website www.shar.gov.in. The same can be down loaded and offer submitted on line in the e-procurement portal.
04. Quotations received after the due date/time will not be considered.
05. The tender documents are available for download upto **21.10.2019 at 1600 hrs.** and last date for submission of tenders on line **21.10.2019 at 1600 hrs.** and Tender Opening on **25.10.2019 at 14:30 hrs.**
06. Sr. Head, Purchase and Stores, SDSC-SHAR, Sriharikota reserves the right to accept or reject any/or all the quotations.

DT: 24.09.2019

Sr. HEAD, PURCHASE AND STORES

Tender specification
**Fabrication, transportation, erection and commissioning
of Hydraulic Lift**



Satish Dhawan Space Centre SHAR

Indian Space Research Organisation

Sriharikota

Table of Contents

1.	Scope of this Tender	2
1.1.	Introduction.....	3
2.	General Terms and conditions	3
2.1.	Instruction to supplier	3
2.2.	Publicity Relating To Purchase order	5
2.3.	Arbitration	5
2.4.	Applicable law and jurisdiction.....	6
2.5.	Validity of Offer	6
2.6.	Cost of Bidding	6
2.7.	Income tax.....	6
2.8.	Project Monitoring.....	6
2.9.	Performance bank guarantee.....	7
2.10.	Liquidated damage.....	7
2.11.	Security deposit	7
2.12.	Force Majeure	8
2.13.	Guarantee.....	8
2.14.	Payment Terms	8
2.15.	Delivery	8
2.16.	Packing & Forwarding.....	9
2.17.	Exclusion of Tenders.....	9
2.18.	Documents Comprising the Bid.....	9
2.19.	On-line bids shall consist of the following:	9
	Part – I Technical and Un priced Commercial Part	9
	Part – II Priced Commercial Bid	10
2.20.	Bid Submission.....	10
2.21.	Bid Evaluation	11
3.	General Description	12
3.1.	Hydraulic lift.....	12
3.2.	Design requirement.....	14
3.3.	Services to be provided by the department	21
3.4.	Services to be provided by the supplier.....	21
3.5.	Tests required to qualify the hydraulic lift at our site.....	21
4.	Painting.....	22
5.	Summary of Data to Be Furnished by Party	22
5.1.	Data to Be Furnished By Party after placement of order	22
6.	TECHNICAL SPECIFICATION OF ELECTRICAL SYSTEMS....	24
7.	List of preferred Make/Vendors for Supply of Hydraulic Lift .	34

List of figures

<i>Fig. 1.</i>	<i>Lift location inside casting pit (Top View)</i>	<i>12</i>
<i>Fig. 2.</i>	<i>Lift location inside casting pit (Elevation).....</i>	<i>13</i>

1. Scope of this Tender

1.1. Introduction

- 1.1.1. SDSC SHAR is planning to realize a hydraulic lift.
- 1.1.2. The scope of work under this tender covers design, manufacture, testing, inspection at manufacturer's work, painting, forwarding, transportation to place of erection, unloading, storing the materials till the time of erection, erection and commissioning at our site, carrying out performance testing required for commissioning of hydraulic lift at Production Plant, SDSC SHAR.

2. General Terms and conditions

2.1. Instruction to supplier

- 2.1.1. Supplier shall submit project execution plan and work break down chart, detailing the methodology of execution (process plan) within 1 month from the date of issue of purchase order.
- 2.1.2. Supplier should award any part of the work under the scope of this purchase order to any sub vendor only after obtaining necessary approval from the department. Supplier shall submit relevant information as required by the department. Department has every right to accept or reject the proposal submitted. Approval of the department is no way relieves the supplier from his responsibility and the supplier is wholly responsible for execution of work as per the specifications, terms, and conditions mentioned in this document.
- 2.1.3. Supplier shall indicate clearly such of those works planned to offload to his sub-vendor.
- 2.1.4. The erection works at this facility requires that, the party shall adhere to good daily housekeeping practices. During erection, the party shall keep all work and storage areas used by them free from accumulation of waste materials. Scrap shall be removed from the site to the satisfaction of the purchaser.
- 2.1.5. Satish Dhawan Space Centre – SHAR (SDSC-SHAR) Sriharikota is declared as prohibited place under official secrets act 1923. Hence during execution of site works necessary security requirements enforced by the department from time to time shall be followed strictly.
- 2.1.6. SDSC SHAR shall have the right of inspection and supervision of the manufacturing process adopted by the Supplier for the manufacture of equipment at various

stages through their authorized representatives. In case the manufacturing process adopted is not found suitable and commensurate with the desired quality of the equipment, the Supplier will be advised to adopt the correct manufacturing process which will be binding on the Supplier. SDSC SHAR's decision regarding the quality of work and its acceptability shall be final and binding on the Supplier.

- 2.1.7. Defects in the material like fractures, cracks, blow holes, laminations, pitting, etc., are not allowed
- 2.1.8. Cost quoted shall be firm and fixed. Quote shall be on F.O.R. Sriharikota basis
- 2.1.9. Taxes (like GST etc.) applicable shall be indicated clearly in quotation.
- 2.1.10. Price shall be quoted in Rupees (INR).
- 2.1.11. Anchor fasteners shall not be used on brick/RCC wall. Brackets/EP, provided on wall shall be used for supporting lift.
- 2.1.12. During the erection, testing and commissioning of hydraulic lift at site in Sriharikota, the supplier has to make his own arrangements for boarding, lodging and transportation of his men and materials. However, subjected to availability, hostel accommodation may be provided by the Purchaser (SDSC SHAR) on chargeable basis.
- 2.1.13. Free electricity and water will be provided by the Purchaser (SDSC SHAR) for the erection, testing and commissioning works at the site.
- 2.1.14. Before starting the site work (at SDSC SHAR), the party shall provide insurance to all his personnel working at site in Sriharikota against accidents. Till commissioning of lift, the safe storing and handling of lift is in the scope of supplier. Insurance for the same shall be borne by the party and shall be included in the cost.
- 2.1.15. The transfer of title of hydraulic lift to the Purchaser (SDSC SHAR) will take place only after satisfactory erection, testing and commissioning of the hydraulic lift by the supplier and full acceptance by the Purchaser (SDSC SHAR).
- 2.1.16. Transportation & Transit Insurance are fully in the scope of supplier and the same shall be borne by the party.

- 2.1.17. The bidder shall clearly indicate the percentage of **GST** applicable against each case in their bid.
- 2.1.18. For standard bought out components whose details are furnished in this document in the form of preferred vendor list (**clause no.7**), the supplier shall adhere to the respective makes only. If Party proposes any other make, in such case, party shall bring out relative merits w.r.t each of the specification. In such case, department has right to accept or reject.

2.2. Publicity Relating To Purchase order

- 2.2.1. Advertisements, press release or other specialized publicity documents, which are related to or reveal the existence of a order and are intended by the Supplier for public distribution and/or the press, broadcasting, or television, shall be cleared/approved by the Department.
- 2.2.2. The Department may direct the Supplier to withhold such publicity or to require modifications to the publicity material. The Supplier shall comply with such direction.

2.3. Arbitration

2.3.1 In the event of any dispute/s, difference/s or claim/s arising out of or relating to the interpretation and application of the Contract, such dispute/s or difference/s or claim/s shall be settled amicably by mutual consultations of the good Offices of the respective Parties and recognizing their mutual interests attempt to reach a solution satisfactory to both the parties. If such a resolution is not possible, within 30 days from the date of receipt of written notice of the existence of such dispute/s, then the unresolved dispute/s or difference/s or claim/s shall be referred to the Sole Arbitrator appointed by the Parties by mutual consent in accordance with the rules and procedures of Arbitration and Conciliation Act 1996 as amended from time to time. The arbitration shall be conducted in Bengaluru in the Arbitration and Conciliation Centre –Bengaluru (Domestic and International) as per its rules and regulations. The expenses for the Arbitration shall be shared equally or as may be determined by the Arbitrator. The considered and written decision of the Arbitrator shall be final and binding between the Parties. The applicable language for Arbitration shall be “English” only.

Work under the Contract shall be continued by the CONTRACTOR during the pendency of arbitration proceedings, without prejudice to a final adjustment in accordance with the decision of the Arbitrator unless otherwise directed in writing by the DEPARTMENT or unless the matter

is such that the works cannot be possibly continued until the decision (whether final or interim) of the Arbitrator is obtained.

2.4. Applicable law and jurisdiction

- 2.4.1. The laws of India shall govern this contract for the time being in force. The Courts of Andhra Pradesh, India only shall have jurisdiction to be with and decide any legal matters or disputes what so ever arising out of the contract.

2.5. Validity of Offer

- 2.5.1. Bid shall remain valid for a period of **SIX months** from the due date of submission of the Bid.
- 2.5.2. The Bidder shall not be entitled during the said period to revoke or cancel his Bid or to vary the Bid except and to the extent required by Department in writing.
- 2.5.3. Bid shall be re-validated for extended period as required by Department in writing.
- 2.5.4. In such cases, unless otherwise specified, it is understood that validity is sought and provided without varying either the quoted price or any other terms and conditions of Bid finalized till that time.

2.6. Cost of Bidding

- 2.6.1. All direct and indirect costs associated with the preparation and submission of Bid shall be to Bidder's account and the Department will in no case be responsible or liable for those costs, regardless of the conduct or outcome of the Bid process.

2.7. Income tax

- 2.7.1. Income tax at the prevailing rate as applicable and if applicable from time to time shall be deducted from the supplier's bills as per Income Tax Act and a certificate issued (TDS Certificate).

2.8. Project Monitoring

- 2.8.1. Bidder shall submit the status report every 15 days mentioning the status of various activities w.r.t. planned schedule for realization of the items.
- 2.8.2. Bidder shall depute their Project team/ engineers for meetings to review the status and discuss/ resolve minor issues related to project execution at SDSC SHAR/ bidder's

site based on mutual agreement on mutually agreeable dates.

2.9. Performance bank guarantee

Towards the performance of the systems during the warranty period you shall submit a performance bank guarantee equivalent to 10% of the order value through bank guarantee from any of the Scheduled Banks executed on Rs.200 non-judicial stamp paper to cover the warranty period. This PBG shall be interest free and the same shall be returned to you on successful completion of all contractual obligations. The said PBG shall have a further claim period of 60 days after expiry of warranty period.

2.10. Liquidated damage

2.10.1. Time is the essence of this order. If the bidder's defined scope of work is not made by the end of delivery period, liquidated damage will be levied @ 0.5 % per week or part thereof subject to a maximum of 10% of value of undelivered stores. Bids received without compliance to this clause will be rejected.

2.11. Security deposit

- 2.11.1. On acceptance of the order, you shall submit an interest free amount equivalent to 10% of the total contract/order value towards security deposit. This security deposit is collected towards the performance of the Contract. Security Deposit shall be obtained through Bank Guarantee or fixed deposit receipt from any of the Scheduled Banks executed on non-judicial stamp paper of appropriate value, and shall be valid for a period of sixty days beyond the date of acceptance.
- 2.11.2. In case the bidder fails to furnish the security deposit within the specified date or extended due date, the Purchase Order/Contract shall be cancelled, and the EMD, if any, made earlier shall be forfeited, and, in addition, appropriate penal action will be considered.
- 2.11.3. Central PSUs/PSEs/Autonomous Bodies shall be exempted from the payment of Security Deposit, and instead, an Indemnity Bond shall be submitted by them in lieu of the Security Deposit.

2.12. Force Majeure

- 2.12.1. Should a part or whole work covered under this agreement be delayed due to reasons of Force Majeure which shall include legal lockouts, strikes, riots, civil commotion, fire accident, quarantines, epidemic, acts of God and Government, fright embargoes, the completion period for work, plant or equipment referred to in this agreement be extended by a period not in excess of the duration of such Force Majeure. The occurrence shall be notified by either party within reasonable time.

2.13. Guarantee

- 2.13.1. The hydraulic lift shall be guaranteed against any manufacturing defects for a period of 12 months from the date of commissioning. If any defects are noticed during the above period, the same shall be rectified/replaced at free of cost.
- 2.13.2. Party shall check performance and carry out preventive maintenance of lift **twice during guarantee period.**

2.14. Payment Terms

- 2.14.1. Our standard payment term is 100% within 30 days after receipt and acceptance of individual items at SDSC SHAR and submission of PBG as per clause no. 2.9.
- 2.14.2. Wherever payment of advance is considered necessary or unavoidable, it is allowed at 10% minimum to maximum 30% to private firms after getting an acceptable Bank Guarantee or 40% to State/Central Govt. Agencies/PSUs against Indemnity Bond
- 2.14.3. In case of advance payments, if the bidder is not supplying the material within the delivery schedule, interest will be levied as per the Bank Lending Rate plus 2% penal interest.
- 2.14.4. Interest will be loaded for advance payments/stage payments as per the lending rate of Bank and will be added to the landed cost for comparison purpose if required. In case of different milestone payments submitted by the parties, a standard and transparent methodology like NPV will be adopted for evaluating the offers.

2.15. Delivery

- 2.15.1. The hydraulic lift sub systems shall be supplied within **Four months** from the date of award of purchase order.
- 2.15.2. Erection and commissioning shall be completed within **Two month** from the date of all site clearances.

2.16. Packing & Forwarding

- 2.16.1. The bidder will be held responsible for the items being sufficiently and properly packed for transport by rail, road, sea or air, to withstand transit hazards and ensure safe arrival at the destination. The packing and marking of packages shall be done by and at the expenses of the Contractor.

2.17. Exclusion of Tenders

The following tenders shall be summarily rejected from the procurement process:

- 2.17.1. Tenders of bidders who have been removed from the vendor list or banned/debarred from having business dealings.
- 2.17.2. The tenders which depart from the requirements specified in the tender document or which contain false information.
- 2.17.3. Tenders of bidders who don't meet the bidder qualification requirement given in Annexure – 1.
- 2.17.4. Tenders of bidders who don't submit the compliance statement.

2.18. Documents Comprising the Bid

This is e-procurement tender. All the documents need to be scanned and attached to the bid under "documents solicited from bidder" form.

- 2.18.1. Offers shall be sent online only using standard digital signature certificate of class III with encryption / decryption. The tenders authorized online on or before the open authorization date and time only will be considered as valid tenders even though the bids are submitted online.
- 2.18.2. The bidder must authorize bid opening within the time stipulated in the schedule. Otherwise the online bid submitted will not be considered for evaluation.

2.19. On-line bids shall consist of the following:

Part – I Technical and Un priced Commercial Part

- 2.19.1. Technical and un-priced commercial part shall comprise the following documents/information. All the documents

shall be scanned and uploaded in the ISRO e-procurement portal.

- 2.19.2. Submission of bid letter along with one set of tender document duly signed and stamped as token of acceptance. Scanned copy shall be uploaded in the ISRO e-procurement portal.
- 2.19.3. Any other relevant document, bidder desires to submit.
- 2.19.4. Confirmation w.r.t bid qualification criteria as per Annexure-1.
- 2.19.5. Compliance statement as per Annexure-2.
- 2.19.6. Deviations, if any, w.r.t technical and commercial terms & conditions shall be clearly brought out under deviation list Annexure-3. If deviations are not listed in the given format, it will be presumed that the bidder is adhering to all the specification and terms & conditions given in this document. Deviations listed elsewhere in the tender document will not be considered
- 2.19.7. Confirmation w.r.t price bid schedule as per Annexure-4.

Note: All the above documents shall be uploaded in the ISRO e-procurement portal.

Part – II Priced Commercial Bid

- 2.19.8. Priced commercial bid shall contain schedule of prices and shall be filled in ISRO e-procurement portal. No deviations, terms and conditions, assumptions, discounts etc. shall be stipulated in price bid. Department will not take cognisance of any such statement and may at their discretion reject such bids.

2.20. Bid Submission

- 2.20.1. Bid shall be submitted in two parts
- 2.20.2. **Part -1** Techno-Commercial Part of the Bid
- 2.20.3. **Part-2** Price Part of the Bid
- 2.20.4. Offers should be submitted On-line using standard digital signature of class -3 with encryption/decryption options.
- 2.20.5. The tenders authorized online on or before the open authorization date and time will only be considered as valid tenders.
- 2.20.6. Prices shall be mentioned in the space/column provided in the ISRO e-procurement portal only for such purpose.

- 2.20.7. Physical copy of the bid will be accepted only in case if the file size is bigger and not possible to upload the same. In such case, the hard copy shall be submitted within due date. Documents received after due date will not be considered.
- 2.20.8. Prices quoted should be on F.O.R. Sriharikota basis.
- 2.20.9. The Department will not pay separately for transit insurance and same shall be included in the cost quoted by the Bidder.
- 2.20.10. All risks in transit shall be exclusively borne by the contractor. The department shall pay only for such items that are actually received in good condition in accordance with the purchase order.
- 2.20.11. Bids duly filled in by the Bidder should invariably be submitted as stipulated in the e-procurement portal.
- 2.20.12. Department shall open Part – I of the bid on the due date of opening. Price Bid (Part-II) of the technically and commercially acceptable bids shall be opened at a later date. The same will be intimated to the qualified bidders.
- 2.20.13. Department reserves the right to reject any or all the Bids without assigning any reasons thereof.

2.21. Bid Evaluation

- 2.21.1. **Overall L1 for all items as listed in this tender will be considered for placement of purchase order.**
- 2.21.2. The bidder shall provide all the relevant data/information/details required for evaluating the bid technical and commercially in the specific formats enclosed with the tender. Apart from this, Bidder is free to add any other relevant information.
- 2.21.3. During evaluation, Department may request Bidder for any clarification on the bid/ additional documents/ information required. Bidder shall submit all clarifications/ additional documents/ information requested in original. If not submitted within the stipulated time department has right to reject such bids.
- 2.21.4. The complete scope of work is defined in the Tender document.
- 2.21.5. In case Bid does not fully comply with the requirement of Tender document and the bidder stipulates deviations to the clauses of the tender, which are unacceptable to the

Department, the Bid will be rejected.

- 2.21.6. Performance of Bidder on similar nature of works executed/ under execution shall be taken into consideration before selecting the Bidder for opening his price bid.
- 2.21.7. The time schedule for completion is given in the Tender document. Bidder is required to confirm the completion period unconditionally

3. General Description

3.1. Hydraulic lift

To reach the casting pit bottom level (19m from finished floor level), a hydraulically operated passenger lift is to be provided. The lift shall be installed inside a pit. Permanent hydraulic lines shall be routed from power pack to lift operating cylinder. Lift shall have three landings with operating push button at all the three levels and inside the cabin. The overall layout of pit is shown below:-

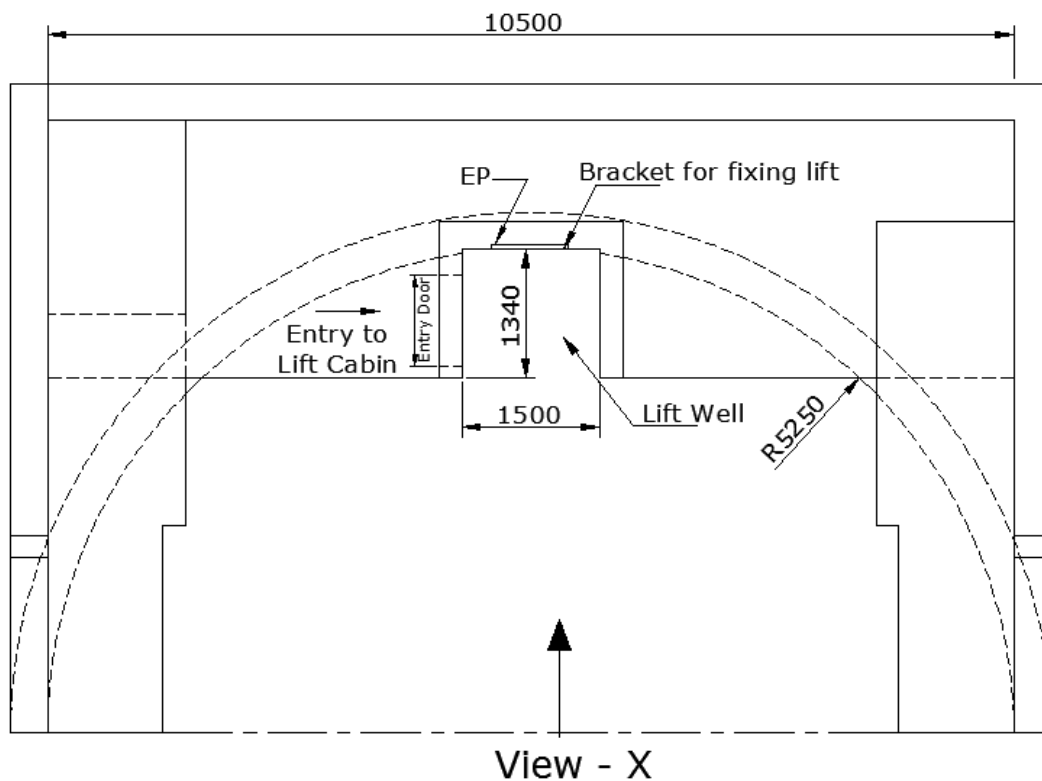
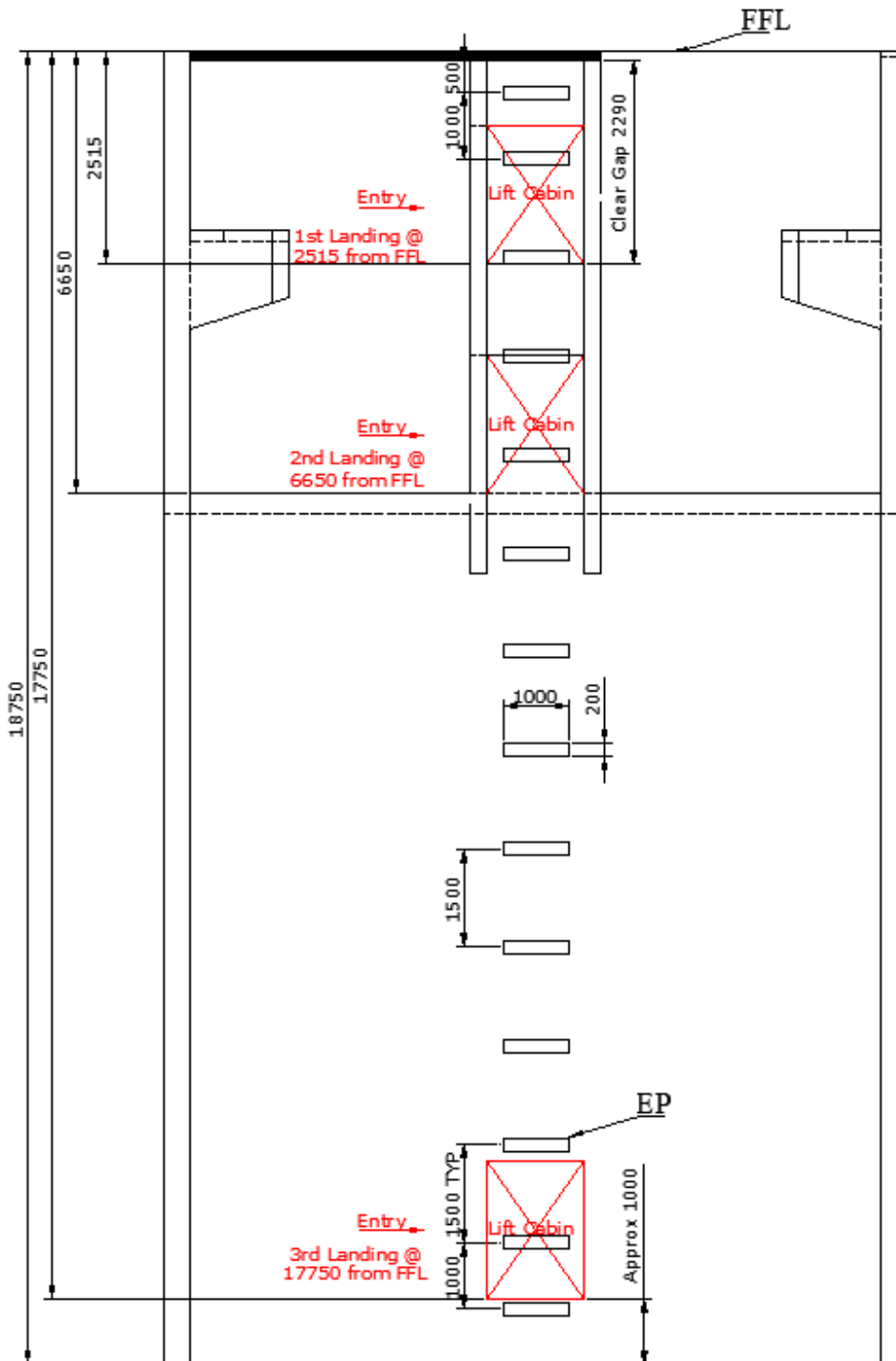

Fig. 1. Lift location inside casting pit (Top View)



View from - X

Fig. 2. Lift location inside casting pit (Elevation)

3.2. Design requirement

Sl. No.	Description	Specification
1)	Location	Casting Pit
2)	Type of lift	Passenger Lift (Hydraulically operated indirect acting lift)
3)	Corrosive location	Coastal area.
4)	Capacity of lift	The lift capacity shall be minimum 300 kg.
5)	Lift	Lift shall be located in Hazardous area (Zone-1, Gas group IIA/IIB, T4). Hydraulic power pack shall be located at safe area in finished floor level (FFL), at a distance of about approx. 70m away from lift.
6)	Power pack	Standard power pack of reputed make as per preferred vendor list (clause no.7 of this tender document) shall be used. Power pack shall have standard items like Pressure relief valves, pressure line filter, return line filter, reservoir, air breather, hydraulic pump, etc.
7)	Hand Pump	Hand pump shall be provided for manual operation of lift (upward movement).

8)	Pipe line routing	Permanent SS hydraulic tubes of suitable rating shall be used. Hydraulic tube shall be run from power pack to lift over standard supports. Flexible hoses shall be used for min distance only. Party shall provide standard supports for hydraulic line routing. Size of the tubing shall be worked out based on the power pack location and distance of lift from power pack so that back pressure is minimised.
9)	Cabin size	1050mm X 900mm or nearest standard based on the available clear gaps at site. Party shall try to maximize the size of cabin during detailed engineering.
10)	Lift well size	Max clear gap 1300mm (Width) X 1450mm (Depth)
11)	Travel of lift	15.2m(approx.)
12)	Speed	0.3 to 0.5 m/sec or as per standard
13)	No of landings	3
14)	Location of landings	<ul style="list-style-type: none"> • First landing @ 2.515 below FFL • Intermediate landing @ 6.650m below FFL • Last landing @ 17.750m below FFL
15)	Landing Call & Car Callbutton	<ul style="list-style-type: none"> • At each landing and also inside cabin

16)	Type of door	Cabin door - Stainless Steel Manual telescopic/sliding door with vision glass panel. Landing door - Stainless Steel Manual telescopic/sliding door with vision glass panel.
17)	Material of construction	Stainless Steel 304 for Cabin inside and all entry doors and door frame.
18)	Cabin interior Finish	Matt finish
19)	Clear gap between 1 st landing and finished floor level(FFL)	2.290m.
20)	Pit depth below the last landing	1m approx.(Shall be optimised)
21)	Fixtures inside car	<ul style="list-style-type: none"> • SS hand rail • False ceiling (SS)
22)	Illumination inside cabin	Flameproof, LED light fittings
23)	Operating devices	<p>In the Lift Car: call buttons for G (first landing), -1(intermediate landing), -2(last landing), Alarm, light on /off, Emergency Stop), Key operated Selector for Attendant.</p> <p>At the landing: call button for up, down, emergency stop and etc.</p> <p>Minor changes required to ensure safe operation of lift shall be incorporated during detail engineering at no extra cost.</p>

24)	Lowering of lift in case of failure.	Necessary Provision shall be made on power pack for lowering the lift to next level in case of power failure. Also provision for opening the landing door in case of emergency shall be provided.
25)	Automatic rescue device (ARD)	ARD shall be provided. During power failure provision shall be made to facilitate the lift to reach at next nearest level (down only). UPS and other accessories required for operation of ARD shall be provided.
26)	Rupture valve mechanism	Rupture valve mechanism shall be provided. Rupture valve shall be capable for stopping the car in down ward movement and maintaining it stationary. Rupture valve shall be tripped when speed reaches rated speed downward plus 0.3 m/s.
27)	Buffer (A resilient stop at the end of travel and comprising by means of braking using spring)	Buffer shall be provided.
28)	Factor of safety (F.O.S)	Suspension rope for car: 12 (min) Flexible hose : 8 (min) Jack /cylinder: 1.7(min)
29)	Suspension rope nominal dia	Rope nominal dia shall be finalized considering the F.O.S of rope 12(min)
30)	Protection against overheating of the hydraulic fluid	Temp detecting device shall be provided on power pack. The device shall trip the power pack.
31)	Non return valve	A non-return valve shall be provided. It shall be installed in the circuit.

32)	Down direction valves	Down direction valve shall be provided. It is an electrically controlled valve in a hydraulic circuit for controlling the descent of the car.
33)	Shut-off valve	Shut-off valve shall be provided. It shall be installed in the circuit which connects the cylinder to the non-return valve and down direction valve
34)	Electrical anti creep system	<p>Electrical anti creep system shall be provided which satisfies the following condition:</p> <ul style="list-style-type: none"> • The machine shall be energized in the up direction independent of the position of the door, when car in a zone which extends from maximum 0.12m below the landing level to the lower end of the unlocking zone • The car shall be dispatched automatically to the lowest landing within 15 min after the last normal journey (when doors are closed)
35)	Minimum number of rope	2 per jack.
36)	Overload indicator	Car shall be provided with overload indicator and shall be interlocked with operation of lift. This indicator shall be designed to operate through intrinsic safe relay.

37)	Display	Fluorescent instructions including Do's and Don'ts shall be indicated on stainless steel plate. The instructions shall include basic instructions and response to various conditions likely to be encountered in the lift such as (but not limited to): -Action to be taken in case of getting stuck-up in the lift.
38)	Power supply	415V, 3-Ph, 4-W, 50Hz
39)	Electrical fittings inside lift	<ol style="list-style-type: none"> 1. All the electrical fittings like light etc shall be suitable to use in Hazardous area. 2. All light fittings shall be mounted on the car top and hooter shall be positioned at safe area, 65m away from the lift. 3. FLP Junction box to be provided for routing the power cable. 4. Junction box location shall be finalised during detailed engineering.
40)	Call point /Push button station	All Service Call point/push button stations (including the sl. no. 23, 44 & 45 of this table) shall be provided with Intrinsic Safe operation relays. The aysthetic point to be considered while selecting this Call point / push button station (both inside and in each landing). The same to be finalized during detailed engineering. The supplier can use standard reputed make and at the same time it is to be operated through intrinsic safe relay/circuit.

41)	Protection devices/ control cards.	All protection devices / control cards shall be provided inside electrical panel itself.
42)	Digital input/ digital output relay	All the field signals are to be routed through digital input or digital output Intrinsic Safe relays.
43)	Operating button details	<p><u>Landing Call Panel:</u> Call button for up, down, emergency stop and etc</p> <p><u>Car Call Panel:</u> Buttons for G (first landing),-1(intermediate landing),-2(last landing), light, alarm and etc.</p> <p><u>Electrical Panel:</u> Buttons for Maintenance.</p> <p>Minor changes required to ensure safe operation of lift shall be incorporated during detail engineering at no extra cost.</p>
44)	Limit switches & Indication lamps.	<p>Level switch – 2 (1 Main + 1 Redundant)</p> <p>Door zone -2 (1 Main + 1 Redundant)</p> <p>Top limit switch – 2 (1 Main + 1 Redundant)</p> <p>Bottom limit switch – 2 (1 Main + 1 Redundant)</p> <p>Indication lamp (cluster LED type) / indicator (LCD Display)</p> <p>Intrinsically safe self-illuminated P.B if it is selected for this application</p>
45)	Staircase	Party shall provide structural staircase from last landing of lift to pit bottom (approx 1m). Staircase shall be fabricated after completion of erection of lift at site.

46)	Cage around lift	At last landing, structural cage all around lift shall be provided (side walls are not available at pit bottom). Swing doors shall be provided to access the lift for carrying out maintenance works. Cage shall be fabricated at site after erection of lift. Cage shall be painted as per specification given in this document.
47)	<i>Electrical</i> requirement	Refer clause no.6 of this tender document.
48)	Standards	Lift shall comply with IS 14665 and EN 81.2/ASME 17.1. If the party complying with any other equivalent standards, the same shall be indicated clearly.

3.3. Services to be provided by the department

- 3.3.1. Civil structure
- 3.3.2. Electricity/water will be provided free of cost during erection at site. Power shall be provided at a fixed location. From there, party shall arrange necessary cables for taking up power to required location.

3.4. Services to be provided by the supplier

- 3.4.1. Erection and commissioning of lift
- 3.4.2. Load testing and demonstration of all the safety features. Test load will be provided by the Department.
- 3.4.3. Equipments like welding machine/gas cutting/grinding etc and hand tools required during erection at site.
- 3.4.4. Necessary arrangement (all tools and other accessories) required to carry out free fall test of lift.
- 3.4.5. Following Spares shall be supplied along with the item,
 - PLC – 1No
 - SMPS – 1 No
 - 2 sets of oil seals (seal kit)
 - 2 suction filters.
 - 1 Set of used switch gears inside the panel

3.5. Tests required to qualify the hydraulic lift at our site

- 3.5.1. DP test shall be carried for root and final welds that are carried out at our site during erection works. Reports shall be submitted.
- 3.5.2. Operational checks shall be carried out like up/ down and stop at all landings etc.
- 3.5.3. Load test shall be carried out at 1.25 times SWL.
- 3.5.4. Performance check of emergency lever available on power pack, for lowering the lift to next landing in case of power failure.
- 3.5.5. Performance check of all the in-build safety systems like overload indicator, ARD, Manual lowering, Operation with hand pump etc. shall be carried out.
- 3.5.6. Speed measurement shall be carried out at no load and full load.
- 3.5.7. Current drawn by HPP motor at full load (SWL) operation shall be within 80% of rated current.

4. Painting

All the exposed carbon steel surfaces/structural steel shall be painted as per following:-

- Surface Preparation: Cleaning by wire brush or power tools to remove any loose dirt or mill scales from the surface. Sand blasting shall be carried to clean the inner and outer surface before painting operation.
- Primer: One coat of zinc rich primer with red oxide and zinc phosphate pigments to achieve total DFT of 70 to 75 micron.
- Final Coat: Two coats of epoxy paint of total 125 micron DFT. (Shade shall be approved by Department)
- Spray Painting shall be carried out. All the items required for painting shall be arranged by the Party.

5. Summary of Data to Be Furnished by Party

5.1. Data to Be Furnished By Party after placement of order

- 5.1.1. Party shall submit lift general arrangement drawing showing the interface details within **two weeks** from the date of placement of purchase order.
- 5.1.2. Drawings submitted by the Party for approval shall be checked/reviewed by the PURCHASER and comments, if

any, on the same will be conveyed to the Party. Party shall incorporate all these comments in his drawings.

- 5.1.3. Hydraulic circuit diagram
- 5.1.4. Electrical circuit diagram
- 5.1.5. Party shall send copies of instruction manuals along with the dispatch of equipment. Instruction manual shall contain full details, as-build drawings of all equipment, erection procedure, testing procedure, operation & **periodical maintenance** procedure of the equipment. If after commissioning and initial operation of the equipment, the instruction manuals require any modifications/additions the same shall be incorporated and the updated instruction manuals shall be submitted by the Party to Purchaser.
- 5.1.6. Quality Assurance Plan
- 5.1.7. Un priced copy Purchase orders for bought out components
- 5.1.8. Erection Plan
- 5.1.9. Inspection and Testing Plan
- 5.1.10. Commissioning Plan
- 5.1.11. Dimensional inspection reports generated during entire fabrication process, erection and commissioning.
- 5.1.12. List of Spares required for two years of preventive maintenance.
- 5.1.13. All the reports generated during fabrication including material test certificates and other NDT tests like DP test on root and final welds of fabricated structures.
- 5.1.14. Final as built drawings, 2 sets hard copy and 2 sets of manuals.

6. TECHNICAL SPECIFICATION OF ELECTRICAL SYSTEMS SCOPE OF WORK TO THE SUPPLIER

- Design, Fabrication and supply of Elevator Control Panel (ECP).
- Testing and commissioning of above Elevator Control Panel (ECP).
- Erection of the Elevator Control Panel (ECP) and interconnecting of field control wiring, etc to the above panel **are in the scope of Supplier.**

DETAILED TECHNICAL SPECIFICATIONS FOR ECP

General description:

Supply, Testing & Commissioning of front operated indoor cubicle type free standing Elevator Control Panel (ECP) suitable for operation on 415V, 3-Phase, 4 wire, 50 Hz, AC Supply system.

The *ECP* shall be designed for operation in high ambient temperature up to 50°C, high relative humidity up to 95 % and tropical atmospheric condition.

The panels and junction boxes shall be of M/s RITTAL/President make with the following:

- Panel Dimension: Width:800-1000 mm (min)
Height: 2000 mm (max)
Depth: 400 mm (min)
- Panel shall have a base / plinth frame of height 100 mm
- Panel shall be FAN ventilated type.
- Drawing pocket to be considered
- Comfort handles with key to be considered.

The panel with necessary anti-corrosive treatment and shall be of dust, damp and vermin proof construction (with IP-52).

Electrical Equipment Environment:

1. All Electrical equipments shall be supplied for tropical and humid climate (Temperature of 50°C & RH not less than 95%). De-rating of drive motors, power cables, Control electronics boards etc., shall be done for ambient temperature of 50°C.

2. The Elevator shall be equipped with flame proof electrical systems/Intrinsic safe controls suitable for operating in hazardous area classified as Zone 1, Gas group IIA/IIB, T4.
3. Flame proof electrical fittings and intrinsic safe controls shall be selected. For control circuit and I/Os which are connected to hazardous area to be routed through intrinsic safe modules.
4. The Electrical equipment shall conform to the latest Indian electricity rules and regulations as regards safety requirements, earthing and other essential provisions specified therein.
5. The power available (415Volts, 3phase, 4wire, 50Hz) at near by the ECP panel. The power and control equipment selected shall be suitable for operation on $\pm 10\%$ variation in the voltage and $\pm 3\%$ variation in supply frequency.
6. Power source available to tap for ECP panel (where main power source is located approximately 60m distance). Supply, laying and end-termination of 1100 V grade 4 C x Suitable sq.mm of copper conductor with armoured incoming cable.
7. For Push buttons, Indication lamps, limit switches in the field and all the interlocks to the field equipments: Intrinsic Safe Package Supply, to be used.
8. DSL for CAR UP / DOWN: All cables both power and control which are to be used in the CAR shall be routed through drag chain with guided cable tray only.

Elevator Control Panel:

1. This panel shall be located in a safe area.
2. Panel shall have the 3-phase indication lamps controlled by suitable rated MCB.
3. Control transformer can be planned for the control supply. Incoming and Outgoing MCBs shall also be planned for the control transformer.
4. Control transformer can be mounted inside the panel with suitable ventilating arrangement.
5. All the feeders control supply to be routed through the suitable / adequate rating MCB.
6. The panel shall have the sufficient no. of aux. Contactors for power contactor as per the circuit and operational requirement. No. multiplication of add-on NO, NC blocks are allowed. In case of requirement, the same to be multiplied with aux. contactor.

7. Minimum 20% spare NO, NC points shall be provided to the contactors for further future usage.
8. Four (4) operating modes (i.e. From *inside* CAR, inspection mode operation via push button station (location will be decided during detailed engineering), outside the car from landing location and from hydraulic power pack) shall be provided.
9. The ECP switchgears shall meet the control logic as described in the control, functional and safety requirements mentioned elsewhere or follow the standards elevator requirements with the approval of purchaser.
10. DOL starter shall be provided for all motors up to 25kW whereas Star Delta starter shall be provided for motors of 25kW and above.
11. All contacts / terminals of the switchgear components shall be wired to the terminal block.
12. For all design purposes ambient temperature shall be considered as 50deg C.
13. The bottom most row of equipment mounted inside the panel excepting terminal strip shall be at least 350mm above the panel bottom cover to facilitate inspection and repairs. All the terminal strip to be grouped with respect to the application and group marker to be provided as per the direction of purchaser.
14. A minimum clearance of 250mm shall be provided between the terminal strip and the panel bottom cover to facilitate cabling.
15. Suitable provision can be made for external routing the control cable and power cable with a distance of minimum 300mm.
16. The design shall ensure generous availability of space for ease of installation and maintenance of cabling and adequate safety for working.
17. The panel shall have high mechanical and dielectric strength.
18. Thermistor relay need to be considered and provided inside the ECP and the same shall be wired as an additional safety interlock in the motor circuit.

Moulded Case Circuit Breakers (MCCB):

1. The Incomer MCCBs shall be of three pole with full rated neutral version. It shall be supplied with shunt trip coil of 230V rating.
2. The MCCBs shall be supplied with Front-operated rotary operating mechanism along door-coupling rotary operating mechanism.
3. Operating handle in the MCCB shall be provided to indicate the position of the MCCB clearly such as 'OFF', 'ON' and 'Trip' position.
4. MCCB shall have a provision for adjustable overload and adjustable short circuit current rating.
5. The supplier is advised to use only the latest series MCCB in the circuit.

Motor Protection Circuit Breakers (MPCB):

1. The hydraulic motor feeder shall be provided with MPCB of adequate rating.
2. The MPCB shall be provided with side Auxiliary contacts blocks 1 NO and 1 NC.
3. The MPCB shall be provided with Alarm Contact cum Signalling Switch 1 NO + 1 NC.
4. Hydraulic motor trip indication lamps to be wired for the indication lamps/indicator. This indication lamps/indicator shall be provided in the ECP as well as CAR Call Panel (CCP) which is inside the CAR. In the CCP control should be carried out through intrinsic safe circuit.

Safety in Arrangements:

1. All electrical panels shall have finger touch protection, for human safety viz. working on one component shall not cause shock to the personnel due to any other live component in the panel. Also, the terminal live parts shall not be accessible by fingers (finger cannot come in contact with live parts of the terminals).
2. The apparatus and circuits in the EC panel shall be so arranged as to facilitate their operation and maintenance and at the same time to ensure the necessary degree of safety.
3. All the live parts to be covered properly (no live parts to be visible after opening the door) in order to avoid the possibility of inadvertent touching of the same during operation and maintenance.
4. Routing of all the control cables planned such a way that it should not cross any live parts.
5. All the insulated materials used in the construction of the panel shall be non-hygroscopic, duly treated to withstand the effect of

high humidity, high temperature, and tropical ambient service conditions.

6. The panel shall provide with double earthing.

Power and Control wiring:

1. All control wiring shall be carried out with 1100 V grade multi core insulated cable having stranded copper conductors of minimum 1.5 sq.mm section for Auxiliary circuits wherever voltage signals were used and minimum 2.5 sq.mm section for CT circuits.
2. All the power cables both incoming to the ECP and outgoing from the ECP are to be selected based on the motor rating and as per the guidance given by the department.
3. All the power cables shall be of 1100 Volts grade, XLPE insulated, confirming to IS:7098 (Part-1) 1988 with latest amendments, having stranded copper conductors, with colour coded insulation, Extruded black PVC inner sheath, single layer of galvanised steel strip / wire as armour and overall outer sheath of extruded black PVC.
4. All the cables are to be selected for copper conductor and armoured cables except the cable which is used for movement along with Elevator cabin.
5. All the control cables going to the field (ie., interfacing between Field JB and ECP) shall be selected for Multi-core and suitable size of sq.mm armoured cables as per the design or as per the department guidance to be selected.
6. Running a no. of cables to meet the no. of core requirement will not be approved/allowed.
7. All the internal power wiring shall be carried out using multi strand copper FRLS wire / cable of suitable capacity.
8. Wiring shall be neatly bunched, adequately supported, and properly routed through cable alley (duct) to allow easy access and maintenance.
9. Wires shall be identified by numbered ferrules at each end (preferably double cross ferrules).
10. The ferrules shall be of the ring type and of non-deteriorating material.

Terminal blocks and labels:

1. Terminal blocks shall be of 500 Volts grade of the stud type and shrouded.
2. Insulating barriers shall be provided between adjacent terminals.
3. Provisions shall be made for label inscriptions for the easy identification of terminal blocks (by means of numbering).
4. Group TBs can be planned with respect to the cleared control scheme. Group TBs are to be named clearly.
5. All the power terminals are to be selected for connecting the ring type lugs (in both panel and FLP junction boxes if required)
6. All the power terminals and live parts are to be covered with proper terminal covers.
7. Group terminal markers to be used for the clear identification.
8. All the power and control terminals are to be provided with suitable terminal numbers.
9. Power terminal blocks shall be separated from each by means of replaceable insulated spacers.
10. Component name plates shall be of acrylic engraved sheets only and same to be fixed by screws/rivets and shall not be pasted.
11. Minimum 30 % of spare terminal blocks to be provided as spare.

Pushbutton:

1. For CAR to have a control, Landing Call Panel (LCP), CAR Call Panel (CCP) which is inside the CAR and Inspection Call Panel (ICP) which location shall be finalised during detail engineering.
2. For the above said panel, the supplier can use their own button in their standard panel or normal push button placed on their panel.
3. If the supplier is used for their standard panel, it is to be ensured that the control for the same to be taken care for Intrinsic Safe circuit.

Indication lamps:

1. Indication lamps shall be provided for all 3 phases for the incomer.
2. At CAR landings, present CAR position indication to be planned.
3. Inside the CAR, present CAR position indication to be planned.
4. Indicating lamps shall be of Cluster LED type only, provided with translucent lamp covers.
5. All the indications Lamps are to be selected for the Intrinsic Safe Indication Lamps only except for the 3 phase indication lamps in the ECP incomer.

Proximity Sensor:

1. For DOOR Zone and Level detection limit switches to be considered for Intrinsic Safe proximity switch / sensors.
2. Each sensor mentioned for the above usage to be selected for two nos. instead of one no. to achieve the redundant and fail safe control of CAR.
3. Metal pieces are to be mounted / welded on the shaft or guided track to sense the above positions. **Magnet pieces are not to be used for the same.**
4. UP / DOWN limit switches are to be provided with Two Lever Type limit switches.

ONCAR:

1. Inside the CAR all the light fittings, etc are to be considered for Flame Proof systems only.
2. Light fittings are of LED type to be selected.
3. 1 No. of light fitting to be powered through ARD circuit.
4. Light fittings to be mounted on the top of the car with suitable clamping arrangement and no circumstances, the lights fittings to fall while the car is in travel.
5. Light fittings glass alone to be visible when looking the lights from inside the car.
6. Make of the Light fittings shall be M/s BALIGA Lighting Equipments Pvt. Ltd.

Junction Boxes:

1. Flame Proof junction boxes to be planned for the power supply to the lights.
2. Non-Flame Proof junction boxes to be planned for the circuit terminal which are controlled by the intrinsic safe circuit.
3. No. of inputs and outputs to be considered – Minimum 3Nos. of input and 3Nos. of output.
4. Stainless steel, double compression gland suitable for hazardous area to be considered for the flame proof junction box terminations.
5. **No control boards to be placed on the top of the CAR** except the terminals of intrinsic safe circuit inputs.

Motors:

1. The motor used for hydraulic pump is of **Energy Efficient Squirrel cage induction motors.**

2. Class of insulation - Class F
3. The motor shall be housed with inbuilt thermistor.
4. The Motor shall have preferably ZZ type bearings.
5. Details to be provided related to motor selection and calculations
 - a. Power of motor
 - b. Frame size
 - c. Make
 - d. No. of poles
 - e. Amb.temp etc.
6. Maximum Current drawn by the motor with full load should not exceed 80% of the full load rated current.

Earthing:

1. Earth Copper bus bars of minimum 75 Sq.mm (25 x 3 mm) size shall be provided throughout the length of the panel.
2. Earth bus bar shall be provided for power and instrumentation independently.
3. Power Earth bus should be running along the entire length of the panel.
4. Provision for connection to the plant earth grid shall be provided at both the ends of the panel.
5. Instrumentation earth bus can be provided in the both the sides of the panel.
6. All the earth connections to be linked to the corresponding earth bus within the panel itself.
7. Within the panel board all the switch gear bodies shall be duly connected to the earth bus bars.
8. All hinged doors with electrical accessories shall be provided with flexible copper earth connections.

Tests to be done at factory / works prior to despatch

Testing and commissioning at Factory (FAT):

1. The ECP panels shall be completely assembled, wired, and tested for operation under stimulated conditions to ensure correctness of wiring and interlocking and proper functioning of all components.

2. The ECP panels shall be tested for acceptance / routine tests as specified in the relevant latest Indian standards
3. The above tests shall be successfully carried out at factory as mentioned above with the presence of Department Engineers (CLIP) and necessary test certificates shall be enclosed along with despatch of panels in triplicate.

Subject to the clearance from Department after the satisfactory completion of above tests at factory / works shall only the panel can be despatched.

Testing and commissioning at Site (SAT):

During commissioning / energisation of the ECP panel, the supplier shall depute their supervisor and the following tests shall be conducted on the switch board at site prior to commissioning.

- a. Insulation resistance between the phases and individual phases and earth.
- b. Earth continuity checks.
- c. All the protective relays and tripping mechanism shall be checked for their proper operation and setting / grading shall be done as per the directions by department.
- d. Operation and functionality tests of the switch gear and interlock.
- e. The ECP panels along with CAR shall be tested for acceptance / routine tests as specified in the relevant latest Indian standards.
- f. No load, load testing shall be planned as per this document.

Note to supplier:

1. The ECP panel shall be supplied to SDSC SHAR, SRIHARIKOTA by the supplier. Department will provide material handling equipment required for unloading.
2. Motor run test and Routine test certificates shall be provided.

Special Terms and Conditions:

1. Parties should furnish detailed power, control with respect to individual card as well as for overall functionality, GA drawing and bill of quantity, with datasheets of bought out items and should obtain approval before starting fabrications.

2. All test facilities required shall be provided for the tests prescribed as above by the party without any additional cost at their factory.
3. On receipt of Purchase Order the agency shall be submitting the following drawings for approval before manufacturing:
 - i. Detailed Schematics of the ECP Panel and junction boxes.
 - ii. ECP general arrangement drawing.
 - iii. ECP control schematic drawing.
 - iv. Cable schedule from ECP to field and etc.
 - v. General arrangement drawings with all details including the make of all components, installation details etc.
 - vi. Foundation drawings.
 - vii. Control (individual card & overall functional)wiring drawings.
4. The party shall offer for stage inspection by Department Engineers.
5. The ECP panels, control cards and switchgears shall be guaranteed for a period of 12 months from the date of commissioning against manufacturing defects. The supplier shall repair / replace the damaged equipment without any extra cost during the guarantee period.
6. The supplier shall provide three complete sets of all the drawings, operation and maintenance manuals and test certificates for the operation and maintenance purpose of the department.
7. ECP Panel cubical keys, interlock keys, are to be handed over to department during supply.
8. The department shall reserve the right to accept / reject any part of work, which is not acceptable as healthy engineering practice of carrying out such work as the case may be.
9. In case of any failure to carry out the scope of work in time as per the instruction of department, the work shall be carried out / got done by the department at the cost and risk of the supplier and the entire amount with supervision charges shall be recovered from the supplier.

7. List of preferred Make/Vendors for Supply of Hydraulic Lift

Sl. No.	Category	Item Description	Preferred Make
1.	Hydraulic	All Direction control valves, rupture valve, NRV Flow control valves	Blain/Parker/Rexroth/Vickers/GMV/Moris
2.		Hydraulic Hoses	Markwell/Parker/Gates
3.		Hydraulic cylinder	Parker/Rexroth/Vickers/GMV/Moris
4.		Hydraulic Oil Pump, Hand pump	Settima/SIEM/Parker/Rexroth/Vickers/GMV
5.	Rope	Wire rope	Usha Martin
6.	Electrical/ Instrumentation	Level detector and door zone switches/Sensor	P&F
7.		Digital input or Digital output relays (Intrinsic Safe Relay)	P&F
8.		Switch gears, Fuses, Indication lamps, etc for the panel	SIEMENS /ABB
9.		push button or car operating cum control buttons & indicators	As per LIFT Standard supplier's make / SIEMENS will be selected based on asthetic appearance & as per the operational suitability.
10.		Light fittings	Make – M/s BALIGA
11.		Flame proof junction box	Make – M/s BALIGA No. of input: min 3 nos No of output: min 3 nos Gland : stainless steel, double compression gland

12.		Elevator Control Panel (ECP)	RITTAL/President
13.	After sales service	Party shall have authorised service agents in southern india and shall extend the service for a period of 10 years.	

Bid Qualification Criteria for Supply of Hydraulic lift

Bidders who are qualifying/meeting following Technical and Financial capabilities are eligible to participate in the bid for supply of hydraulic lift. Bidder shall furnish all the details with documentary proof and submit the same along with quotation. Bids of the parties which are not meeting the following criteria will not be considered for evaluation and will be rejected without seeking any further clarifications. Bidder shall furnish the details of their resources in factory like manpower, machinery, quality system etc., for department to assess their capability.

S.No	Criteria / Requirement	Reply / Eligibility from M/s....
Technical Qualification Requirements: The bidder should meet the following technical qualifying requirements and shall submit relevant certificates/data to establish his credentials along with the technical bid.		
1.	Bidder should have at least 5 years of experience in fabrication, supply and testing of hydraulic lifts. List of such works shall be enclosed.	
2.	Bidder should have 50 customers (min) to whom hydraulic lift is supplied. Details of customers shall be provided along with bid. Performance certificate from at least three customers shall be provided along with bid.	
3.	The Bidder should be an organization with previous experience in having executed at least one contract worth min 28 lakhs or two contracts of min 21 lakhs each, involving fabrication, supply, erection, and commissioning of hydraulic lifts during last 5 years. Enclose list of works executed with details and PO copy.	
4.	The Bidder shall have previous experience in fabrication, supply erection, and commissioning of hydraulic lifts of capacity of 300kg or more. List of such jobs shall be enclosed.	
5.	The Bidder shall have qualified fitters and welders team.	
Financial Qualification Requirements: The bidder should also meet the following financial qualification requirements:		
6.	The Bidder should have average annual turnover of not less than a value of Rs. 42 lakhs per year during the last three years ending 31st March 2018. Audited annual financial accounts report shall be submitted for the last three years ending 31st March 2018.	
7.	IT return shall be submitted for last 3 years ending 31st March 2018.	

1. Important notes:

- 1.1. In the above technical qualification, bidder shall clearly indicate the list of sub vendors in case of outsourcing if any. The same shall be evaluated and approved by purchaser.
- 1.2. Bidder shall furnish all the above details fully and explicitly. The Bidder shall enclose the documents in support of the details provided in the bidder qualification.
- 1.3. Please note that the "BID" without above mentioned documents/information in support of the eligibility criteria will be summarily rejected.
- 1.4. No further clarifications will be sought in this regard.

2. Bid Selection Procedure and Process of Pre-Qualification

Step-1: Technical Bids will be opened and scrutinized for meeting all technical specification and supply conditions

Step-2: Short listing based on documents submitted, satisfying all the eligibility criteria given above by the Bidder or individual along with their Bid / application. (Non-submission of any document as given in above list within stipulated time leads to rejection of Bid)

Step- 3: Subsequently Bidder's competency, their technical achievements and financial status will be evaluated suitable for this project.

Step- 4: If required, visit will be made to their factory of the Bidder by technical team (ISRO or third party) for accessing the capability of manufacturer.

Step- 5: Visit to sites, wherever required by technical team (ISRO or Third party)

ISRO-SHAR reserves right to verify the information/data furnished by Bidder. If the same is found as fault or with any deviation the bid will be rejected. Only those Bidders who are found suitable & meeting all above qualification Criteria/requirements will be finally qualified for opening the Price Bids for evaluation.

COMPLIANCE STATEMENT FORM

S. No.	Description	Bidder's compliance Yes/No
General terms		
1.	Confirm that the entire scope of work as given in the tender specification is considered for quoting the price. All deviations shall be brought out separately. In the absence of deviations list, it will be presumed that all the specification given is adhered to.	
2.	Design, fabrication, transportation, erection and commissioning of hydraulic lift as per the details given in the tender document.	
3.	PBG: Party shall submit performance bank guarantee for 10% of order value.	
4.	LD: If the supplies are not made by the end of delivery period, liquidated damage will be levied @ 0.5 % per week or part thereof subject to a maximum of 10% of value of undelivered stores	
5.	Party shall submit security deposit for 10% of the total order value.	
6.	Offer shall be valid for six months from the due date for submission of the Bid.	
7.	In case Bid does not fully comply with the requirement of Proposal document and the bidder stipulates deviations to the clauses of the proposal, which are unacceptable to the Department, the Bid will be rejected.	
8.	The hydraulic lift sub systems shall be supplied within Four months from the date of award of purchase order	
9.	Erection and commissioning shall be completed within Two month from the date of all site clearances.	
10.	All bought out items shall be as per tender document only.	
11.	The hydraulic lift shall be guaranteed against any manufacturing defects for a period of 12 months from the date of commissioning. If any defects are noticed during the above period, the same shall be rectified/replaced at free of cost. Party shall check performance and carry out preventive maintenance of lift twice during guarantee period	
Technical Terms:		
1.	Location: Casting Pit	

Tender Document for hydraulic lift

Annexure-2

S. No.	Description	Bidder's compliance Yes/No
2.	Type of lift: Passenger Lift (Hydraulically operated indirect acting lift)	
3.	Corrosive location: Coastal area.	
4.	Capacity of lift: The lift capacity shall be minimum 300 kg.	
5.	Lift shall be located in Hazardous area (Zone-1, Gas group IIA/IIB, T4). Hydraulic power pack shall be located at safe area in finished floor level (FFL), at a distance of about approx. 70m away from lift.	
6.	Standard power pack of reputed make as per preferred vendor list (clause no.7 of tender document) shall be used. Power pack shall have standard items like Pressure relief valves, pressure line filter, return line filter, reservoir, air breather, hydraulic pump, etc.	
7.	Hand pump shall be provided for manual operation of lift (upward movement).	
8.	Permanent SS hydraulic tubes of suitable rating shall be used. Hydraulic tube shall be run from power pack to lift over standard supports. Flexible hoses shall be used for min distance only. Party shall provide standard supports for hydraulic line routing. Size of the tubing shall be worked out based on the power pack location and distance of lift from power pack so that back pressure is minimised.	
9.	Cabin size; 1050mm X 900mm or nearest standard based on the available clear gaps at site. Party shall try to maximize the size of cabin during detailed engineering.	
10.	Lift well size: Max clear gap 1300mm (Width) X 1450mm (Depth)	
11.	Travel of lift: 15.2m(approx.)	
12.	Speed: 0.3 to 0.5 m/sec or as per standard	

Tender Document for hydraulic lift

Annexure-2

S. No.	Description	Bidder's compliance Yes/No
13.	No of landings:3	
14.	<ul style="list-style-type: none"> • Location of landings: • First landing @ 2.515m below FFL • Intermediate landing @ 6.650m below FFL • Last landing @ 17.750m below FFL 	
15.	Landing Call & Car Callbutton: At each landing and also inside cabin	
16.	<p>Type of door: Cabin door - Stainless Steel Manual telescopic/sliding door with vision glass panel.</p> <p>Landing door - Stainless Steel Manual telescopic/sliding door with vision glass panel.</p>	
17.	Material of construction: Stainless Steel 304 for Cabin inside and all entry doors and door frame.	
18.	Cabin interior Finish: Matt finish	
19.	Clear gap between 1 st landing and finished floor level(FFL): 2.29m	
20.	Pit depth below the last landing: 1m approx.(Shall be optimised)	
21.	<p>Fixtures inside car: SS hand rail</p> <p>False ceiling (SS)</p>	
22.	<p>Operating devices: In the Lift Car: call buttons for G (first landing), -1(intermediate landing), -2(last landing), Alarm, light on /off, Emergency Stop), Key operated Selector for Attendant.</p> <p>At the landing: call button for up, down, emergency stop and etc.</p> <p>Minor changes required to ensure safe operation of lift shall be incorporated during detail engineering at no extra cost.</p>	
23.	<p>Lowering of lift in case of failure. Necessary Provision shall be made on power pack for lowering the lift to next level in case of power failure.</p> <p>Also provision for opening the landing door in case of emergency</p>	

Tender Document for hydraulic lift

Annexure-2

S. No.	Description	Bidder's compliance Yes/No
	shall be provided.	
24.	Automatic rescue device (ARD): ARD shall be provided. During power failure provision shall be made to facilitate the lift to reach at next nearest level (down only). UPS and other accessories required for operation of ARD shall be provided.	
25.	Rupture valve mechanism: Rupture valve mechanism shall be provided. Rupture valve shall be capable for stopping the car in down ward movement and maintaining it stationary. Rupture valve shall be tripped when speed reaches rated speed downward plus 0.3 m/s.	
26.	Buffer (A resilient stop at the end of travel and comprising by means of braking using spring): Buffer shall be provided	
27.	Factor of safety (F.O.S): Suspension rope for car: 12 (min) Flexible hose : 8 (min) Jack /cylinder: 1.7(min)	
28.	Suspension rope nominal dia: Rope nominal dia shall be finalized considering the F.O.S of rope 12(min)	
29.	Protection against overheating of the hydraulic fluid: Temp detecting device shall be provided on power pack. The device shall trip the power pack.	
30.	Non return valve: A non-return valve shall be provided. It shall be installed in the circuit.	
31.	Down direction valves: Down direction valve shall be provided. It is an electrically controlled valve in a hydraulic circuit for controlling the descent of the car.	
32.	Shut-off valve: Shut-off valve shall be provided. It shall be installed in the circuit which connects the cylinder to	

S. No.	Description	Bidder's compliance Yes/No
	the non-return valve and down direction valve	
33.	<p>Electrical anti creep system: Electrical anti creep system shall be provided which satisfies the following condition:</p> <ul style="list-style-type: none"> • The machine shall be energized in the up direction independent of the position of the door, when car in a zone which extends from maximum 0.12m below the landing level to the lower end of the unlocking zone <p>The car shall be dispatched automatically to the lowest landing within 15 min after the last normal journey (when doors are closed)</p>	
34.	Minimum number of rope: 2 per jack.	
35.	Overload indicator: Car shall be provided with overload indicator and shall be interlocked with operation of lift. This indicator shall be designed to operate through intrinsic safe relay.	
36.	Display: Fluorescent instructions including Do's and Don'ts shall be indicated on stainless steel plate. The instructions shall include basic instructions and response to various conditions likely to be encountered in the lift such as (but not limited to): -Action to be taken in case of getting stuck-up in the lift.	
37.	Power supply: 415V, 3-Ph, 4-W, 50Hz	
38.	<p>Electrical fittings inside lift: All the electrical fittings like light etc shall be suitable to use in Hazardous area.</p> <ol style="list-style-type: none"> 1. All light fittings shall be mounted on the car top and hooter shall be positioned at safe area, 65m away from the lift. 2. FLP Junction box to be provided for routing the power cable. <p>Junction box location shall be finalised during detailed engineering</p>	
39.	Call point /Push button station: All Service Call point/push button stations (including the sl. no. 23, 44 & 45 of this table) shall be provided with Intrinsic Safe operation relays. The aesthetic point to be considered while selecting this Call point / push button station (both inside and in each landing).	

S. No.	Description	Bidder's compliance Yes/No
	The same to be finalized during detailed engineering. The supplier can use standard reputed make and at the same time it is to be operated through intrinsic safe relay/circuit.	
40.	Protection devices/ control cards: All protection devices / control cards shall be provided inside electrical panel itself.	
41.	Digital input/ digital output relay: All the field signals are to be routed through digital input or digital output Intrinsic Safe relays.	
42.	<p>Operating button details: <u>Landing Call Panel:</u> Call button for up, down, emergency stop and etc</p> <p><u>Car Call Panel:</u> Buttons for G (first landing),-1(intermediate landing),-2(last landing), light, alarm and etc.</p> <p><u>Electrical Panel:</u> Buttons for Maintenance.</p> <p>Minor changes required to ensure safe operation of lift shall be incorporated during detail engineering at no extra cost</p>	
43.	<p>Limit switches & Indication lamps.: Level switch – 2 (1 Main + 1 Redundant)</p> <p>Door zone -2 (1 Main + 1 Redundant)</p> <p>Top limit switch – 2 (1 Main + 1 Redundant)</p> <p>Bottom limit switch – 2 (1 Main + 1 Redundant)</p> <p>Indication lamp (cluster LED type) / indicator (LCD Display)</p> <p>Intrinsically safe self-illuminated P.B if it is selected for this application</p>	
44.	Staircase: Party shall provide structural staircase from last landing of lift to pit bottom (approx 1m). Staircase shall be fabricated after completion of erection of lift at site	
45.	Cage around lift: At last landing, structural cage all around lift shall be provided (side walls are not available at pit bottom). Swing doors shall be provided to access the lift for carrying out maintenance works. Cage shall be fabricated at site after erection of lift. Cage shall be	

Tender Document for hydraulic lift

Annexure-2

S. No.	Description	Bidder's compliance Yes/No
	painted as per specification given in this document	
46.	<i>Electrical</i> requirement: Shall be as per clause no.6 of this tender document.	
47.	Standards: Lift shall comply with IS 14665 and EN 81.2/ASME 17.1. If the party complying with any other equivalent standards, the same shall be indicated clearly.	
48.	QAP, Hydraulic circuit diagram, Electrical circuit diagram, general arrangement drawing etc: Shall be submitted by the bidder as per this tender document.	
49.	After sales service: Party shall have authorised service agents in southern india and shall extend the service for a period of 10 years. Details of service agents shall be submitted along with bid document.	
50.	Tests required to qualify the hydraulic lift: Tests shall be carried out as per tender document, to qualify the hydraulic lift	
51.	Elevator Control Panel (ECP): Elevator control panel shall be supplied and commissioned as per tender document.	
52.	Makes of bought out components: For standard bought out components whose details are furnished in the tender in the form of preferred vendor list (clause no.7 of tender), the bidder shall adhere to the respective makes only. If Party proposes any other make then party shall bring out relative merits w.r.t each of the specification. In such case, department has right to accept or reject.	

Deviation Table

S. No.	Tender Specification	Deviations	Reason for Deviations

Price Bid Schedule for hydraulic lift as per Technical Specifications and terms & conditions given in Tender

Tender No. & Date:

Bidder's Quotation No. & Date:

Note:

1. Bidder shall also submit the un-priced Format along with Techno – Commercial Bid by mentioning “quoted” against each item. The same shall be uploaded along with technical specification.
2. The price bid should be submitted only as per the given below format. No row shall be left blank. Indicate "NA" in case the item is “not applicable”.
3. Price shall be submitted on-line covering all the below components. Any un-filled price bid is likely to get rejected.

Bidder shall submit following un-priced format:

S. No.	Description	Quantity	Party's Confirmation
1.	Basic Price for supply of hydraulic lift FOR Sriharikota as per specifications provided in the tender document.	01 Nos.	
2.	Basic Price for erection and commissioning of hydraulic lift at Sriharikota as per specifications provided in the tender document.	01 Nos.	
3.	GST for S.No.: 1.	% of value	
4.	GST for S.No.: 2.	% of value	
5.	Total Value including taxes (for individual items)		

Date:

Signature & Office Seal of the bidder



Satish Dhawan Space Center SHAR

Welcome, Materials Master (isro)

31 August 2017,
17:16:08 IST

[MAIN VIEW](#)

[HELP](#)

Preview For STANDARD TERMS AND CONDITIONS

Page Destination: Tender Header **Format Type :** Normal

. :

GOVERNMENT OF INDIA

DEPARTMENT OF SPACE

SATISH DHAWAN SPACE CENTRE

PURCHASE DIVISION

Tele No.08623-225023/225174/225127

Fax No.08623-225170/22-5028

e-Mail ID : hps@shar.gov.in, hasan@shar.gov.in, sselvan@shar.gov.in

STANDARD TERMS & CONDITIONS

1.OFFERS SHALL BE SENT ONLINE ONLY USING STANDARD DIGITAL SIGNATURE CERTIFICATE OF CLASS III WITH ENCRYPTION / DECRYPTION. THE TENDERS AUTHORISED ONLINE ON OR BEFORE THE OPEN AUTHORISATION DATE AND TIME ONLY WILL BE CONSIDERED AS VALID TENDERS EVEN THOUGH THE BIDS ARE SUBMITTED ONLINE.

2.THE TENDERER MUST AUTHORISE BID OPENING WITHIN THE TIME STIPULATED IN THE SCHEDULE BY SDSC SHAR. OTHERWISE THE ONLINE BID SUBMITTED WILL NOT BE CONSIDERED FOR EVALUATION. PHYSICAL COPY WILL NOT BE CONSIDERED EVEN THOUGH IT IS RECEIVED BEFORE THE BID SUBMISSION DATE.

In case of two-part tenders, parties shall submit their offers as follows:-

1) Part-I – Techno-commercial Bid

(No price details shall be mentioned in this bid and shall not upload the details of price along with the techno-commercial bid)

2) Part-II – Price Bid

In view of Two Part Tender, the Offers submitted contrary to above instructions will be summarily rejected.

3.In case, the tenderer is not interested to participate in the tender, the tenderer shall submit regret letter giving reasons, failing which future enquiries will not be sent.

4.**Offer Validity:** The validity of the offers / tenders should be 90 days (in case of single part tender) and 120 days (in case two part tender) from the date of opening of the tenders. Tenders with offer validity less than the period mentioned above, will not be considered for evaluation.

5.**GST** - GST and/or other duties/levies legally leviable and intended to be claimed should be distinctly shown separately in the tender. GST details are given below

GSTIN: 37AAAGS1366J1Z1

LEGAL NAME : SATISH DHAWAN SPACE CENTRE SHAR

VALIDITY FROM:29/08/2017

TYPE OF REGISTRATION:REGULAR

6.**Customs Duty** - SDSC-SHAR is eligible for 100% Customs Duty exemption as per Notification No. 050/2017 539 (b) Dt: 30.06.2017. This may be taken into account while quoting for import items, if any.

In case tenderers offering items considering customs duty exemption, they should also indicate the bill of materials and price, separately, with Customs Duty component and terms and conditions thereto.

8.**Advance Payment** - Wherever advance payment is requested, Bank Guarantee from any Nationalized Bank/Scheduled Bank should be furnished. In case of advance payments, if the party is not supplying the material within the delivery schedule, interest will be levied as per the Prime Lending Rate of RBI plus 2% penal interest.

Interest will be loaded for advance payments/stage payments as per the prime lending rate of RBI and will be added to the landed cost for comparison purpose. In case of different milestone payments submitted by the parties, a standard and transparent methodology like NPV will be adopted for evaluating the offers.

9.**Liquidated Damages** - In all cases, delivery schedule indicated in the Purchase Order/Contract is the essence of the contract and if the party fails to deliver the material within the delivery schedule, Liquidated Damages will be levied @ 0.5% per week or part thereof subject to a maximum of 10% of total order value.

10.**Performance Bank Guarantee** - Performance Bank Guarantee for 10% of the order value should be furnished in the form of Bank Guarantee from nationalized/scheduled bank or by Demand Draft valid till warranty period plus sixty days as claim period.

11. **Security Deposit** – Security Deposit for 10% of the order value is mandatory, if the ordered value is Rs.5.00 lakhs and above. Party shall furnish the Security Deposit in the form of Bank Guarantee from nationalized/scheduled bank or by Demand Draft valid till completion of the contract period plus sixty days towards claim period for faithful execution of the contract.

12. **BANK GUARANTEE FOR FIM:** Supplier has to submit Bank guarantee for equal value of Free Issue of Materials (FIM) issued by the Department from Nationalised / Scheduled Bank valid till receipt and acceptance of supply and satisfactory accounting of FIM plus sixty days as claim period.

13. The delivery period mentioned in the tender enquiry, IF ANY, is with the stipulation that no credit will be given for earlier deliveries and offers with delivery beyond the period will be treated as unresponsive.

14. The Department will have the option to consider more than one source of supply and final orders will be given accordingly.

15. The bidders should note that conditional discounts would not have edge in the evaluation process of tenders.

16. Non-acceptance of any conditions wherever called for related to Guarantee/ Warranty, Performance Bank Guarantee, Security Deposit, Liquidated damages are liable for disqualification.

17. Wherever installation/ commissioning involved, the guarantee/warranty period shall reckon only from the date of installation and commissioning.

18. Purchase/Price Preference will be extended to the MSMEs under the Public Procurement Policy for MSMEs formulated under the Micro, Small and Medium Enterprises Development Act, 2006 and instructions issued by Government of India from time to time. Vendors who would like to avail the benefit of MSME should clearly mention the same and submit all the documentary evidences to substantiate their claim along with tender itself.

19. The drawings, specifications, end use etc., given by the Centre/Unit along with the tender enquiry are confidential and shall not be disclosed to any third party.

20. **SPECIAL CONDITIONS FOR SUBMITTING QUOTATIONS IN FOREIGN CURRENCY BY THE INDIAN AGENTS**

The Tenderer should submit the following documents/information while quoting:-

a) Foreign Principal's proforma invoice/quote indicating the commission payable to the Indian Agent and nature of after sales service to be rendered by the Indian Agent.

b) Copy of Agency agreement with the Foreign Principal and the Indian Agent, precise relationship between them and their mutual interest in the business.

c) Registration and item empanelment of the Indian Agent.

d) Agency Commission will be paid only Indian Currency.

e) Compliance of the tax laws by the Indian Agent.

21. **High Sea Sales**- Against High Sea Sale transactions:

a. Offers shall be on all inclusive basis including delivery upto Sriharikota at the risk and cost of the supplier. Customs Clearance is the responsibility of the supplier and at his cost and risk.

b. 100% payment will be made within 30 days after receipt and acceptance of the items at our site.

c. GST as applicable

d. Customs Duty Exemption Certificate and other relevant documents required for Customs clearance will be provided.

e. High Sea Sales Agreement furnished by the supplier in accordance with the terms and conditions of our purchase order will be signed and issued by SDSC-SHAR.

22. The following information/ documents are to be submitted wherever applicable.

1. Product Literature

2. Core banking account number of SBI, RTGS Details

3. PAN No. in quotation and invoices

4. GST Registration details.

5. In case of MSME, registration details / documents from Competent Authority.

23. **EXCLUSION OF TENDERS**

The following tenders shall be summarily rejected from the procurement process

a. Tenders received from vendors who have not qualified in terms of their registration.

b. Tenders received against publishing of a limited tender in the CPP portal.

c. Tenders of vendors who have been removed from the vendor list or banned/debarred from having business dealings.

d. Unsolicited tenders from vendors.

e. The tenders which materially depart from the requirements specified in the tender document or which contain false information.

f. The tenders which are not accompanied by the prescribed Earnest Money Deposit.

g. The tenders of vendors who have not agreed to furnish Security Deposit, Performance Bank Guarantee and Liquidated Damages.

h. The validity of the tenders is shorter than the period specified in the tender enquiry.

i. The tenders received from vendors or their agents or anyone acting on their behalf, who have promised or given to any official of the Centre/Unit/Department, a gratification in any form, or anything of value, so as to unduly influence the procurement process.

j. The tenders received from vendors, who, in the opinion of the Centre/Unit, have a conflict of interest materially affecting fair competition.

k.The tenders received from Indian agents on behalf of their foreign Principals/OEMs (in cases where the Principals/OEMs also submit their tenders simultaneously for the same item/product in the same tender).

l.In case two or more tenders are received from an Indian agent on behalf of more than one foreign Principal/OEM, in the same tender for the same item/product.

m.If a firm quotes 'NIL' charges / consideration, the bid shall be treated as un-responsive and will not be considered.