

1. A beam is having a triangular cross section with its neutral axis ~~XX~~. The section modulus about ~~XX~~ is given by

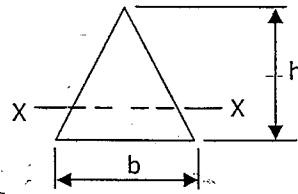

- (a) $bh^2/6$ (b) $bh^2/36$ (c) $bh^2/24$ (d) $hb^2/36$

2. A rectangular column is subjected to an eccentric load P at distance 'e' from centroidal Axis. The stress diagram at Cross-section will be

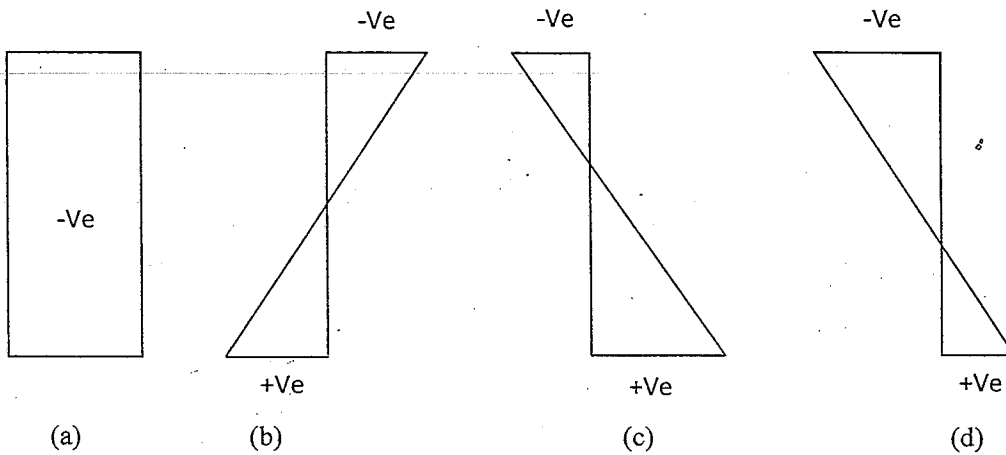

3. Two shafts A & B are made of same material. The radius of the shaft A is half that of shaft B. The power transmitted by the shaft A will be ---- that of shaft B.

- (a) 1/8 times (b) 8 times (c) sixteen times (d) Twice

4. Four linear elastic springs are connected to mass 'M' as shown in Figure. The natural frequency of the system is

- (a) $(\sqrt{4k/3m}) / (2\pi)$
 (b) $(\sqrt{4k/m}) / (2\pi)$
 (c) $(\sqrt{k/4m}) / (2\pi)$
 (d) $(\sqrt{3k/4m}) / (2\pi)$

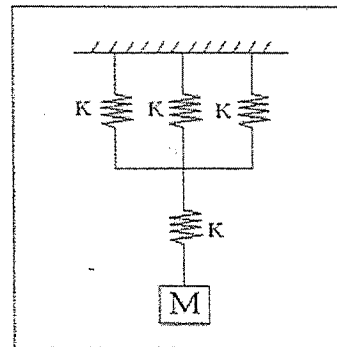

5. Which bearing offers lowest friction

- (a) hydrostatic Bearing (b) Roller Bearing
(c) Aero- static Bearing (d) Hydrodynamic Bearing

6. A circular disk of radius R rolls without slipping at a velocity V . The magnitude of the velocity at point P shown in the figure is

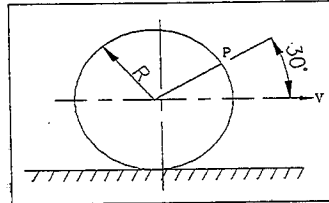

- (a) $\sqrt{3} V$ (b) $\sqrt{3}/2 V$ (c) $V/2$ (d) $\sqrt{2} V$

7. In the viscous damped vibration, the logarithmic decrement value over five cycles is found to be 8.11. What is viscous damping factor of vibratory system?

- (a) 20% (b) 25% (c) 30% (d) 15%

8. An elevator weighing 1000Kg attains an upward velocity of 4m/sec in two seconds with uniform acceleration. The tension (in N) in supporting cable will be ($g=9.8\text{m/sec}^2$)

- (a) 1204 N (b) 9800 (c) 2000N (d) 11800N

9. A block weighting 981 N is resting on Horizontal surface. The co-efficient of friction between the block and horizontal surface is $\mu=0.2$. A vertical cable attached to block provides partial support as shown. A man can pull horizontally with a force of 100N. What will be the tension (T) (in N) in the cable if the man is just able to move the block to the right?

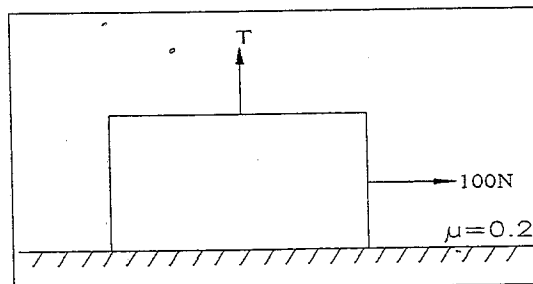

- (a) 176.2 (b) 196.0 (c) 481.0 (d) 981.0

10. A vehicle suspension system consists of a leaf spring and a damper. The stiffness of the leaf spring is 3.6 KN/m and damping constant of the damper is 400 Ns/m. If the mass is 50Kg, then the damping factor and damped natural frequency respectively are
- (a) 0.471 and 1.19 Hz (b) 0.471 and 7.48 Hz
 (c) 0.666 and 1.35 Hz (d) 0.666 and 8.50 Hz
11. A rotating disc of 1m diameter has two eccentric masses of 0.5 kg each at radii of 50mm and 60mm at angular position of 0° and 150° , respectively. A balancing mass of 0.1Kg is to be used to balance the rotor. What is the radial position of balancing mass?
- (a) 50mm (b) 120mm (c) 150mm (d) 280mm
12. Two mating spur gears have 40 & 120 teeth respectively. The pinion rotates at 1200 rpm and transmit torque of 20Nm. The torque transmitted by the gear is
- (a) 6.6Nm (b) 20Nm (c) 40 Nm (d) 60 Nm
13. The figure below shows a steel rod of 25 mm^2 cross sectional area. It is loaded at four points, K, L, M, N. Assume $E \text{ steel} = 200 \text{ GPa}$. The total change in length of the rod due to loading is

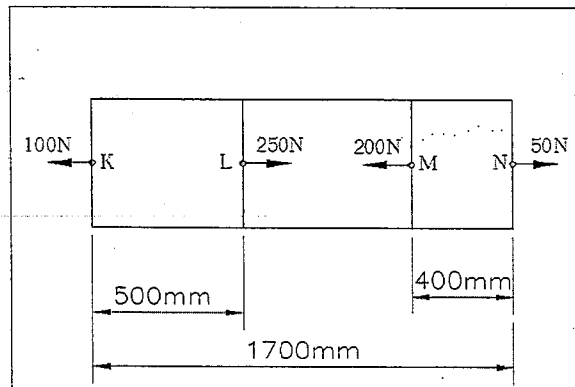

- (a) $1 \mu\text{m}$ (b) $-10 \mu\text{m}$ (c) $10 \mu\text{m}$ (d) $-20 \mu\text{m}$

14. Planetary gear is in contact with the fixed gear as shown in the figure. The number of rotations made by the planetary gear for one rotation of the arm is

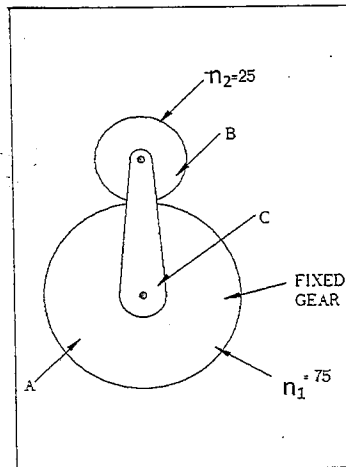

- (a) 3 (b) 4 (c) 1 (d) 1/3

15. The Mohr circle reduces to a point when the body is subjected to

- (a) pure shear (b) uniaxial shear only
 (c) equal axial stress on two mutually perpendicular planes and the planes being free of shear
 (d) equal and opposite axial stress on two mutually perpendicular planes and the planes being free of shear

16. Shear stress distribution for a rectangular beam subjected to transverse loading is

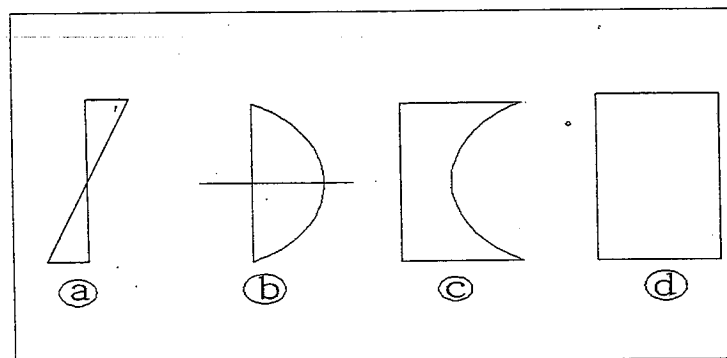

17. Area moment of inertia for the quadrant shown below is

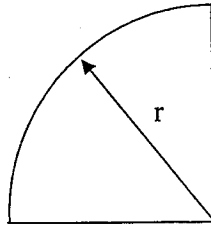

(a) $\pi r^4/2$

(b) $\pi r^4/4$

(c) $\pi r^4/8$

(d) $\pi r^4/16$

18. A column of length 'L' is fixed at bottom end and hinged at the other end. This column is restrained from lateral displacement at $1/3^{\text{rd}}$ height. The buckling load is given by

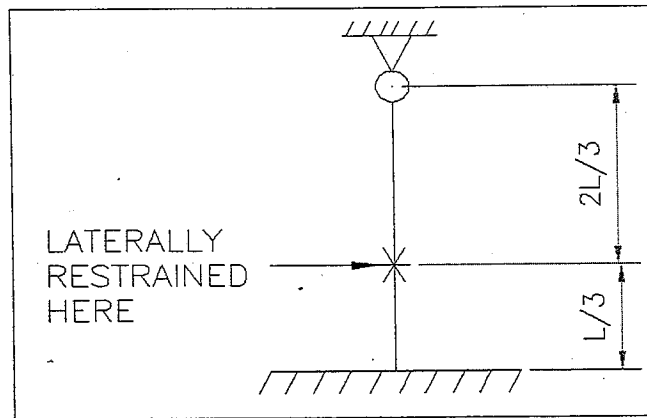

(a) $9\pi^2 EI / (4L^2)$

(b) $4\pi^2 EI / L^2$

(c) $4\pi^2 EI / (9L^2)$

(d) $\pi^2 EI / L^2$

19. A shaft has two heavy rotors mounted on it. The transverse natural frequency considering each rotor separately is 100 hz & 200 hz respectively. The lowest critical speed is

(a) 13000 rpm

(b) 5367 rpm

(c) 6450 rpm

(d) 9343 rpm

20. A mass 'M' is suspended from a ceiling through a string of length 'L'. This mass moves in a circle of horizontal radius 'r' at constant speed such that it is a conical pendulum. The tension in the string will be

(a) $mgL / (2\sqrt{L^2 - r^2})$

(b) $mgL / \sqrt{L^2}$

(c) $mgL / \sqrt{r^2}$

(d) $mgL / (\sqrt{L^2 - r^2})$

21. The stress in the rod AB in the pin jointed truss ABCD is

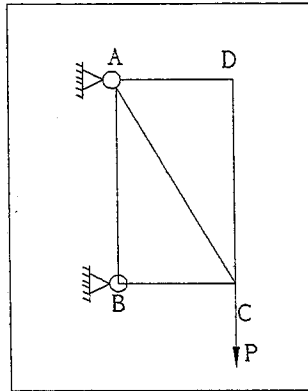

- (a) $2P/\pi d^2$ (b) $4P/\pi d^2$ (c) 0 (d) $P/2\pi d^2$

22. The number of degrees of freedom for the following mechanism is

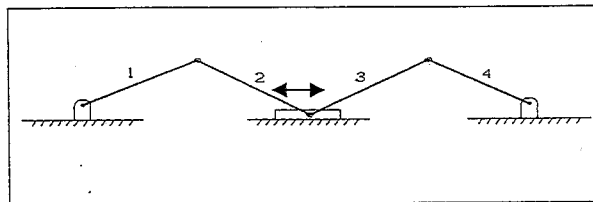

- (a) 0 (b) 1 (c) 2 (d) 4

23. A plate is held by a chain AB through hinge joints. The plate is pulled with a force T as shown in figure. The tension in the chain is given by

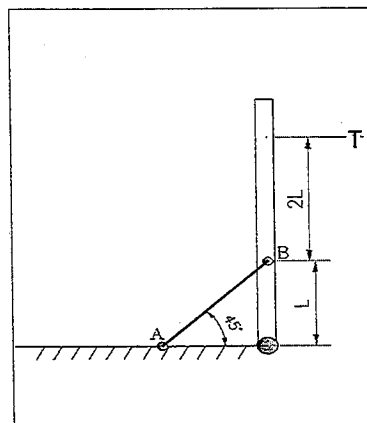

- (a) $(\sqrt{3}/2) T$ (b) $(\sqrt{2}/3) T$ (c) $T/2$ (d) $3\sqrt{2} T$

24. In a turn buckle joint, both mating rods will have

- (a) Right hand threads (b) Left hand threads
(c) Right hand and left hand threads (d) Multiple threads

25. In a flat belt drive, the belt can be subjected to a maximum tension (T) and centrifugal tension (T_c). The condition of transmission of maximum power is given by

- (a) $T = T_c$ (b) $T = 2T_c$ (c) $T = 3T_c$ (d) $T = \sqrt{3} T_c$

26. The diameter of a soap bubble which has an inside pressure of 2.5 N/m^2 over the atmospheric pressure and a surface tension of 0.0125 N/m is

- (a) 40 mm (b) 4 mm (c) 16 mm (d) 60 mm

27. Find the loss of head due to friction in a smooth pipe of rectangular cross section of $1\text{m} \times 0.5\text{m}$ and 10m long. Velocity of flow is 10 m/s and the friction coefficient is 0.01962 .

- (a) 4 m (b) 6 m (c) 8 m (d) 10 m

28. When a supersonic flow is admitted into a convergent, the flow will

- (a) Accelerate (b) Decelerate (c) No change (d) None of the above

29. Which configuration measures the stagnation pressure?

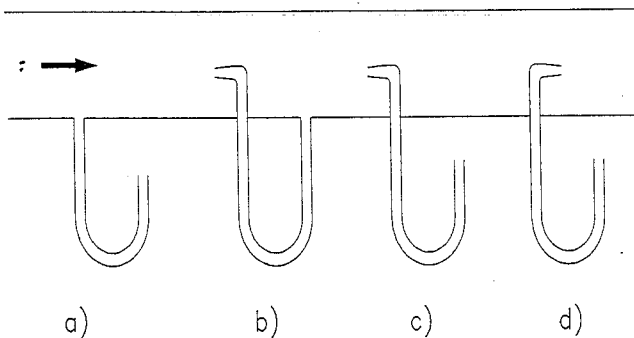

30. The maximum lift in a centrifugal pump would be close to 'X' if the pump is handling cold water (25°C) from an open tank at sea level with no friction and turbulence losses, where 'X' is equal to
- (a) 10 m (b) 1.03 m (c) 100 m (d) 30 m
31. Both pressure and velocity of steam drops in the moving blades of
- (a) Impulse turbine (b) Velocity compounded impulse turbine
- (c) Reaction turbine (d) Pressure compounded impulse turbine
32. A model of a golf ball is to be studied to determine the effects of the dimples. A sphere 10 times larger in diameter than an actual golf ball is used in the wind tunnel study. What speed should be selected for the model to simulate a prototype speed of 50 m/s?
- (a) 0.2m/s (b) 5m/s (c) 50m/s (d) 10m/s
33. The sound of explosion on a ship located 10km away from the beach was heard 28.6 seconds after the explosion was seen. Estimate the temperature of air at that time.
- (a) 31°C (b) 31 K (c) 26.2°C (d) 288.5K
34. A spherical balloon is filled with helium at sea level. Helium and balloon material together weigh 500 N. If the net upward lift force on the balloon is also 500 N, what is the diameter of the balloon?
- (a) 5.42m (b) 6.78m (c) 3.43m (d) 2.34m
35. Air at 20°C and 10^5Pa enters the bottom of an 85° conical flow meter duct at a mass flow rate of 0.3 kg/s, as shown in the figure. It supports the centered conical body by steady annular flow around the cone and exits at the same velocity as it enters. Estimate the weight of the body in Newtons

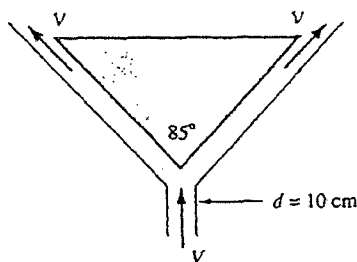

- (a) 2.5N (b) 1N (c) 3.5N (d) 4N

36. A jet of water issues from a nozzle with a velocity 20 m/s on a flat plate moving away from it at 10 m/s. The cross-sectional area of the jet is 0.01 m^2 and the density of water = 1000 kg/m^3 . The force developed on the plate is

- (a) 1000 N (b) 100 N (c) 10 N (d) 2000 N

37. The laminar boundary layer thickness varies as

- (a) $1/\sqrt{x}$ (b) $x^{1/7}$ (c) $x^{1/2}$ (d) $x^{6/7}$

38. An increase in pressure of a liquid from 7.5 MPa to 15 MPa results into 0.2 percent decrease in its volume. The coefficient of compressibility of the liquid in m^2/N is

- a) 0.267×10^{-9} b) 2.67×10^{-9} c) 1×10^{-9} d) None of the above.

39. A reservoir of capacity 0.01 m^3 is completely filled with a fluid of coefficient of compressibility $0.75 \times 10^{-9} \text{ m}^2/\text{N}$. The amount of fluid that will spill over (in m^3), if pressure in the reservoir is reduced by $2 \times 10^7 \text{ N/m}^2$ is

- a) 1×10^{-4} b) 1.5×10^{-4} c) 0.15×10^{-4} d) None of the above

40. The extent of pressure produced due to water hammer depends on

- (a) Velocity of flow of fluid in the pipe
 (b) length of the pipe
 (c) time taken to close the valve ; gradual or quick closure of the valve
 (d) All the above

41. Rank of the matrix

$$A = \begin{bmatrix} 1 & 1 & 2 \\ 1 & 2 & 3 \\ 0 & -1 & 1 \end{bmatrix} \text{ is}$$

- (a) 0 (b) 1 (c) 2 (d) 3

42. The value of t for which $A + tB$ is perpendicular to C where $A = i + 2j + 3k$, $B = -i + 2j + k$ and $C = 3i + j$

- (a) 5 (b) 4 (c) 12 (d) 0

43. $\bar{A} \times \bar{B}$ is a vector

- (a) Parallel to \bar{A} , but perpendicular to \bar{B}
 (b) Parallel to \bar{B} , but perpendicular to \bar{A}
 (c) Perpendicular to both \bar{A} & \bar{B}
 (d) Parallel to both \bar{A} & \bar{B}

44. The equation of the plane through the line

$$\frac{x-1}{3} = \frac{y-4}{2} = \frac{z-4}{-2} \quad \text{and parallel to the line}$$

$$\frac{x+1}{2} = \frac{y-1}{-4} = \frac{z+2}{1} \quad \text{is}$$

- (a) $3x + 2y - 2z = 101$ (b) $2x - 4y + z = 98$
 (c) $6x + 7y + 16z = 98$ (d) $6x - 8y - 2z = 101$

45. Let E and F be any two events with $P(E \cup F) = 0.8$, $P(E) = 0.4$ and $P(E/F) = 0.3$. Then $P(F)$ is

- (a) $3/7$ (b) $4/7$ (c) $3/5$ (d) $2/5$

46. The approximate value of $y(0.1)$ from $dy/dx = x^2y - 1$, $y(0) = 1$ is

- (a) 0.900 (b) 1.001 (c) 0.802 (d) 0.994

47. $1 + i$ is equivalent to

- (a) $\sqrt{2}e^{-i\pi/4}$ (b) $\sqrt{2}e^{i\pi/4}$ (c) $2e^{-i\pi/4}$ (d) $2e^{i\pi/4}$

48. In a class of 45 students, the mean mark of 25 girls is 32 and the mean mark of 20 boys is 27.5. What is the class mean?

- (a) 32 (b) 27.5 (c) 29.75 (d) 30

49. If $L\{f(t)\} = F(s)$, then the value of

$L\{e^{-at} f(t)\}$ is

- (a) $F(s-a)$ (b) $F(s+a)$ (c) $F(s)$ (d) $F(e^a s)$

50. The probability that A happens is $1/3$. The odds against happening of A are

- (a) 2 : 1 (b) 3 : 2 (c) 1 : 2 (d) 2 : 3

51. Draft on pattern for casting is provided for

- (a) Shrinkage allowance (b) Identification
(c) Taper to facilitate removal from mould (d) Machining allowance

52. Welding spatter is

- (a) Welding defect (b) Flux (c) Electrode Coating (d) Welding technique

53. Which of the following statements is false about annealing? Annealing is done to

- (a) Harden Steel slightly (b) Relieve Stress
(c) Soften metal (d) Permit further cold working

54. The property of corrosion resistance of chromium Stainless Steel is due to

- (a) Predominant nature of Cr present in stainless steel
(b) The formation of thin film of oxygen & moisture absorbed from the atmosphere
(c) The formation of a thin film of Cr_2O_3 on the surface of steel
(d) The inherent property of Cr to resist corrosion

55. Hot working operation is carried out at

- (a) Re-crystallization temperature (b) Near plastic stage temperature
(c) Below re-crystallization (d) Above re-crystallization

56. The engineering and true strains for a bar which is doubled in length during tension test are

- (a) $e = 1.0, \epsilon = 0.693$ (b) $e = 2, \epsilon = 1$ (c) $e = \frac{1}{2}, \epsilon = \frac{1}{2}$ (d) None of the above

57. The purpose of adding wood flour to the moulding sand is to improve

- (a) Green strength (b) Hot Strength (c) Collapsibility (d) Permeability

58. Stretch forming is a process in which

- (a) All deformations occur in the direction of stretch
 (b) All forces are applied in the direction of stretch
 (c) Advantage is taken of plastic state indicated due to stretch
 (d) No dies are used

59. In which type of welding, a pool of molten metal is used?

- (a) Submerged arc welding (b) Electro slag welding (c) TIG welding (d) MIG welding

60. A mild steel block of width 40mm is being milled using a straight slab cutter 70mm diameter with 30 teeth. If the cutter rotates at 40 rpm, and depth of cut is 2mm, what is the value of maximum uncut chip thickness when the table feed is 20 mm/min?

- (a) 0.00263mm (b) 0.00363mm (c) 0.00463mm (d) 0.00563mm

61. Match the list I with list II and select the correct answer from the codes given in the lists below

List I
 (Measuring instruments)*

- A. Talysurf
 B. Telescopic gauge
 C. Transfer Calipers
 D. Autocollimator

List II
 (Applications)

1. T slots
 2. Flatness
 3. Internal Diameter
 4. Roughness

Codes

	A	B	C	D
a)	1	2	3	4
b)	4	3	1	2
c)	4	3	2	1
d)	3	4	1	2

62. A shaft has a dimension $\Phi 35^{-0.009/-0.025}$, the respective values of fundamental deviation and tolerance are
- (a) $-0.025, 0.008$ (b) $-0.0025, 0.016$ (c) $-0.009, 0.008$ (d) $-0.009, 0.016$
63. When a material sustains steady loads for long periods of time, the material may continue to deform until they may tend to fracture under the same load. This phenomenon is known as
- (a) Creep (b) Fatigue (c) Impact (d) Malleability
64. Which one of the following is a wrong statement?
- (a) In low carbon steels, phosphorus is added to raise its yield point
(b) Lining of open hearth furnace controls impurities in steel
(c) Blast furnace uses coke as fuel
(d) Manganese is added in blast furnace for better fluidity
65. The most popular and standard type for all purpose tool steels is 18:4:1 High Speed Steel (H.S.S.), which contains.
- (a) 18% chromium, 4% tungsten and 1% vanadium
(b) 18% tungsten, 4% vanadium and 1% chromium
(c) 18% tungsten, 4% chromium and 1% vanadium
(d) 18% vanadium, 4% chromium and 1% tungsten
66. Water is boiled at 1×10^5 Pa pressure in a coffee maker equipped with an immersion-type electric heating element. The coffee maker initially contains 1 kg of water. Once boiling started, it is observed that half of the water in the coffee maker evaporated in 18 minutes. If the heat loss from the coffee maker is negligible, the power rating of the heating element is
- (a) 0.90 kW (b) 1.52 kW (c) 1.05 kW (d) 1.24 kW
67. An adiabatic heat exchanger is used to heat cold water at 15°C entering at a rate of 5 kg/s by hot air at 90°C entering also at rate of 5 kg/s. If the exit temperature of hot air is 20°C , the exit temperature of cold water is
- (a) 27°C (b) 32°C (c) 85°C (d) 90°C

68. Logmean area 'A' can be given as

- (a) $\frac{\log A_2 - \log A_1}{A_2 - A_1}$ (b) $\frac{A_2 - A_1}{\log A_2 - \log A_1}$ (c) $\frac{\log A_2 - \log A_1}{\log(A_2 / A_1)}$ (d) None

69. Nusselt number is the ratio of

- (a) Convective and Conductive resistances
(b) Conductive and Convective resistances
(c) Wall heat transfer rate to mass heat flow rate
(d) Kinetic viscosity to thermal diffusivity

70. Zeroth law of thermodynamics is not valid for the following

- (a) 50 ml of water at 25°C is mixed with 150 ml of water at 25°C
(b) 500 ml of milk at 15°C is mixed with 100 ml of water at 15°C
(c) 5 kg of wet steam at 100°C is mixed with 50 kg of dry and saturated steam
(d) 10 ml of water at 20°C is mixed with 10 ml of sulphuric acid at 20°C

71. When air expands from initial pressure P_1 and volume V_1 to final volume $5V_1$ following the law $PV^n = C$

- (a) greater the value of n, greater the work obtained
(b) smaller the value of n, smaller the work obtained
(c) for $n=0$, the work obtained is the greatest
(d) for $n=1.4$, the work obtained is the greatest

72. Air is compressed to half the volume at constant pressure, then the change in entropy

- (a) increase (b) decrease (c) does not change (d) not predictable

73. A cycle is shown below on P-V diagram

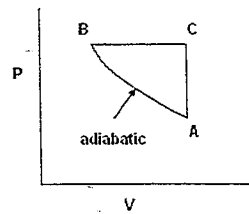

This cycle is represented in T-S diagram by

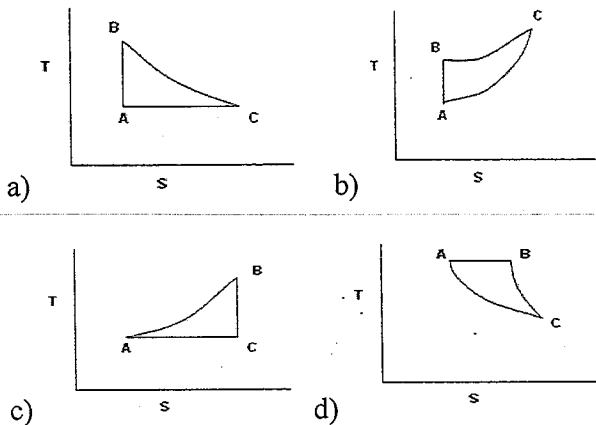

74. If 2 bar of air at 27°C is heated to 177°C at constant volume, the pressure will be

- (a) 6.56 bar (b) 3 bar (c) 9 bar (d) 13.11 bar

75. A friction less heat engine can be 100 percent efficient only if its exhaust temperature is

- (a) equal to its input temperature (b) less than input temperature
 (c) 0 K (d) 0°C

76. An ideal engine absorbs heat at 127°C and rejects at 77°C . The efficiency is

- (a) 13% (b) 39% (c) 50% (d) 40%

77. A Francis turbine running at 200 rpm develops a power of 5000 kW under a head of 25m.
The power output under a head of 100 m will be
- (a) 20,000 kW (b) 30,000 kW (c) 40,000 kW (d) 50,000 kW
78. Steam expands in a turbine from 40 bar, 500 °C to 0.10 bar isentropically. Assuming ideal conditions, given enthalpy drop 1198.8 kJ/kg, nozzle angle 16° and N as 300 rpm. Mean diameter of the wheel, if the turbine were of simple impulse stage, will be
- (a) 3.73 m (b) 4.73 m (c) 5.63 m (d) 4.96 m
79. A refrigerator removes heat from a refrigerated space at -5°C at a rate of 0.35 kJ/s and rejects it to an environment at 20°C. The minimum required power input is
- (a) 30W (b) 33W (c) 56W (d) 124W
80. For the same compression ratio, the thermodynamic cycles in the order of decreasing efficiencies are
- (a) Dual, Diesel, Otto (b) Dual, Otto, Diesel
(c) Diesel, Dual, Otto (d) Otto, Dual, Diesel