

भारत सरकार
अंतरिक्ष विभाग
सतीश धवन अंतरिक्ष केंद्र शार
श्रीहरिकोटा रेंज डा.घ. 524 124
श्री पोष्टि श्रीरामुलु नेल्लूर जिला, आं.प्र., भारत
दूरभाष : +91-8623 245060 (6 जं)
फैक्स : +91-8623 222099



Government of India
Department of Space
Satish Dhawan Space Centre SHAR
Shriharikota Range P.O. 524 124
SPSR Nellore Dist., AP., India
Telephone : +91-8623 245060 (6 Lines)
Fax : +91-8623 222099

निविदा सूचना सं. TENDER NOTICE NO. SDSC SHAR/HPS/PT/RO-VALF/51/2026-27

भारत के राष्ट्रपति की ओर से प्रधान क्रय एवं भंडार, सतीश धवन अंतरिक्ष केंद्र श्रीहरिकोटा निम्नलिखित वस्तुओं के लिए ऑनलाइन निविदाएं आमंत्रित करते हैं/On behalf of President of India, Head Purchase and Stores, SDSC SHAR, SRIHARIKOTA invites on line quotations for the following: -

क्र.सं. SI No	संदर्भ सं. Ref. No.	विवरण Description	मात्रा Qty.
01	SDSC SHAR /VALF PURCHASE /VALF/ 2026000561 Fabrication, Supply, Installation and Commissioning of Modular Executive Consoles, executive chairs, racks for SSLV Launch Complex (SLC), Kulasekarapatnam [Public Tender - Two Part]	Design, Fabrication, Supply, Erection and Commissioning of Flame Proof Double Girder based LINAC Handling System (5t - SWL) and Film Positioning System (50 Kg -SWL) for NDT facility, SLC Project,	As mentioned in the tender

निविदा दस्तावेजों को डाउनलोड करने की अंतिम तिथि Last Date for downloading of tender documents : 13.07.2026 at 16:00 hrs.
ऑनलाइन निविदा जमा करने की अंतिम तिथि Due Date for submission of bids online : 13.07.2026 at 16:30 hrs.
निविदाएं खोलने की नियत तिथि Due Date for opening of tenders : 14.07.2026 at 11:00 hrs.

निविदाकार के लिए निर्देश Instructions to Tenderers:

निविदाएं ईजीपीएस के माध्यम से ही भेजी जाएं तथा कोई निविदा शुल्क लागू नहीं होगा।
Bids shall be submitted on line through EGPS only and No tender fee shall be applicable.

- कार्य के सम्पूर्ण विवरण/जानकारी तथा नियम व शर्तों इत्यादि के लिए संलग्न अनुलग्नक को देखें। / For full details/scope of work and terms and conditions etc., please see the enclosed annexures.
- इच्छुक निविदाकार इसरो की ई-खरीद वेबसाइट इसरो न्यू ई-प्रोकुरमेंट www.eproc.isro.gov.in से ई-निविदा डाउनलोड और अपनी निविदा ई-खरीद पोर्टल पर ऑनलाइन जमा कर सकते हैं। डाक / वाहक / स्वयं द्वारा प्राप्त निविदाओं पर विचार नहीं किया जाएगा। / Interested tenderers can download the e-tender from ISRO e-procurement website ISRO NEW E-PROCUREMENT www.eproc.isro.gov.in and submit the offer on line in the e-procurement portal. Offers sent physically by post/courier/in person will not be considered.
- निविदा दस्तावेज इसरो की वेबसाइट www.isro.gov.in इसरो न्यू ई-प्रोकुरमेंट वेबसाइट www.eproc.isro.gov.in तथा सतीश धवन अंतरिक्ष केंद्र शार की वेबसाइट www.shar.gov.in पर भी उपलब्ध हैं। इन्हें केवल ई-खरीद पोर्टल से डाउनलोड और निविदा ऑनलाइन जमा कर सकते हैं। / Tender documents are also available on ISRO website www.isro.gov.in ISRO New e-procurement website www.eproc.vssc.gov.in and SDSC SHAR, Sriharikota website www.shar.gov.in. The same can be down loaded and offer submitted on line in the new e-procurement portal only.
- निर्धारित तिथि/समय के पश्चात प्राप्त बोलियों पर विचार नहीं किया जाएगा। / Quotations received after the due date/time will not be considered.
- प्रधान क्रय एवं भंडार, सतीश धवन अंतरिक्ष केंद्र श्रीहरिकोटा के पास किसी भी या सभी निविदाओं को स्वीकार / अस्वीकार करने का अधिकार है। / Head, Purchase and Stores, SDSC-SHAR, Sriharikota reserves the right to accept or reject any/or all the quotations.
- GeM ARPTS Report ID: GEM/GARPTS/08052026/XX7GYPH4CY1D

दिनांक DT: 12.06.2026

प्रधान क्रय एवं भंडार
HEAD PURCHASE AND STORES

**GOVERNMENT OF INDIA
DEPARTMENT OF SPACE
SATISH DHAWAN SPACE CENTRE SHAR SRIHARIKOTA (SDSC SHAR)
TIRUPATI**

**Tender for Fabrication, Supply, Installation and Commissioning of
Modular Executive Consoles, executive chairs, racks for SSLV Launch
Complex (SLC), Kulasekarapatnam**

Bids to be submitted online

Tender No.: SDSC SHAR/VALF PURCHASE/SH202600056101 dated 12-06-2026

A. Tender Details

Tender No : **SDSC SHAR/VALF PURCHASE/SH202600056101**

Tender Date : **12-06-2026**

Tender Classification: **GOODS**

Purchase Entity : **VALF PURCHASE**

Centre : **SATISH DHAWAN SPACE CENTRE SHAR SRIHARIKOTA
(SDSC SHAR)**

**Fabrication, Supply, Installation and Commissioning of Modular Executive
Consoles, executive chairs, racks for SSLV Launch Complex (SLC),
Kulasekarapatnam**

GEM/GARPTS/02042026/OVNX1118KZD6

As per tender documents

A.1 Tender Schedule

Bid Submission Start Date : **12-06-2026 17:30**

Bid Clarification Due Date : **19-06-2026 10:00**

Bid Submission Due Date : **13-07-2026 16:30**

Bid Opening Date : **14-07-2026 10:00**

Price Bid Opening Date : **14-08-2026 14:30**

B. Tender Attachments

Technical Write-up/Drawings

Document : RFP Document for supply of Executive Consoles, Executive chairs, Racks and KVMs

Instructions To Vendors

2. INSTRUCTIONS TO TWO PART TENDER

1. We are proposing to invite Tenders in Two Parts viz., Part-I Techno and Commercial & Part-II Price. All Tenderers are requested to follow carefully the following instructions before preparing their offer.

PART- I- TECHNO COMMERCIAL BID:

(1) This part should contain detailed Specifications of the items quoted by you along with Technical Literature and Leaflets if any.

(2) All the Commercial terms and Conditions applicable also should be indicated separately under separate heads.

(3) The Commercial terms such as delivery terms, delivery period, payment terms, warranty, validity of the offer, Installation & Commissioning, Duties and Taxes etc shall come into this.

(4) Either Technical Specifications or Terms & Conditions as above should be very clearly reflected items wise with reference to the items called for in the tender.

(5) Please note that Prices should not be indicated in this part.

(6) Any deviations from the Technical Specifications and Commercial Terms shall be indicated separately.

PART II-PRICE BID:

(1) The prices applicable for the items, item wise in response to the tender shall come into this part.

(2) Tender shall indicate very clearly item wise prices with reference to their Technical Offer.

Note: 1. PLEASE NOTE THAT THE OFFERS SUBMITTED CONTRADICTORY TO ABOVE INSTRUCTIONS WILL BE LIABLE FOR REJECTION. PLEASE ENSURE OFFERS ARE SUBMITTED WITHIN THE DUE DATE.

2. BEING TWO PART TENDER, WE REQUEST YOU NOT TO DISCLOSE / INDICATE ANY OF THE PRICE VALUE WHILE SEEKING / PROVIDING CLARIFICATION. YOU SHOULD INDICATE ONLY IN PERCENTAGE. IN CASE IF YOU DISCLOSE ANY OF THE PRICE AMOUNT YOUR OFFER WILL BE REJECTED.

3. STANDARD TERMS & CONDITIONS

1. 1. OUR GST NUMBER: 37HYDF00385A1DZ- SDSC SHAR SRIHARIKOTA

2. Email for communication: psovalf(at)shar.gov.in

3. Instruction to Indigenous Suppliers:

A) Payment Terms shall be as specified in RFP. If not specifically mentioned Our Normal payment term is 100 percent within 30 days after receipt and acceptance of the item at our site. Please confirm acceptance in your quotation.

B) Purchase - Price preference to MSEs

Purchase - Price preference will be applicable to the product reservation admissible to the Micro and Small Enterprises. Purchase - Price Preference shall be extended to the MSEs under the Public Procurement Policy for MSEs formulated under the Micro, Small and Medium Enterprises Development Act, 2006. The participating MSEs in a tender, quoting price within the band of L-1 plus 15 percent may also be allowed to supply a portion of the requirement by bringing down their price to the L-1 price, in a situation where L-1 price is from someone other than an MSE. Such MSEs may be allowed to supply up to 25 percent of the total tendered value. In case of more than one such eligible MSE, the supply will be shared equally.

Micro and Small Enterprises which have technical capability to deliver the goods and Services as per prescribed technical and quality specifications and may not be able to meet the qualification criterion relating to prior experience minus prior turnover may be relaxed as per guidelines issued by Ministry of MSMEs and as amended from time to time.

Interested vendors shall specifically claim the benefit with supporting documents.

C) Purchase - Price preference to Make-in-India Products:

Preference shall be given to Class 1 local supplier as defined in public procurement (Preference to Make in India), Order 2017 as amended from time to time and its subsequent Orders - Notifications issued by concerned Nodal Ministry for specific Goods - Products. The minimum local content to qualify as a Class 1 local supplier is denoted in the bid document 50 percent. If the bidder wants to avail the Purchase preference, the bidder must upload a certificate from the OEM regarding the percentage of the local content and the details of locations at which the local value addition is made along with their bid, failing which no purchase preference shall be granted. In case the bid value is more than Rupees 10 Crore, the declaration relating to percentage of local content shall be certified by the statutory auditor or cost auditor, if the OEM is a company and by a practicing cost accountant or chartered accountant for OEMs other than companies as per the Public Procurement (preference to Make-in-India) order 2017 dated 04.06.2020 and amendments thereof. In case Buyer has selected Purchase preference to Micro and Small Enterprises clause in the bid, the same will get precedence over this clause.

D) Instruction to Foreign Suppliers-(if allowed as per RFP)

a) Payment Terms shall be as specified in RFP. If not specifically mentioned Our normal payment term is SIGHT DRAFT, Please confirm acceptance in your offer, if you insist for L - C, and all bank charges shall be to your account. Confirm acceptance.

b) Please specify whether any export clearance is required in case of an order on you.

c) Warranty - Guarantee applicable for the item shall be mentioned in your offer

d) Special Certification for packing Material : as per Plant Quarantine (Regulation of Control into India) Order 2003, Articles packed with packing material of plant origin namely, hay, straw, wood shavings, wood chips, saw dust, wood waste, wooden pallets, Dunn age Mats, wooden packages, coir pith, pear or sphagnum moss etcetera, will be allowed entry by Customs only with a Phytosanitary Certificate. In

case of a Purchase Order, if you propose to us any of the above material for packing such a certificate issued by your local Plant Quarantine Authority shall be furnished.

e) Confirm whether any Export License is required and for which End User Certificate is to be provided by us, in case of an Order on you. (Enclose format for EUC, if applicable)

f) Either Indian Agent on behalf of the foreign principals or the foreign principal directly can quote against this order, but not both. In either case an Indian agent cannot represent more than one principal against the same tender.

g) In case the quote is in INR we prefer to execute the same on HSS Basis and for which Concessional Customs duty as per Notification number 50 - 2017 Customs dated 30.06.2017, Serial Number 539(A) as amended by Notification number 05 - 2018 dated 25.01.2018 and vide Notification No.05-2025 dt.01.02.2025 and 45-2025 dtd 24.10.2025. In case the quote is on Indian Rupee (Outside High Sea Sale), the price shall include taxes and duties if any. We shall not be able to provide any duty or IGST tax exemption - concession certificates. If the item quote is of USA make, please quote for all-inclusive price since we prefer to get the item on FOR destination basis.

h) Any bidder from a country which shares a land border with India will be eligible to bid in any procurement whether of goods, services (including consultancy services and non-consultancy services) or works (including turnkey projects) only if the bidder is registered with Competent Authority as specified in Office Memorandum number F.No.6 - 18 - 2019-PPD, Ministry of Finance, Department of Expenditure, Public Procurement Division dated 23rd July 2020. All the conditions mentioned in the above OM is applicable for this tender.

E) Common terms to Indigenous and foreign suppliers:

a.Warranty

You shall provide applicable warranty for the items offered by you without fail. For the applicable period you shall provide necessary warranty certificate.

b.Performance Bank Guarantee

Towards the performance of the systems during the warranty period you shall submit a performance bank guarantee equivalent to 3 percent of the order value to cover the warranty period. This PBG shall be interest free and the same shall be returned to you on successful completion of all contractual obligations. The said PBG shall have a further claim period of 2 months.

c.Security Deposit

On acceptance of the order, you shall submit an interest free amount equivalent to 3 percent of the total contract - order value towards security deposit. This security deposit is collected towards the performance of the Contract. The said Security Deposit shall be submitted either in the form of Bank Guarantee - Demand Draft - FDR receipts duly endorsed in the name of the centre. The Security Deposit will be returned to you on successful completion of the Contractual obligations; failing which it shall be forfeited - adjusted.

4.Offer Validity

Your offer shall be valid for 180 days in case of 2 part - 90 days in case of single part from the date of tender opening. In case your offer validity is less than the mentioned above, the said offer is liable for rejection which may please be noted.

5. Liquidated Damages:

If you fail to deliver the ordered items satisfactorily within the time specified or any extension thereof,

Liquidated Damage at 0.5 percent (zero point five percent) of the order value or part thereof the undelivered items for each calendar week of delay shall be recovered from your bill. However total Liquidated Damage shall not exceed 10 percent (ten percent) of the order value.

6.FORCE MAJEURE:

Should a part or whole work covered under this contract be delayed in delivery - completion of work due to reasons of Force majeure which shall include legal lockouts, strikes, riots, civil commotion, fire, accidents, quarantines, epidemic, acts of God and War, stoppage of deliveries by the Government, freight embargoes etcetera; the delivery period - completion of work referred to in this Contract shall be extended by a period not in excess of duration of such Force Majeure. The occurrence shall be notified by either party within reasonable time.

Note:

I.Offers received through post, courier, fax or email will not be considered.

II.Technical and commercial bid (Part-I) shall not contain any price details. Optional accessories or other price details, if any shall be uploaded in Supporting documents related to Price Bid, to be opened along with Price Bid.

III.In respect of FIM being issued, the fabricator shall submit Bank Guarantee for equivalent sum compulsorily. In case, submission of Bank Guarantee is not possible, the reasons there for shall be clearly mentioned. However, for such cases the fabricators at their cost shall secure such FIM through Insurance Policy with Director, SDSC SHAR as beneficiary. In case of PSU and Government Organization, Indemnity Bond in lieu of Bank Guarantee is acceptable. Balance FIM - Scrap, if any shall be returned along with the supply of the items. Please confirm acceptance in your quotation.

IV.SDSC SHAR shall have the right to place part order among the parties for the items for which they are the lowest.

V.TERMS AND CONDITIONS IN THE RFP SHALL PREVAIL OVER OTHER TERMS AND CONDITIONS(in case of any contradiction or ambiguity)

4. General Instructions to Vendor

1. Instructions to tenderers

TeleNo.08623-225174/225127

Fax No.08623-225170/22-5028

e-Mail ID : hps@shar.gov.in, sselvan@shar.gov.in, psovalf@shar.gov.in

1. Interested tenderers may, at their option, login to <https://eproc.isro.gov.in> and submit your offers.

2. TENDER FEE IS NOT APPLICABLE.

3. EARNEST MONEY DEPOSIT IS NOT APPLICABLE IF NOT MENTIONED IN THE RFP SPECIFICATION.

4. Indian agents while quoting on behalf of their principals are requested to attach Principals original

quote, necessary authorization letter from their Principals, copy of agency agreement etc. in their bid.

5. TWO PART BIDS: In case of Two part tender, price details shall not be uploaded in the Technical & Commercial Bids (Part I), failing to which the bid will be treated as INVALID.

6. The offer should be valid for a minimum period of 180 days for 2 part / 90 days for single part from the date of opening.

7. Due date & time: Sufficient time has been allotted for Bid submission. Vendors are requested to complete Bid submission well in advance. Last minute requests for due date extension citing server problems etc. will not be entertained. Bids will not be entertained after the due date and time.

7 (A). Request for the extension of the due date will not be considered.

8.

(a) Bid Opening for Public Tender: In case of Public Tender-Two Part Tenders: Technical and Commercial Bids will be opened on the first day specified for Tender opening. Interested vendors can attend the tender opening session to know the bidding details (Bidders presence is not mandatory to consider the quote for evaluation). Price Bid opening of the selected vendors will be scheduled later and it will be intimated to the selected Bidder (s).

(b) For Limited Tender: Bidders participation is not allowed.

9. Prices are required to be quoted according to the units indicated.

10. Preference will be given to those tenderers offering supplies from ready stocks and on the basis of FOR destination delivery at site.

11. (a) All available technical literature, catalogues and other data in support of the specifications and detail of the items should be furnished as attachments.

(b) Samples, if called for, should be submitted free of all charges by the tenderer and the Purchaser shall not be responsible for any loss or damage thereof due to any reason whatsoever. In the event of non-acceptance of tender, the tenderer will have to remove the samples at his own expense.

(c) Approximate net and gross weight of the items offered shall be indicated in your offer. If dimensions details are available the same should be indicated in your offer.

(d) Specifications: Stores offered should strictly conform to our specifications. Deviations, if any, should be clearly indicated by the tenderer in their quotation. The tenderer should also indicate the Make/Type number of the stores offered and provide catalogues, technical literature and samples wherever necessary. Test certificates wherever necessary should be attached. Whenever options are called for in our specifications, the tenderer should address all such options. Wherever specifically

mentioned by us the tenderer could suggest changes to specifications with appropriate response for the same.

12. The purchaser shall be under no obligation to accept the lowest or any tender and reserves the right of acceptance of the whole or any part of the tender or portion of quantity offered and the tenderers shall supply the same at the rates quoted.

13. All amounts shall be indicated both in words as well as in figures. Where there is difference between amounts quoted in words and figures, amount quoted in words shall prevail.

14. The tenderer will be required to furnish a document containing the name of his bankers as well as the latest income-tax clearance certificate duly counter signed by the Income-tax Officer of the Circle concerned under the Seal of his office, if required by the Purchaser.

15. The Purchaser reserves the right to place order on the successful tenderers for additional quantity up to 25% of the quantity offered by them at the rates quoted.

16. Sr. Head, Purchase and Stores, SDSC SHAR SRIHARIKOTA reserves the right to accept or reject any bid in part or full without assigning any reason thereof.

17. Any bidder from a country which shares a land border with India will be eligible to bid in any procurement whether of goods, services (including consultancy services and non-consultancy services) or works (including turnkey projects) only if the bidder is registered with Competent Authority as specified in Office Memorandum no.F.No.6/18/2019-PPD, Ministry of Finance, Department of Expenditure, Public Procurement Division dated 23rd July 2020. All the conditions mentioned in the above OM is applicable for this tender.

C. Bid Templates

C.1 Technical Bid - Fabrication, Supply, Installation and Commissioning of Modular Executive Consoles, executive chairs, racks for SSLV Launch Complex (SLC), Kulasekarapatnam

1. CONSOLE COMPONENT-

Fabrication and Supply of 3-Bay Modular control console as per the specifications-1 of section-B of this RFP document.----Category –1

2. CONSOLE COMPONENT-

Fabrication and Supply of 3-Bay Modular control console as per the specifications-1 of section-B of this RFP document.-----Category-2

3. CONSOLE COMPONENT-

Fabrication and Supply of 2-Bay Modular control console as per the specifications-1 of section-B of this RFP document.-----Category-2

4. CONSOLE COMPONENT-

Fabrication and Supply of 6-Bay Modular control console as per the specifications-1 of section-B of this RFP document.-----Category-2

5. CONSOLE COMPONENT-

Fabrication and Supply of 1-Bay Modular control console as per the specifications-1 of section-B of this RFP document..-----Category-2

6. CONSOLE COMPONENT-

Fabrication and Supply of 3-Bay Modular control console as per the specifications-1 of section-B of this RFP document.-----Category-3

7. Chair-

Supply of Executive chairs (24x7 control room chairs) for the console as per the specifications-2 of section-B of this RFP document.-----Category-1

8. Chair-

Supply of Executive chairs (24x7 control room chairs) for the control console as per the

specifications-2 of section-B of this RFP document.-----Category-2

9. Chair-

Supply of Executive chairs (24x7 control room chairs) for the control console as per the specifications-2 of section-B of this RFP document.-----Category-3

10. Chair-

Supply of VIP/VVIP Gallery chair as per the specifications-3 of section-B of this RFP document.

11. KVM OVER IP SWITCH -

Supply of 8-port KVM Switch per the specifications- 4 of section-B of this RFP document

12. KVM OVER IP SWITCH -

Supply of 4-port KVM Switch per the specifications- 4 of section-B of this RFP document

13. Network racks-

Supply of 42U Network/Instrumentation rack (600mm x 800mm) as per the specifications-5 of section-B of this RFP document

14. Network racks-

Supply of 42U Network/Instrumentation rack (800mm x 1000mm) as per the specifications-5 of section-B of this RFP document

15. INSTALLATION AND COMMISSIONING -

Installation & Commissioning of control consoles, chairs, gallery chairs, racks and KVM switches at SLC site

Common Specifications (Applicable for all items)

SI No	Specification	Value	Compliance	Offered Specification	Remark
-------	---------------	-------	------------	-----------------------	--------

1	Party shall accept all the technical specifications and commercial terms & conditions given in the RFP.	Accepted	Yes / No / Explain		
2	The consoles, chairs, KVM Switches and racks, as per the quantities mentioned in this RFP document, are to be delivered at SLC site and they are required to be installed in various technical facilities located within SLC site.	Accepted	Yes / No / Explain		
3	The supplied items are to be taken inside the buildings for installation through staircase and doors of standard size. No lift facility/Material handling support will be provided by SDSC SHAR for moving the items inside technical facilities.	Accepted	Yes / No / Explain		
4	The vendor shall arrange all necessary tools and handling equipment including the required manpower for installation of items at SLC site.	Accepted	Yes / No / Explain		

5	All the items shall be properly packed and transported during delivery as per industry standard	Accepted	Yes / No / Explain		
---	---	----------	--------------------	--	--

Supporting Documents required from Vendor

- 1. Vendor shall submit all the supporting documents as per RFP document.**
- 2. UDYAM Certificate if Claiming Purchase Preference under MSE**
- 3. MII Self-declaration indicating percentage of local content and address of value addition**
- 4. Upload Land Boarder Sharing Declaration**
- 5. Turnover of last three FY**
- 6. Experince certificate as mentioned in the attached RFP**
- 7. Annual turnover**
- 8. Current Solvency Certificate for an amount of Rs. 150 Lakhs**
- 9. Technical Literature**
- 10. Firm establishment certificate and nature of work**
- 11. OEM authorization certificate.**
- 12. Structure and organization chart**
- 13. List of personnel with qualification and experience**
- 14. Any other docuements as mentioned in the RFP**

5 additional documents can be uploaded by the vendor

C.2 Commercial Terms / Bid

Sl. No.	Description	Compliance	Vendor Terms
1	The seller shall take the responsibility of supplying all the items as per quantities and terms & conditions mentioned in this RFP document.	Yes / No / Explain	
2	The items are to be supplied to SLC site, Kulasekarapatnam, Tuticorin(Dt) Tamilnadu.	Yes / No / Explain	
3	HSN/SAC code shall be indicated for each item and accordingly mention the GST Rate applicable as per prevailing guidelines.	Yes / No / Explain	
4	Please confirm here whether your quoted "UNIT PRICE" in our Price Bid is EXCLUDING GST or INCLUDING GST. ----- NOTE: If you are not clearly stating "GST is Inclusive OR Extra in basic cost" it will be treated as "GST is included in the quoted Basic/Unit cost in the price bid". Your offer will be evaluated as INCLUSIVE OF GST.	Yes / No / Explain	
5	Delivery Term FOR : SSLV Launch Complex (SLC), Kulasekarapatnam(MANDATORY)	Yes / No / Explain	
6	Delivery Period required for delivery of the items/completion of total scope of work: Delivery Period required for delivery of the items/completion of total scope of work: 20 weeks as indicated in the RFP at para no. 15	Yes / No / Explain	

7	<p>Payment Term: Note: (a) For advance payment, Bank Guarantee from any commercial bank on Rs.200 non-judicial stamp paper should be furnished for the equivalent amount as per the format issued by SDSC SHAR valid till completion of total scope of work plus 60 days.</p> <p>(b) After drawl of advance payments, if the vendor/supplier is not supplying the material within the delivery schedule, the advance amount will be recovered and interest will be levied as per the RBI Prime Lending Rate or similar rate published by RBI plus 2% penal interest.</p> <p>(c) In case of any delay attributable to the contractor/supplier in effecting the supply after the prescribed delivery date. Interest at RBI Prime Lending Rate or similar rate published by RBI will be charged for the period beyond the specified delivery date, on the amount of balance advance payment in addition to LD.</p> <p>(d) Interest will be loaded for advance payments/stage payments as per the RBI Prime Lending Rate or similar published by RBI and will be added to the landed cost for comparison purpose.</p>	Yes / No / Explain	
8	<p>Warranty/Guarantee: Warranty/Guarantee for the offered item shall be from the date of acceptance of the item at our site for a minimum period of three years as specified in the tender document.</p>	Yes / No / Explain	
9	<p>Liquidated Damages (LD) :- Since delivery is the essence of this order, LD @ 0.5% per week or part thereof subject to a maximum of 10% of the order value for the delayed period of supply.</p>	Yes / No / Explain	
10	<p>Security Deposit (SD) 3% value of the order shall be deposited with SDSC within 10 days from the date of the Purchase Order towards security deposit in the form of Bank Guarantee(BG)/ FDR/DD towards performance of the Contract valid till completion of the contract period plus sixty days towards claim period. (This will be returned by SDSC immediately on execution of the order satisfactorily as per order terms. If not, the amount will be forfeited).</p>	Yes / No / Explain	

11	<p>Performance Bank Guarantee (PBG)</p> <p>You have to submit a BG/DD/FDR in lieu of PBG from a Nationalized / Scheduled Bank for 3% of the order value at the time of supply valid till the completion of warranty period plus 60 days towards claim period.</p>	Yes / No / Explain	
12	<p>Combined BG for PBG cum SD</p> <p>In case, if parties are unable to provide two separate BGs, i.e., one for SD & one for PBG, they can submit a combined BG for SD & PBG for 3% of the Order value valid till the completion of total contractual obligation (i.e., Supply period plus warranty period plus 60 days). Please confirm.</p>	Yes / No / Explain	
13	<p>Insurance</p> <p>Being a Govt. Of India Dept., Insurance is not required at our cost. Please ensure the safe delivery of the ordered item with proper transport worthy packing.</p>	Yes / No / Explain	
14	<p>Validity of Offer</p> <p>In case of single part tender - the validity of offers/tenders should be 90 days. In case of two part tender - 120 days from the date of opening of Part-I bid and 60 days from the date of opening of Part-II bid. Tenders shorter than offer validity mentioned above will not be considered for evaluation.</p>	Yes / No / Explain	
15	<p>The bidder shall provide compliance to Order No. F.No.7/10/2021 PPD dated 23.02.2023 and amendments thereof by Ministry of Finance, Department of Expenditure, Public Procurement Division regarding restrictions on procurement from a bidder of a country which shares a land border with India and comply to all the provisions of the Order. In this regard, you shall certify that the bidder entity is not from such a country or, is from such a country, has been registered with the Competent Authority.</p>	Yes / No / Explain	
16	<p>As per the above Order, are you (the Bidder/Company/Entity) OR offering product/service is from such a Country sharing Land border with INDIA.</p>	Yes / No / Explain	

17	<p>Make-In-India (MII) Clause: Provisions contained in Public Procurement Policy (Preference to Make in India), Order 2017 issued by DPIIT vide OM No. P-45021/2/2017-PP(BE-II) dated 16.09.2020 & directives related including latest amendments (if any) is applicable for this tender.</p> <p>You are requested to provide Self Declaration Certificate that the offered Item meets Local Content Requirement of Class 1 or Class 2 as per Make in India(MII) Policy, clearly indicating the Percentage of local content & the details of Location(s) at which value addition is made in the offered product.</p> <p>It may be noted that Local Content shall not include services such as Transportation, Insurance, Installation, Commissioning, Training and after sales service support like AMC/CMC etc.</p>	Yes / No / Explain	
18	<p>Please mention in PERCENTAGE the Value addition of offered products happened in INDIA in line with Make In India Policy. (Mandatory). You have to upload MII Declaration mentioning place and percentage of value addition along with Offer.</p>	Yes / No / Explain	

19	<p>Purchase preference to Micro and Small Enterprises (MSEs): Purchase preference will be given to MSEs as defined in Public Procurement Policy for Micro and Small Enterprises (MSEs) Order, 2012 dated 23.03.2012 issued by Ministry of Micro, Small and Medium Enterprises and its subsequent Orders/Notifications issued by concerned Ministry. If the bidder wants to avail the Purchase preference, the BIDDER MUST BE MANUFACTURER OF THE OFFERED PRODUCT in case of bid for supply of goods. TRADERS ARE EXCLUDED from the purview of Public Procurement Policy for Micro and Small Enterprises. In respect of bid for Services, the bidder must be the Service provider of the offered Service. Relevant documentary evidence along with UDYAM REGISTRATION in this regard shall be uploaded along with the bid in respect of the offered product or service. If L-1 is not an MSE and MSE Seller (s) has/have quoted price within L-1 plus 15% (Selected by Buyer) of margin of purchase preference/price band defined in relevant policy, such Seller shall be given opportunity to match L-1 price and contract will be awarded for 25% (selected by Buyer) percentage of total QUANTITY.</p>	Yes / No / Explain	
20	<p>Are you claiming MSME Preference for this tendered item/service?</p> <p>Note: You should have been the MANUFACTURER of the offered product or SERVICE Provider of the said service (in service tender) as per your MSME Registration. (If YES, valid Udyam Registration documents shall be uploaded. Otherwise your claim will not be considered. False declarations will be in breach of the Code of Integrity under Rule 175(1)(i)(h))</p>	Yes / No / Explain	
21	<p>Please Select for the offered Product whether you are: (1) Manufacturer (2) Authorized Agent (3) Distributor (4) Dealer (5) Reseller (6) Others</p>	Yes / No / Explain	

22	Do you have Unique GeM Seller ID? If YES, provide details If NO, As per Office Memorandum No 6/9/2020-PPD dated 24/08/2020 of Department of Expenditure, it shall be mandatory for sellers providing Goods and Services to Central Government Organizations to be registered on GeM and obtain a Unique GeM Seller ID, at the time of Placement of Order/acceptance of contract. Tenderers shall ensure the same.	Yes / No / Explain	
23	Address on which PO is to be placed and GSTIN	-	
24	Please provide valid/currently using E-mail Id & Contact no. for seeking further clarifications if any	-	
25	Remarks if any.	-	
26	Please quote in INR only. Quotes received in foreign currency shall be summarily rejected.	Yes / No / Explain	

C.3 Price Bid

Sl. No.	Item	Quantity	Unit Price	Currency	Total Price	Remark
1	CONSOLE COMPONENT- Fabrication and Supply of 3-Bay Modular control console as per the specifications -1 of section-B of this RFP document.---- Category -1	18.00 Nos.		-		
2	CONSOLE COMPONENT- Fabrication and Supply of 3-Bay Modular control console as per the specifications -1 of section-B of this RFP document.---- -Category-2	22.00 Nos.		-		

3	<p>CONSOLE COMPONENT- Fabrication and Supply of 2-Bay Modular control console as per the specifications -1 of section-B of this RFP document.---- -Category-2</p>	8.00 Nos.		-		
4	<p>CONSOLE COMPONENT- Fabrication and Supply of 6-Bay Modular control console as per the specifications -1 of section-B of this RFP document.---- -Category-2</p>	1.00 Nos.		-		
5	<p>CONSOLE COMPONENT- Fabrication and Supply of 1-Bay Modular control console as per the specifications -1 of section-B of this RFP document..--- --Category-2</p>	2.00 Nos.		-		
6	<p>CONSOLE COMPONENT- Fabrication and Supply of 3-Bay Modular control console as per the specifications -1 of section-B of this RFP document.---- -Category-3</p>	10.00 Nos.		-		

7	Chair-Supply of Executive chairs (24x7 control room chairs) for the console as per the specifications -2 of section-B of this RFP document.---- -Category-1	90.00 Nos.				
8	Chair-Supply of Executive chairs (24x7 control room chairs) for the control console as per the specifications -2 of section-B of this RFP document.---- -Category-2	82.00 Nos.				
9	Chair-Supply of Executive chairs (24x7 control room chairs) for the control console as per the specifications -2 of section-B of this RFP document.---- -Category-3	21.00 Nos.				
10	Chair-Supply of VIP/VVIP Gallery chair as per the specifications -3 of section-B of this RFP document.	109.00 Nos.				
11	KVM OVER IP SWITCH - Supply of 8-port KVM Switch per the specifications - 4 of section-B of this RFP document	9.00 Nos.				

12	KVM OVER IP SWITCH - Supply of 4-port KVM Switch per the specifications - 4 of section-B of this RFP document	2.00 Nos.				
13	Network racks- Supply of 42U Network/Instrumentation rack (600mm x 800mm) as per the specifications -5 of section-B of this RFP document	23.00 Nos.				
14	Network racks- Supply of 42U Network/Instrumentation rack (800mm x 1000mm) as per the specifications -5 of section-B of this RFP document	29.00 Nos.				
15	INSTALLATION AND COMMISSIONING - Installation & Commissioning of control consoles, chairs, gallery chairs, racks and KVM switches at SLC site	1.00 Lot				

REQUEST FOR PROPOSAL (RFP)

for

**Fabrication, Supply, Installation and Commissioning
of Modular Executive Consoles, executive chairs, racks for
SSLV Launch Complex (SLC), Kulasekarapatnam.**

PROJECT : SSLV Launch Complex Project

LOCATION: SLC Site, Kulasekarapatnam, Tuticorin, Tamilnadu.



June, 2026

**SATISH DHAWAN SPACE CENTRE
SRIHARIKOTA-524124.
INDIAN SPACE RESEARCH ORGANISATION**

PROPOSAL DOCUMENT, CLARIFICATION AND ADDENDUM

Satish Dhawan Space Centre, Indian Space Research Organization (ISRO), Sriharikota is planning to procure consoles, executive chairs and racks for control room applications at SLC site.

The scope of work pertains to fabrication, supply, installation, testing and commissioning of the Modular Consoles, racks and executive chairs at SSLV Project Office (SLC Site), Survey No. 260-3C, Madhavankurichi Village – 628206, opp. to Koodal Nagar, Thiruchendur Tk., Thoothukudi Dist., Tamilnadu.

Online Quotations are invited from the interested bidders through ISRO e-procurement portal for the enclosed scope of work in two-part bid.

Part-1: Techno-commercial & Unpriced part of the work.

Part-2: Priced commercial part.

Part-I: Techno-commercial Bid

This part shall contain only the technical details and specifications along with technical catalogues. Vendor/Bidder shall mention point-wise confirmation with regard to Technical Specifications and terms & conditions given in our Enquiry. No price details shall be mentioned in this bid. Otherwise, such offers (in case of revealing price information in Part-I) will be summarily rejected.

Part-II: Price Bid

The vendor shall quote the consolidated price for indented items. However, the vendor should also upload details (breakup cost details for each of the item) as per Form II. PRICE BID FORMAT of Section-C. **Price details should be mentioned in the Price Bid only.** No price details shall be mentioned in Techno-commercial bid. Otherwise offers will be summarily rejected.

The RFP document is organized in three sections as follows.

Section –A Commercial Terms and Conditions of the Contract

Section –B Technical Specifications & Functional requirements.

Section –C Forms.

SECTION –A

COMMERCIAL TERMS AND CONDITIONS OF THE CONTRACT

1. INTRODUCTION

As part of SSLV Launch Complex (SLC) project, SDSC SHAR/ISRO is realizing many control room facilities at SLC site for monitoring and controlling all operations during launch campaign. Data and information pertaining to various facilities will be monitored through Computer monitors and CCTV displays round the clock for operations & control purpose. The executive consoles are required to house the displays, monitors and associated equipment like communication unit, timing unit, Hold & Release switches etc. for easy and secure operations. The racks are required for vertical integration of instruments, with better cable and thermal management.

2. BID SUBMISSION

Bids duly filled in by the Bidder should invariably be submitted as stipulated in the Letter inviting bid. Bids shall be submitted in the following manner.

2.1 UNPRICED TECHNO-COMMERCIAL PART OF THE BID

Complete Techno-commercial part of the bid shall be filled online in the “Vendor Specified Terms’ form of **ISRO e-procurement portal** (<https://eproc.isro.gov.in>). Any documents related to technical literature, guarantee /warranty certificates and any other documents required to support the bid shall be scanned and uploaded along with the techno-commercial bid.

Technical and unpriced commercial bid shall comprise the attachments, specifying attachment number arranged in the order as follows:

- a) Submission of bid letter along with one set of proposal document (RFP) duly signed and stamped as token of acceptance of all terms and conditions mentioned in the RFP document.
- b) All the forms enclosed in proposal duly filled, signed and sealed.
- c) Unpriced copy of schedule of prices with all other commercial terms, taxes, duties, exemption certificates and conditions duly filled (Prices to be kept blank), signed and stamped as per the format in Form-II of Section-C.
- d) Data sheets & checklists enclosed in proposal duly filled, signed, &

SLC RANGE FACILITIES – MODULAR CONSOLES, INSTRUMENTATION RACKS and CHAIRS

- stamped.
- e) Technical details, catalogue, etc. as applicable and any other supporting as mentioned in the proposal or /relevant documents which bidder desires to submit.
 - f) Any bids/offers with price details revealed in Techno-Commercial Offer shall be rejected.
 - g) Bidder must submit the configuration design based on the conceptual drawing enclosed in the technical specifications of Section-B.
 - h) The bidder shall furnish point-wise confirmation for the technical specifications given in the enquiry. However, change of specifications/ deviations (if any) shall be brought out in the offer as deviation summary with detailed justification. Exclusions, if any from scope of supply shall be clearly indicated in the offer.
 - i) Commercial conditions with reference to supply of the items shall be given in Techno-Commercial Offer part. This shall include all conditions like delivery terms, delivery period, Taxes & duties applicable, Payment terms, Guarantee / Warrantee, Price Validity and any other conditions without mentioning the price.
 - j) Bidder need to furnish the details related to commercial terms indicating payment terms, details of bank guarantee in case of advance payments etc.
 - k) Bidder shall indicate clearly the delivery/time period for supplying the items to SLC site.
 - l) Bidder need to submit unpriced price bid copy (as highlighted below) indicating the description of all the cost elements considered, without indicating the price. Bidder shall note that indication of price in the techno-commercial bid shall lead to dis-qualification of bid.

FORMAT OF UN-PRICED PRICE BID:

The schedules of the quantities are as follows:

S. No	Item Description		Qty	Compliance
1	Fabrication and Supply of 3-Bay Modular control console as per the specifications-1 of section-B of this RFP document.	Category -1	18	YES/NO

SLC RANGE FACILITIES – MODULAR CONSOLES, INSTRUMENTATION RACKS and CHAIRS

2	Fabrication and Supply of 3-Bay Modular control console as per the specifications-1 of section-B of this RFP document.	Category-2	22	YES/NO
3	Fabrication and Supply of 2-Bay Modular control console as per the specifications-1 of section-B of this RFP document.		8	YES/NO
4	Fabrication and Supply of 6-Bay Modular control console as per the specifications-1 of section-B of this RFP document.		1	YES/NO
5	Fabrication and Supply of 1-Bay Modular control console as per the specifications-1 of section-B of this RFP document.		2	YES/NO
6	Fabrication and Supply of 3-Bay Modular control console as per the specifications-1 of section-B of this RFP document.	Category-3	10	YES/NO
7	Supply of Executive chairs (24x7 control room chairs) for the console as per the specifications-2 of section-B of this RFP document.	Category -1	90	YES/NO
8	Supply of Executive chairs (24x7 control room chairs) for the control console as per the specifications-2 of section-B of this RFP document.	Category -2	82	YES/NO
9	Supply of Executive chairs (24x7 control room chairs) for the control console as per the specifications-2 of section-B of this RFP document.	Category -3	21	YES/NO
10	Supply of VIP/VVIP Gallery chair as per the specifications-3 of section-B of this RFP document.		109	YES/NO
11	Supply of 8-port KVM Switch per the specifications- 4 of section-B of this RFP document		9	YES/NO
12	Supply of 4-port KVM Switch per the specifications- 4 of section-B of this RFP document		2	YES/NO
13	Supply of 42U Network/Instrumentation rack		23	YES/NO

SLC RANGE FACILITIES – MODULAR CONSOLES, INSTRUMENTATION RACKS and CHAIRS

	(600mm x 800mm) as per the specifications-5 of section-B of this RFP document		
14	Supply of 42U Network/Instrumentation rack (800mm x 1000mm) as per the specifications-5 of section-B of this RFP document	29	YES/NO
15	Installation & Commissioning of control consoles, chairs, gallery chairs, racks and KVM switches at SLC site	1 lot	YES/NO

Table-1 Un-priced price bid format.

- **Bidder shall submit the unpriced Techno-commercial bid with the following set of documents with required mandatory details.**
 - Compliance by vendor to all Technical & commercial specifications of this RFP document.
 - Form-I – Overall Compliance Statement form.
 - Form-III (Evaluation Criteria),
 - Form-IV (if any deviations and exceptions with our tender specifications),
 - Form V – Bidder General Information form.
 - Form VI - Experience in doing similar works in India.
 - Form VII – Letter of Authorization.
 - Form-VIII - Compliance Statement form.
 - Compliance to Bidder Eligibility Criteria (clause-5 of section-A of this RFP document) and
 - Any other information (only relevant to this tender) shall be uploaded in ISRO e-procurement portal under ‘Documents solicited from Vendor’.
- Price bid annexures **shall not be** enclosed/uploaded with unpriced Techno-commercial bid.

2.2 PRICE PART OF THE BID

Price bid shall be submitted in the relevant “price-bid” form (as shown in **Form-II of Section-C**) in the ISRO e-procurement portal. **The price schedules and other price details shall be uploaded on-line in the respective forms along with the price bid in ISRO e-procurement portal.**

- a. SDSC may open **Technical and unpriced commercial bid** on the due date of opening subject to meeting the minimum evaluation criteria. Price Bids of technically and commercially acceptable offers shall be opened at a later date.
- b. All rates should be mentioned in Indian rupees. Bidder shall quote the prices on “FOR-SLC Site, Kulasekarapatnam, Tuticorin, Tamilnadu”.
- c. Price quoted in ISRO e-Procurement portal will only be considered for

SLC RANGE FACILITIES – MODULAR CONSOLES, INSTRUMENTATION RACKS and CHAIRS

- evaluation and that will prevail over any price information mentioned in any other form or location.
- d. The price quoted shall be on FOR DESTINATION BASIS i.e., FOR SLC Site basis. Transportation of material from bidder's works to SLC site and unloading at SLC site is the responsibility of bidder. Department will not provide any material handling support and tools for unloading at site and the same shall be arranged by supplier.
 - e. Bidders are advised to indicate all taxes explicitly in the price bid. If lump-sum cost is quoted, it will be presumed that quoted rates are inclusive of taxes & duties and no claim in this regard will be entertained later.
 - f. Bidder has to consider entire Bill of Material required for installation and commissioning and it should be indicated in the proposal.
 - g. SDSC SHAR reserves the right to reject any or all the Bids without assigning any reasons thereof.
 - h. Total amount shall be spelled out in numbers and words also. If there is conflict between numbers and words, words mentioned in ISRO e-Procurement portal will be deemed final.
 - i. **No deviations, terms and conditions, assumptions, conditions, discounts etc. shall be stipulated in price bid. Department will not take cognizance of any such statement and may at their discretion reject such bids.**
 - j. The price bid format is shown in **Form-II of section-C**.

3. VALIDITY OF OFFER

Bid shall remain valid for acceptance for a minimum period of **120 days (One hundred and twenty days)** from the due date of submission of the Bid. The Bidder shall not be entitled during the said period to revoke or revise his/her Bid or to vary the Bid except and to the extent required by SDSC SHAR in writing. Bid shall be revalidated for extended period as required by SDSC SHAR in writing. In such cases, unless otherwise specified, it is understood that validity is sought and provided without varying either the quoted price or any other terms & conditions of Bid finalized till that time.

4. COST OF BIDDING

The bidder shall bear all the costs and expenditure incurred and/or to be incurred by them in preparation, and uploading the tender including attending the pre-bid meeting and or arranging demonstration of Product/Services or Field trials that may be deemed necessary by the Purchaser. SDSC-SHAR will in no case be responsible or liable for those costs, regardless of the conduct or outcome of the bid process.

5. BIDDER ELIGIBILITY CRITERIA:

SLC RANGE FACILITIES – MODULAR CONSOLES, INSTRUMENTATION RACKS and CHAIRS

Bid is open to all OEMs of control consoles and executive rooms for control rooms and also to their authorised representatives of OEMs. The following are the minimum essential criteria to further validate/accept the bid submitted by the vendor/bidder. Vendor/Bidder is requested to provide all the necessary supporting documents. In case of any deviation/non-compliances/lack of supporting document, the concerned bid shall be summarily rejected.

5.1 PRE-QUALIFICATION CRITERIA:

The Bidder should be registered in India and necessary PAN certificate shall be submitted. The bidder shall submit a separate compliance statement for all the following points as part of the techno-commercial offer.

S. No	Description	Compliance
1	The Bidder should be registered in India since last 5 (five) years or more as on 31-03-2026. Company Profile along with documentary evidence of services offered and all relevant enclosures to be submitted. Bidder/OEM shall be an organization with experience more than three years as on 31.03.2026 in manufacturing, supply and installation of control consoles and control room chairs to the Public /Major Private Registered Organizations. Experience in manufacturing/supplying general office furniture will not be considered.	
2	If bidder is not an OEM, Valid license partner certificate / system integrator certificate & endorsement letter from OEM shall be submitted to participate in this particular tender by authorized representatives.	
3	The bidder/vendor shall provide the following information about his/her firm while submitting the bid. <ul style="list-style-type: none">➤ Company Name➤ Year of Establishment➤ Registered Address➤ Manufacturing Facility Address➤ Type of Organization (Manufacturer / OEM / Authorized Dealer / Trader)➤ Total Employees➤ Factory Area (sq. meters)➤ Annual Turnover (Last 3 Years)➤ Contact Person (Technical)➤ Contact Person (Commercial)	
5	Within the recent four financial years starting from 1.4.2022 ending 31.03.2026, the bidder should have successfully completed either of the following similar works; <ul style="list-style-type: none">➤ One Similar completed work order (of supplying	

SLC RANGE FACILITIES – MODULAR CONSOLES, INSTRUMENTATION RACKS and CHAIRS

S. No	Description	Compliance
	<p>control consoles and executive chairs for control room applications) not less than Rs. 300 Lakhs.</p> <ul style="list-style-type: none"> ➤ Two similar completed work orders (of supplying control consoles and executive console chairs for control room applications) not less than Rs. 150 Lakhs each. ➤ Three similar completed work orders (of supplying control consoles and executive console chairs for control room applications) not less than Rs. 100 Lakhs each. 	
6	<p>The Bidder's annual financial turnover shall be not less than Rs. 200 lakhs per year during last three financial years ending with 31.03.2026. Supplier shall submit audited financial balance sheets along with Purchase Orders. Self declaration for financial year 2025-26 shall be submitted.</p>	
7	<p>PO copies and Satisfactory Work completion certificates by the end user for the previous executed orders of similar offered items/services shall be submitted without which offer will not be considered.</p>	
8	<p>Audited balance sheet & Profit & Loss A/c is to be submitted (or) Copy of the IT return filed / audited last 3 years financial statements for Financial years ending with 31.03.2026.</p>	
9	<p>Vendor must undertake Design, supply, installation and commissioning of control consoles, racks and executive chairs as per the specifications and requirements indicated in the RFP.</p>	
10	<p>The vendor/Bidder or the OEM shall have the required the following Technical & Design Capability. The mandatory documentary proofs shall be submitted along with the bid.</p> <ul style="list-style-type: none"> ➤ Custom design capability ➤ 3D modeling & CAD drawings ➤ Ergonomic layout design (monitor positioning, reach zones) ➤ Heat dissipation design. ➤ Structural Design capability to analyze Load-bearing capacity of consoles and chairs. ➤ Bidder's Compliance with Ergonomic Standards, BIFMA Standards, Greenguard Gold/ Greenguard certification, Seismic Zone test certificates and quality control standards. 	

SLC RANGE FACILITIES – MODULAR CONSOLES, INSTRUMENTATION RACKS and CHAIRS

S. No	Description	Compliance
11	The vendor/Bidder shall have the required manufacturing capability in terms of In-house production, factory size, machinery, CNC capability, fabrication facilities and skilled workforce strength. The necessary documents shall be submitted along with the bid as proof for the above said capabilities.	
12	<p>The vendor/Bidder shall provide Testing reports & Certifications for the following for both consoles and chairs.</p> <ul style="list-style-type: none"> ➤ BIFMA test reports. ➤ Greeguard gold/Greenguard certification. ➤ Load test reports for consoles and chairs. ➤ Durability cycle testing reports ➤ Applicable safety certifications. <p>The vendor/Bidder shall provide Seismic Zone V certification/tested report and ASTM E84 Class A fire rating certificate for consoles.</p>	
13	The vendor/Bidder shall have Quality control and management plan including ISO 9001 certification (, Quality inspection procedures, Incoming material inspection records, In-process quality control and Final inspection & testing for both control consoles and chairs.	
14	<p>Offers submitted by trading company without any manufacturing capability/OEM authorisation will be summarily rejected. Similarly, offers submitted by the following vendor/Bidder will be rejected.</p> <ul style="list-style-type: none"> ➤ Not providing factory visit access during bid evaluation and work execution. ➤ Not having the required certifications. ➤ Not submitting the documented test reports of consoles and chairs. 	
15	Technical compliance to the specifications and requirements given in the RFP document shall be vetted by the bidder.	
16	The firm must provide a self-declaration that there is no complaint/vigilance inquiry against them in any Govt. /Department /PSU and they have not been black-listed by any Govt. Department/PSU during the last three years.	
17	Vendor shall submit as solvency certificate for the value of Rs.150 Lakhs. The certificate date shall be within 06 months from the tender date.	

Note:

Proposal of the bidder, which is not able to substantiate/satisfy the claims made by it with respect to the technical requirements laid down in this RFP,

will be summarily rejected. Offers of those bidders taking full scope of work as per the RFP will only be considered.

6. ARRANGEMENT OF BID

The Bid and all details submitted by the Bidder shall be signed and stamped on each page as token of acceptance, by a person legally authorized to enter in to agreement on behalf of the Bidder. (Corrections / alteration, if any, shall also be signed by the same person).

7. GENERAL TERMS AND CONDITIONS

- a) Supplier shall obtain clearance for Configuration of the items from *department* prior to the commencement of design activities.
- b) Supplier must understand the technical requirements of the consoles and racks as per the technical specifications given in Section-B of this document.
- c) Supplier must present computerized 3D models / prototype for clearance by Department at no extra cost.
- d) Supplier must design the console and *obtain the clearance from department before fabrication* as per standard ISO codes (as applicable).
- e) Based on the cleared design, supplier must fabricate, supply, install and commission all the consoles (including the one 3-bay console offered for inspection) to Department.
- f) Supplier must *fabricate one 3-bay console and offer for inspection*. Any minor suggestions made by department must be carried out by supplier at no extra cost, keeping the basic configuration as same.
- g) Supplier must provide necessary service while installing the consoles for exactly matching the cable entries with the false flooring from the bottom of the false floor into the console towards making matching holes to the false flooring.
- h) Supplier also must extend service while fixing the equipment to the consoles at site.

8. MAKE IN INDIA CLAUSE

- a) General Terms & conditions for Bidders: For this procurement, bids from Class-I & Class-II Local Suppliers are admissible. Hence provisions contained in Public Procurement (Preference to Make in India), Order 2017 issued by Department for Promotion of Industry and Internal Trade (DIPP), Ministry of Commerce & Industries vide letter No. P-45021/2/2017-PP(BE-II) dated 04.06.2020 and subsequent amendment & directives shall be followed. Accordingly, offer will be evaluated & processed in conformation with above referred GOI order (Specially mentioned below). The bidder shall provide compliance and undertaking as per order and hereafter amendments:
- b) Order no: F.No.6/18/2019 PPD dated 23.07.2020 of Department of Expenditure), Ministry of Finance Under Public Procurement Division for the General Financial Rule (GFRs).

SLC RANGE FACILITIES – MODULAR CONSOLES, INSTRUMENTATION RACKS and CHAIRS

- c) Class-I local supplier means a supplier or service provider, whose goods, service or works offered for procurement, has local content equal to or more than 50%, as defined under this Order.
- d) Class-II local supplier means a supplier or service provider, whose goods, services or works offered for procurement, has local content more than 20% but less than 50%, as defined under this Order
- e) Verification of local content:
 - I. The Class I local supplier/ Class- II local supplier at the time to tender, bidding or solicitation shall be required to indicate percentage of local content and provide self-certification that the item offered meets the local content requirement for Class-I local supplier / Class II local supplier as the case may be. They shall also give details of the location(s) at which the local value addition is made.
 - II. In case bid value is in excess of Rs. 10 Cr., Class-I local supplier / Class-II local supplier shall be required to provide a certificate from the statutory auditor or cost auditor of the company (in the case of companies) or from a practicing cost accountant or practicing chartered accountant (in respect of suppliers other than companies) giving the percentage of local content.
 - III. False declarations will be in breach of the code of Integrity under Rule 175(1)(i)(h) of the General Financial Rules (GFR) for which a bidder or its successors can be debarred for up to two years as per Rule 151(iii) of the General Financial Rules along with such other actions as may be permissible under Law.
 - IV. A supplier who has been debarred by any procuring entity for violation of this order shall not be eligible for preference under this order for procurement by any other procuring entity for the duration of the debarment.
- f) The percentage of local content should be specifically mentioned in the offer, without which it will be summarily rejected.
- g) Preference will be given to Class-I Local supplier and in their absence, Class-II Local supplier will be considered.
- h) As the project is a package, Make in India Content for each item mentioned in Form-II of Section-C shall be provided with proof from OEM for considering the offer.

9. TECHNICAL DOCUMENTATION AND DRAWINGS

- 9.1** The supplier shall provide soft copy / hard copy of the catalogues, and manuals of all the quoted items.
- 9.2** List of documents to be submitted:
 - a. Technical compliance for the specification.
 - b. Final BOM with Make & Model number.

- c. All technical catalogues and datasheets of all items.
- d. Warranty certificates.
- e. Passwords/ licenses/ operating keys etc., for deployment and unrestricted use at SDSC SHAR.
- f. Operational Manual /Any other relevant document not listed above, as requested by SDSC SHAR during the contract period shall be provided.

10. PROPOSAL DOCUMENT & BID PREPARATION

- 10.1** Bidder shall sign & stamp each page of the tender document (RFP) as token of his/her acceptance and submit the same along with the offer.
- 10.2** Proposal document shall remain the property of *SDSC SHAR* and shall not be used for any another purpose without the consent of *SDSC SHAR*.
- 10.3** The Proposals shall be submitted on-line in ISRO e-procurement portal before the time limit for bid submission specified in the Letter Inviting Bid.
- 10.4** The Proposal will be opened on the date and on the time specified in the Letter Inviting Bid or as soon thereafter as convenient. Proposal not received in time will not be considered.
- 10.5** Bidders shall set their quotations in firm figures and without variations/additions in the terms of the Proposal documents.

11. AMBIGUITY

Should there be any ambiguity or doubt as to the meaning of any of the tender clause/condition or if any further information is required, the matter shall be immediately brought to the notice of Sr. Head, Purchase & Stores of SDSC SHAR in writing.

12. BID EVALUATION

- 12.1 SDSC SHAR may open Part – I (UNPRICED TECHNO-COMMERCIAL PART OF THE BID) of the bid on the due date of opening subject to complying to the evaluation criteria given in form-III of section-C. Price Bids of technically and commercially acceptable offers shall be opened at a later date. In order to consider as valid experience, all the experience has to be supported with the technical details, supply invoice/completion certificate and purchase order as proofs.
- 12.2 SDSC SHAR reserves the right to reject any or all the Bids without assigning any reasons thereof.
- 12.3 ***Any bids/offers with price details in Techno-Commercial Offer (Part -I) shall be rejected.***
- 12.4 During evaluation, SDSC SHAR may request Bidder for any clarification on the bid OR additional documents.

- 12.5 SDSC SHAR seeks response to the given questionnaire for assimilating data which would be used for evaluating the capability of the supplier for executing the referred work. Hence, the supplier is requested to provide only genuine data and any discrepancy found at a later point of time may result in rejection of the supplier from purchase process. Furnishing of data cannot be construed as automatic qualification for participation in the tender. Questionnaire should be signed by a responsible and authorized person of the Company / Agency.
- 12.6 Bidder must provide the point by point compliance to the technical specifications along with deviations as per “Schedule of deviations” attached in Form - IV. The tender will be rejected, if the deviations are not acceptable to the Department.
- 12.7 The time schedule for completion is given in the Proposal document. Bidder is required to confirm the completion period unconditionally.
- 12.8 SDSC SHAR reserves the right to accept a bid other than a lowest and to accept or reject any bid in full or part without assigning any reasons. Such decisions by SDSC SHAR shall bear no liability whatsoever consequent upon such decision.
- 12.9 The Bidder, whose bid is accepted by SDSC SHAR, shall be issued a Letter of Intent (LOI) /Purchase Order (PO) to proceed with the work. Successful Bidder shall confirm acceptance by returning a signed copy of the LOI/PO.

13. CHANGES AND MODIFICATION TO SPECIFICATIONS, DRAWINGS AND QUALITATIVE / QUANTITATIVE REQUIREMENTS

- 13.1. Supplier shall obtain approval from SDSC SHAR before initiating the action for procurement of bought out items.
- 13.2. During the fabrication review, supplier has to carry out the mutually agreed modifications to meet the overall requirement.

14. TAXES AND DUTIES

14.1 GST, as per the HSN code of each individual intended item, will be applicable.

14.2 It is the responsibility of the contractor to issue the Tax Invoice strictly as per the format prescribed under the relevant applicable GST law (CGST Act/SGST Act/UTGST Act/IGST Act). Contractor to indicate the proper GSTN Registration/ HSN code in their tax invoices.

14.3 CGST/SGST/UTGST/IGST shall be paid at actuals against Tax Invoice but restricted to the amount and percentage in the contract.

14.4 GST details of SDSC SHAR are given below:

SLC RANGE FACILITIES – MODULAR CONSOLES, INSTRUMENTATION RACKS and CHAIRS

Designation: Purchase and stores officer, VALF Stores, SDSC SHAR

Contact no : 08623-226082

GSTIN : 33HYDF00385A1D7

15. DELIVERY SCHEDULE

- Supplier must furnish all the designs and drawings including codes and detailed specification documents within three weeks from the date of purchase order for Department’s clearance.
- Supplier must complete the fabrication of prototype within 4 weeks from the date of clearance of the drawings.
- Supplier must supply all the materials within 8 weeks after clearance of the prototype.
- The installation and commissioning must be completed within 4 weeks thereof.
- **Delivery Schedule: Split-up of overall schedule as follows**

S.No	Activity	Time Line
01	Release of purchase order	T0
02	Submission of Design Drawings for Approval (T1)	T1 = T0+ 3 Week
03	Drawings approval by Department (T2)	T2 = T1+ 2 Week
04	Prototype fabrication & Inspection (T3)	T3 = T2+ 4 Weeks
05	Prototype clearance (T4)	T4 = T3+ 1 week
06	Supply of all items with Prototype clearance (T5)	T5 = T4+ 8 Weeks
07	Installation & Commissioning after site clearance	2 Weeks from the date of issuing site clearance at SLC by SDSC SHAR.

Overall delivery schedule is **20 Weeks**.

16. LIQUIDATED DAMAGES

In the event of the Supplier failing to complete the work within the delivery period specified in the contract agreement, Department shall reserve the right to recover from the Supplier as liquidated damages, a sum of 0.5 percentage per week or part thereof of the undelivered portion of the total contract price of equipment or work. However, the total liquidated damages shall not exceed 10.0 percentage of the total Contract price.

17. INCOME TAX

Income tax at the prevailing rate as applicable and if applicable from time to time shall be deducted from the supplier's bills as per Income Tax Act and a certificate issued (TDS Certificate).

18. CUSTOMS DUTY

As per Customs notification No.05/2018 dated 25th January, 2018, ISRO is eligible only for partial exemption of Customs Duty (CD). The reduced rate of CD is 10.775% (CD@5%+Surcharge@10%+IGST@5%). Suppliers are requested to submit their bid by loading these elements wherever, it is applicable. In case of an order, we will issue CD exemption certificate to avail the exemption. The actual amount will be reimbursed against submission of documentary evidence.

In case bidder/vendor offering items considering customs duty exemption, they should also indicate the bill of materials and price, separately, with Customs Duty component and terms and conditions thereto.

19. RISK COVERAGE

The Supplier shall arrange comprehensive risk coverage at his own cost covering the value of equipment including transportation to the site from manufacturer's works, storage at site, erection, testing and commissioning at site. The period of such coverage shall be up to contractual completion period or any extension granted by Department thereof.

20. SECURITY DEPOSIT and PERFORMANCE BANK GUARANTEE

20.1 SECURITY DEPOSIT (SD)

3% value of the order shall be deposited with SDSC within 10 days from the date of the Purchase Order towards security deposit in the form of Bank Guarantee (BG)/ FDR/DD towards performance of the Contract valid till completion of the contract period plus 60 days towards claim period. (This will be returned by SDSC immediately on execution of the order satisfactorily as per order terms. If not, the amount will be forfeited).

20.2 PERFORMANCE BANK GUARANTEE (PBG):

Successful vendor has to submit a BG/DD/FDR in lieu of PBG from a Nationalized / Scheduled Bank for 3% of the order value after commissioning and acceptance of Manipulator system, valid till the completion of warranty period plus 60 days towards claim period.

20.3 COMBINED BG for PBG cum SD

In case, if parties are unable to provide two separate BGs, i.e., one for SD & one for PBG, they can submit a combined BG for SD & PBG for 3% of the Order value valid till the completion of total contractual obligation plus 60days. (i.e., Supply period plus warranty period plus 60 days).

20.4 Note: The bank guarantee shall be from a nationalized bank valid for the period mentioned above. No interest shall be payable on any bank guarantee. In case of breach of contract, the security deposit shall stand

forfeited in addition to other relief available to the Department under this contract.

21 PACKING AND FORWARDING

- a. The Supplier shall arrange to have all the material suitably packed as per the standards and as specified in the contract.
- b. All packing and transport charges, transit handling costs, transit risk coverage and transport fees of agents employed at the place of delivery or elsewhere, shall be deemed included in the price to be paid to the Supplier.

22 INSTALLATION & COMMISSIONING

- a. Supplier staff shall include adequate number of competent installation engineers with proven experience on similar works to supervise the installation works and sufficient skilled, unskilled and semiskilled labour to ensure completion of work in time.
- b. Supplier's installation staff/technicians shall arrive at site on date agreed by SDSC SHAR. Prior to proceeding to work, Supplier shall however, first ensure that required/sufficient part of his supply has arrived at site.
- c. Installation of equipment shall be planned in such a manner so as not to obstruct the work being done by other Suppliers and / or operating staff who may be present at that time.
- d. During installation, Department's quality team / their engineer will visit site from time to time with or without Supplier's engineer to establish conformity of the work with specification. Any deviations, deficiencies or evidence of unsatisfactory workmanship shall be corrected as instructed by Department.
- e. Supplier shall carry out work in a true professional manner and strictly adhere to the approved drawings. Any damage caused by Supplier during erection to new or existing building / environment shall be made good at no extra cost to Department.
- f. Supplier shall carry out the works in accordance with the specific instructions given on the approved drawings or as directed by Department. Equipment shall be erected in neat manner so that they are level, plumb, square and properly aligned and oriented.

23 WORK RULES AT SLC/SDSC-SHAR

- a. The work shall be carried out at SLC site on working days (Monday-Friday) only. The supplier shall obtain prior permission from the In-charge engineer for working late hours, weekends and holidays.
- b. Supplier shall follow the safety regulations / codes while working inside SLC/SDSC SHAR premises. The supplier shall take the

complete responsibility and necessary measures for the safety of the personnel deployed by him/her during all works including installation and commissioning activities at his own cost.

24 ACCOMMODATION

- a. Accommodation will not be provided by SDSC SHAR to supplier during installation and commissioning activities.
- b. Supplier shall make their own arrangement for accommodation, transportation & canteen facility for all his/her staff, technicians, labor & workers.

25 APPLICABLE LAW AND JURISDICTION

The laws of India shall govern this purchase order for the time being in force. The Courts of Andhra Pradesh, India only shall have jurisdiction to be with and decide any legal matters or disputes what so ever arising out of the purchase order.

26 FORCE MAJEURE

Should a part or whole work covered under this purchase order be delayed due to reasons of Force Majeure which shall include legal lockouts, strikes, riots, civil commotion, fire accident, quarantines, epidemic, natural calamities and embargoes the completion period for work, equipment referred to in this agreement shall be extended by a period not in excess of the duration of such Force Majeure. The occurrence shall be notified within reasonable time.

27 WARRANTY

The Contractor warrants that the item supplied shall be suitable for the purposes described in the specification document and shall be free from any defects in material or workmanship and shall be in accordance with applicable specifications, design requirements, and drawings. The Contractor shall provide warranty for all items supplied as part of this contract against any form of defects including painting for a period of **3 years from the date of acceptance by SDSC SHAR**. Any defects found either in materials or workmanship shall be made good by the Contractor at his/her own expense within the time specified by the Contract Manager.

28 SCHEDULE OF PRICE

- a. CONTRACT price shall include all costs of “For Fabrication, Supply, Installation and Commissioning of Modular Consoles for SLC”, shop inspection, prototype supply, packing, forwarding, transport to site, unloading, storage, all risk coverage, erection, installation, testing &

- evaluation and commissioning of the items including any other cost for proper and complete execution of the CONTRACT.
- b. Bidder shall quote the prices as per price bid format in ONLINE only in ISRO e-procurement portal as described in **Form-II price bid format of Section-C**.
 - c. The rate quoted shall be on FOR SLC basis.
 - d. The taxes applicable for supply and erection & commissioning shall be **indicated separately in** the price bid. If the offers submitted by the tenderers are silent on taxes, it will be presumed that quoted rates are inclusive of taxes & duties and no claim in this regard will be entertained later.
 - e. The price is firm and fixed and no variation on account of whatsoever reason is allowed after entering into contract.
 - f. Safe delivery of material at SLC site is bidder's responsibility at their cost.

29 MODE OF PAYMENT

Bidders shall submit the banker details and payments can be made through NEFT/RTGS/ECS through PFMS.

30 TERMS OF PAYMENTS

The following payment terms will be followed.

a. **Advance Payment:**

30% of supply value shall be paid as advance payment to the party against submission of bank guarantee for the advance amount.

b. **After receipt of items at SLC site:**

50% of supply value along with 100% tax portion against receipt of materials in good condition and satisfactory inspection of materials at SLC Site on pro rata basis.

c. **After commissioning (standalone) at SLC site:**

20% of supply cost and 100% of cost of commissioning charges (standalone) on pro rata basis after completion of Site acceptance testing and acceptance of the items by SDSC SHAR against submission of Performance bank guarantee of equal amount valid till warranty period plus 2 months.

d. **Penal interest:**

- In case of failure to execute the Order after drawing Advance, the seller should return the advance amount in full with interest at Bank lending rate plus 2% beyond delivery period and all BG/FDR/etc. shall be forfeited.
- In case of delay in execution of contractual obligations beyond delivery period, the seller is liable to pay interest on advance paid beyond the delivery period till the completion of scope of contract.

The rate of interest shall be loaded on option of advance by the bidder for arriving L1.

31.0 DISCLOSURE AND USE OF INFORMATION

- a. If the documents supplied by SDSC SHAR are marked **“Strictly Confidential”**, supplier shall take all necessary steps to ensure the same.
- b. Supplier shall guarantee that all information and data received during execution of Purchase Order from SDSC SHAR shall be classified as **“confidential”** within the meaning of the Official Secrets Act and will not be divulged to any third party without prior written permission of SDSC SHAR. All drawings & documents shall be returned after execution of work.
- c. No publicity of any kind whatsoever regarding this work shall be given without prior clearance from SDSC-SHAR.

32.0 CANCELLATION

32.1. GENERAL RULE

The Department shall have the right at any time to cancel a contract either wholly or in part by giving written notice by registered mail. From the time of receipt of the written notice, the Supplier shall undertake to observe the instructions of the Department as to the winding up of the contract both on his own part and on the part of his sub-suppliers.

32.2. WITHOUT FAULT OF SUPPLIER

In the case of cancellation of a contract by the Department without any fault of the Supplier, the Supplier shall on receipt of Department's instructions forthwith take the necessary steps to implement them. The period to be allowed to implement them shall be fixed by the Department after conclusion with the Supplier and, in general, shall not exceed three months. Subject to the Supplier confirming, Department shall take over from the Supplier at a fair and reasonable price all finished parts not yet delivered to the Department, all unused and undamaged material, bought-out components and articles in course of manufacture in the possession of the supplier and property obtained by or supplied to the Supplier for the performance of the contract, except such material, bought-out components and articles in course of manufacture as the supplier shall, with the agreement of the Department, elect to retain.

32.3. WITH FAULT OF SUPPLIER

The Department reserves the right, after full consideration of all relevant circumstances, including the observations of the supplier, to cancel a contract in any of the following circumstances.

- 32.3.1. In the event of the Supplier's failure to meet
 - (i) The Technical requirements of the Supplier.
 - (ii) The Progress and/or delivery requirements.

- 32.3.2. If the Supplier has not observed the provisions of the contract concerning the disclosure and use of information provided by the Department.
- 32.3.3. If the Supplier fails to comply with the provisions of the contract concerning the equipment, supplies and technical documents made available by the Department.
- 32.3.4. If the Supplier transfers his contract without the Department's authorization or concludes sub-contracts against the Department's explicit directives.
- 32.3.5. In the event that Supplier unjustifiably repudiates the Contract or fails to ship or dispatch all or part of the goods ordered for reasons other than those attributed to the Department's actions or as provided in the Force Majeure clause, the Department may, by giving an appropriate notice in writing to the Supplier, fix a Date of Essence by which the Supplier must complete the dispatch in full. If the Supplier fails to do so, the Department, in addition to his right to recover Liquidated Damages in terms of the Contract, shall also have the right to cancel this Contract and make substitute purchases from other sources. If the goods are in a partial state of fabrication, Department may have the fabrication completed by other means, in which event Supplier shall be liable to Department for the additional expenses incurred thereby, but shall not have any claim on savings, if any, in such cases. In the event of such cancellation, the Department shall unless otherwise specified in the contract, only pays.
- In the case of a fixed-cost contract for the supply of equipment or material. The contractual value of items delivered and accepted under the contract before receipt of notification of cancellation, or to be accepted under the special conditions of cancellation.
 - In the other cases. A fair and reasonable price in respect of such work as has been carried out prior to the receipt by the Supplier of notification of cancellation.

SECTION-B

TECHNICAL SPECIFICATIONS & FUNCTIONAL REQUIREMENTS of EXECUTIVE CONSOLES, EXECUTIVE CHAIRS, GALLERY CHAIRS RACKS and KVM SWITCHES

1. SPECIFICATIONS of MODULOR EXECUTIVE CONSOLES:

S. No	Part	Specifications	Details	Yes/No
1	Type	Open type. Schematic Layout for a console is given in the Clause 1.3 of Section-B (Schematic Layout Of A Modular Console) with dimension tolerance of $\pm 2\%$ for width and $\pm 1\%$ for height and depth.	<p>The dimension details of the consoles are as follows.</p> <p>1-bay console: 0.75m (Height) x 1.00m (Depth) x 0.9m (Width).</p> <p>2-bay console: 0.75m (Height) x 1.00m (Depth) x 1.55m (Width).</p> <p>3-bay console: 0.75m (Height) x 1.00m (Depth) x 2.3m (Width).</p> <p>6-bay console: 0.75m (Height) x 1.00m (Depth) x 4.55m (Width).</p> <ul style="list-style-type: none"> ➤ Consoles shall be constructed based on the above details. ➤ 2-bay, 3-bay and 6-bay consoles shall have seamless and aesthetically integrated working surface without any partitioning or discontinuity on the work surface. ➤ The consoles shall be designed as per 	

SLC RANGE FACILITIES – MODULAR CONSOLES, INSTRUMENTATION RACKS and CHAIRS

			standard design practice with adequate intermediate support, vertical support and metal reinforcement for improved structural integrity without any sagging.	
2	Structure & Base frame	Heavy duty extruded Aluminum profiles of IS 6063 / IS6105 (minimum thickness 3mm) T5/T6 sections with adjustment provision and extreme side Aesthetic Legs. The top and bottom supporting frames shall be made up of CRCA (minimum thickness 2mm). The Extrusions shall be duly powder coated with 40+ micron over all surfaces. All sheet metal parts must be finished with a durable, black, electrostatic powder coating with average application of 40 microns over all surfaces.	<ul style="list-style-type: none"> ➤ The structure shall be rigid enough to withstand BIFMA X5.5: 2014 tests. ➤ The structure shall allow easy assembly of Shutters, hinged shutters, gland plate and Monitor arms in extremely rigid manner. ➤ Provision for cable management system along the frame is required. ➤ Provision shall be made for fixing the equipment trays in the available slots with base frame including tray adjustment in vertical direction. ➤ The end frames shall have anti-tip extension. ➤ A weld-free structure shall be proposed to allow future extension and expansion 	
3	Work surface	Category-1: Made of Alumina Tri-Hydrate and acrylic solid surface of min. 12mm thickness	<ul style="list-style-type: none"> ➤ Top surface of table top/Work surface top shall be at height of 750 mm from the 	

SLC RANGE FACILITIES – MODULAR CONSOLES, INSTRUMENTATION RACKS and CHAIRS

		<p>supported on min. 25mm thick MDF base fitted firmly to body of the console.</p> <p>Category-2: Made of Alumina Tri-Hydrate and acrylic solid surface of min. 12mm thickness supported on min. 18mm thick MDF base fitted firmly to body of the console.</p> <p>Category-3: Work surface shall be constructed using a 25mm (min.) laminated MDF board, forming a rigid and durable composite work surface or 18mm high pressure laminate (HPL) compact board.</p>	<p>floor. The depth is all along the console width.</p> <ul style="list-style-type: none"> ➤ The top finish shall be fire retardant, water resistant, and scratch resistant and shall have high hardness with round corner. ➤ Provision to be made for keyboard under the work surface, and mouse on top of the work surface with concealed wiring below table top. ➤ High-density polyurethane moulded on industrial grade aluminium core to form 50mm deep tapered edge shall be installed at the front edge of worktop. In case of damage or wear, the edge shall be easily replaceable without opening or removing the worktop. 	
4	Decorative End Panels	<p>End panels of consoles shall complement the console design and shall be made up of the following materials as per the categories.</p> <p>Category-1: Alumina Tri-hydrate and acrylic resin material of minimum 12 mm thickness + 25mm laminated MDF board along with required metal</p>	<p>The structure shall be supported on formed legs (without any sharp edges & corners). Extreme end side leg shall have an anti-tip extension with durable, black, electrostatic powder coating including adjustable levelers.</p>	

SLC RANGE FACILITIES – MODULAR CONSOLES, INSTRUMENTATION RACKS and CHAIRS

		<p>structure to achieve the structural stability.</p> <p>Category-2: Shall be of 25+18mm MDF Board with Laminated Finish along with required metal structure to achieve the structural stability.</p> <p>Category-3: Shall be of 25mm MDF Board with Laminated Finish along with required metal structure to achieve the structural stability.</p>		
5	Rear & rear Shutters (Double Leaf on each door part)	<p>Category-1: Shutters shall be constructed using 18 mm (± 1 mm) laminated MDF board.</p> <p>Category-2: Shutters shall be constructed using 18 mm (± 1 mm) laminated MDF board.</p> <p>Category-3: Shutters shall be constructed using 2mm thick (min.) CRCA sheet with powder coated finish.</p>	<p>4 shutters in total. (2 in front side and 2 in rear).</p> <p>Doors shall be hinged inside with a keyed-alike locking lever latch, push mounted handle of standard makes.</p> <p>Louvers for ventilation on the bottom side of the doors.</p> <p>Provision shall be made for housing low noise exhaust fans of standard size with filters inside of door.</p>	
6	Base Plate (Bottom Plate)	CRCA / AL sheets (Minimum thickness 3mm).	Base plate must have provision for cable entries (of standard size) from bottom. These provisions to be made at minimum two locations at back side of each bay.	
7	19" rack mounting	The console shall have 19" standard rack-mounting provision (for 1U and 2U	Standard 19" Equipment will be positioned on the	

SLC RANGE FACILITIES – MODULAR CONSOLES, INSTRUMENTATION RACKS and CHAIRS

	provision	<p>equipment) with flush-recessed into the top surface of the control desk and inclined towards the operator at a defined angle for ergonomic access ensuring minimal projection above the working surface.</p> <p>The rack mounting plane shall be inclined between 10° to 20° towards the operator. The exact angle will be finalized during verification of design & drawings.</p>	<p>slope surface.</p> <p>Cutout size should be 19” Width and 1U/2U Height.</p> <p>A rigid subframe shall be provided below the desk to support the inclined rack preventing it from sagging and surface distortion.</p> <p>The inclined arrangement shall ensure clear visibility and ergonomic accessibility. There shall be no interference with operator workspace.</p> <p>The arrangement shall be seamless and aesthetically integrated with the working surface with smooth finished edges and no visible gaps or uneven joints.</p> <p>The cable routing shall follow the inclined geometry with clear rear access below desk.</p> <p>Dummy plates of 1U and, 2U size are to be supplied along with necessary accessories to cover the area in case equipment is not used.</p>	
10	CPU Trays (Bottom) (1 no. in each bay)	CRCA sheets (Minimum thickness 3mm) / AL sheets (minimum 4mm thickness With a load capacity of 50 kg	Provision for fixing the pullout tray with slides at the rear bottom side of the console for CPUs. There should not be any stopper at the edges which may lead to inadvertent switching OFF of CPU before taking it out.	
11	Upper Tray	One tray in each bay	Adjustable trays with	

SLC RANGE FACILITIES – MODULAR CONSOLES, INSTRUMENTATION RACKS and CHAIRS

			fixing arrangement in the slotted angles.	
12	Power Boards with spike suppressors	<p>2 no's of power boards (PDU) each with 6 no's of 6/16A 5 pin sockets in each bay. These boards shall have single control for all 6 sockets along with Indicator lamp and fuse for each board.</p> <p>A 2-bay console shall have 4 nos. of PDUs and a 3-bay console shall have 6 nos. and so on.</p>	The boards must be fitted to the vertical/Horizontal member of the base frame.	
13	Exhaust Fan	4", 230 V AC exhaust fan fitted on the interior side of each rear door of each bay of a console.	<p>The throw of hot air must be from inside the console to outside ambient. The fan to be covered by separate PVC filter so that the fan will not be seen from outside. The fan must be fitted to back door with power connection and miniature <i>ON/OFF switch</i>.</p> <p>The exhaust fan should be selected in such a way that its noise level is kept low enough to ensure a comfortable and safe working environment.</p>	
14	Light	LED Lamp	One LED lamp in each bay at suitable location with adequate luminous intensity inside the console.	
15	Cable Management	<p>2" by 2" cable management system with cover and provision to take out the cable from anywhere along the cable management system.</p> <p>Cable Management system should handle Network</p>	<p>The cable management system must be available along the vertical and horizontal members of the base frame of the console.</p> <p>All trays should be easily</p>	

SLC RANGE FACILITIES – MODULAR CONSOLES, INSTRUMENTATION RACKS and CHAIRS

		<p>Cables, Instrumentation cables and Power Cables separately.</p> <p>The Console System should provide a concealed cable routing system.</p>	<p>accessible during installation and maintenance. Terminal strips to terminate instrumentation cables and fixing arrangement for termination of LAN cables.</p> <p>Telephone RJ-11 socket module with - 1 No.</p> <p>Modular RJ-45 socket with 2 ports – 2 nos.</p>	
16	Power Earth strip & Instrumentation Earth strip	<p>Standard 3/4" or more Copper (Cu) strip for power earth and instrumentation earth separately along the rear and bottom side inside the console.</p>		
17	Mount and monitor arms for Monitors/ display	<p>Heavy duty pipes shall have swivel head. The monitor angle can be adjusted up/down/left/right and also vertical height can be adjusted as desired.</p> <p>Monitor arm assembly shall have auto lock, push & remove feature for quick release of VESA mounts and modular arm extensions for ease in maintenance and fixing of monitor</p>	<p>All the required cables shall be routed through the mount and distributed to all the monitors. The cables include both power and data.</p>	
18	Key board	<p>450 mm long and 280 mm depth standard type.</p>	<p>Keyboard shall be placed under the work surface.</p>	
19	Hardware	<p>All bolts must be of SS material to avoid rust due to environment. Remaining hardware shall be Nickel Plated.</p>	<p>The coating must protect the surface from corrosion.</p>	
20	Surface finish	<p>Good finish with round corner & standard polishing</p>	<p>The coating must protect the surface from corrosion.</p>	

SLC RANGE FACILITIES – MODULAR CONSOLES, INSTRUMENTATION RACKS and CHAIRS

			The surface shall be fire retardant, waterproof, scratch resistant and shall have high hardness	
21	Slat Wall	Shall be made of Aluminum alloy (IS:6063 /IS:6105-T5/T6) with minimum 2mm thickness	To be fixed at the back side of the console behind the 1U/2U 19” instrument rack for fixing monitor arm.	
22	General	The consoles shall be fully modular in design and construction.	Shall be ergonomically designed for operator comforts as per ISO11064 for operator to screen distance.	
24	ISRO Logo	<p>Metal plate of size 2”X2” with ISRO logo embossed on it.</p> <p>For category-1: ISRO logo shall be fixed to the Central portion of Panel with back light illumination.</p> <p>For category-2: ISRO logo shall be fixed to the Central portion of Panel with Stainless steel strip surrounding it.</p> <p>For category-3: ISRO logo shall be fixed to the Central portion of Panels.</p>	The logo must be pasted on the both side panels appropriately.	
25	Color of the console	Standard painted/polished color as per ergonomics of ISO11064	Color Will be confirmed at the time of manufacturing.	

1.1 PROVISIONS REQUIRED IN MODULAR CONSOLE FOR MOUNTING EQUIPMENT:

The console shall have the provisions for fixing the following equipment at identified locations within it. All the equipment listed below will be provided by Department. The vendor shall install/mount the equipment in the consoles at identified locations during installation at SLC site.

SLC RANGE FACILITIES – MODULAR CONSOLES, INSTRUMENTATION RACKS and CHAIRS

Sl. No	Unit	Specification	Location	Compliance (Yes/No)
1	CPU – 1 Nos	Tower model conventional CPU with a max height of 500 mm	Inside the cabinet and on the pull-out sliding type bottom tray.	
2	Monitor for computer/ TV Monitor	22” /24” Standard display	Modular arm VESA mounting. The view angle must be within the permissible limits as per the ergonomics.	
3	Intercom Unit -1 No’s	1U (45 mm) height with 200 mm depth	To be arranged in the 3U slant portion instrumentation rack of the console as per the drawing enclosed. Provision shall be made for easy removal/fixing of the units from the front side.	
4	Timing Unit- 1 No	1U (45 mm) height with 150 mm depth		
5	Video Selection Keyboard- 1 No	1 U (90 mm) height with 150 mm depth		
6	Panel switches	Customizable within the slanting portion.		
7	Filler Plates	1U(1 No’s) and 2U(1 No’s) height of 1 bay length with press type provision to be provided.	For filling the gaps in the case 1U/2U slant portion is not filled with equipment.	

Table- II: List of Equipment to be mounted in modular consoles.

2. Specific instructions

- After completion of configuration and design finalization, the vendor shall submit the design details, BOM, material specifications and all drawings, including 3D CAD files, for review and verification.
- The vendor shall submit quality assurance plan (QAP) detailing how all the essential parameters will be tested to confirm their compliances according to the drawing specifications.
- SDSC SHAR will conduct pre-production review for verification of dimensions, ergonomics, tolerances. The vendor shall present all required details during the review.
- Vendor shall produce and offer one set of items, prototype version, to SDSC SHAR for verification and analysis of fit, finish and functionality before start of production.
- A formal approval will be given to the vendor to go ahead with production of the items after verifying the sample items.

SLC RANGE FACILITIES – MODULAR CONSOLES, INSTRUMENTATION RACKS and CHAIRS

- All consoles will be inspected by SDSC SHAR engineers for verifying the specifications compliance.
- The consoles shall be dispatched to SLC site after inspection and clearance.
- The 6-bay console (mentioned in S.no:8 of “schedule of quantities” table) shall be constructed using three numbers of 2-bay consoles as per the indicative arrangement shown in figure-8. However, the configuration and layout shall be finalized in consultation with SDSC SHAR.
- Similarly, the arrangement for AC power sockets, earth strips and cable routing plan inside consoles shall be finalized in consultation with SDSC SHAR.
- Fasteners and nuts/bolts shall not be visible on any of the exposed surfaces of the consoles.
- Consoles shall be designed with hidden cable management provision. All the cables shall be routed/taken into the cabinet through desk leg. Desk legs shall have snap fit covers on the sides to access the wiring.
- All consoles shall have in-built rubber grommets for safety of cables and making it rodent proof.
- The electrical drawings shall be prepared as per the RFP specifications and submitted to the purchaser for review and clearance.

1.2 LIST OF CERTIFICATES REQUIRED TO BE SUBMITTED FOR CONSOLES:

The following certificates, valid throughout the contract period, shall be submitted for the consoles as mentioned below.

- Valid certificate of BIFMA X5.5 certificate from authorized agencies shall be submitted along with technical Bid.
- Console shall have stringent chemical emission standard. To ensure healthier air quality for the personnel working in the control room area, the proposed console shall be Greenguard/ Greenguard Gold certified. Valid Greenguard/ Greenguard Gold certificate shall be submitted along with the technical bid.
- Certification by govt. authorised laboratory for the control console for Seismic Zone 5 as per applicable IS standard.
- Certification for all exposed surfaces of control console that they meet fire safety standards as per ASTM E-84 class A standard test method for surface burning characteristics.
- Adhesion test: ISO 2409; Scratch test: IS 101-1964; Salt spray (FOG) test: ASTM B 117:600 hrs test certificates shall be submitted.
- Standard IS codes must be followed
 - For surface treatments and finishes – IS:13871, IS:1868, IS:5523, IS1573, IS:5905
 - For CRCA - IS:513
- Following certifications shall be submitted for the control console product along with the technical bid.
 - Product having FSC certification from last 2 years (i.e 2024 and 2025).
 - Product having seismic zone 4 certification from government approved agency.

SLC RANGE FACILITIES – MODULAR CONSOLES, INSTRUMENTATION RACKS and CHAIRS

- Product having RoHS certification.
- All exposed surfaces including MDF boards and shutters having ASTM E84 class A certification.
- OEM of offered product is ISO 9001:2015 certified.
- OEM of offered product is ISO 14001:2015 certified.
- OEM of offered product is ISO 18001:2007 certified or 45001:2018 certified.
- The product is ISO 11064 compliant.
- FSC certified wood product/boards should be used in the manufacturing of consoles and chairs, if used. Relevant documents shall be submitted along with the technical bid.
- Copy of test certification for the following ANSI/BIFMA test procedures performed by an independent testing laboratory or approved by a professional engineer:
 - Concentrated Functional Load Test
 - Distributed Functional Load Test
 - Concentrated Proof Load Test
 - Distributed Proof Load Test
 - Leg Strength Test
 - Stability under Vertical Load Test.

1.3 SCHEMATIC LAYOUT OF A MODULAR CONSOLE:

The schematic layout of a control console is shown below. The layout shall be used for reference purpose only. The vendor shall prepare the technically suitable design and 3D drawings for all three categories by incorporating the required improvements and modifications in the schematic layout w.r.t to the specifications and functional requirements given in this RFP document.

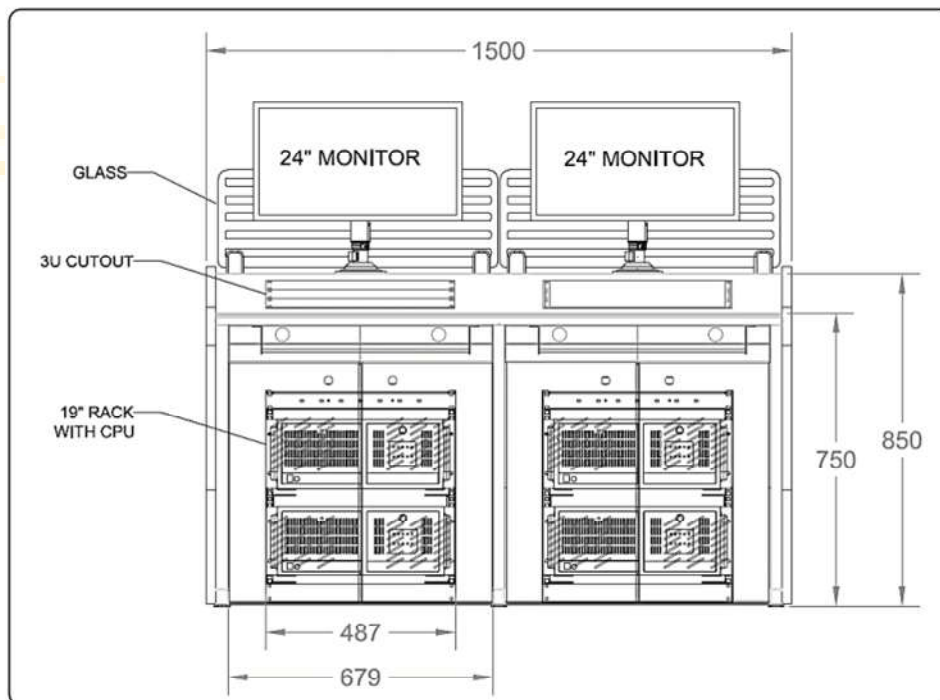

Figure-1 :: Schematic layout of the control console – Front View

SLC RANGE FACILITIES – MODULAR CONSOLES, INSTRUMENTATION RACKS and CHAIRS

Subsequently, the vendor shall submit all the design details, drawings, BOM and material specifications to SDSC SHAR for review and clearance. The corrections suggested during drawing approval stage shall be incorporated in the drawing without any cost implication.

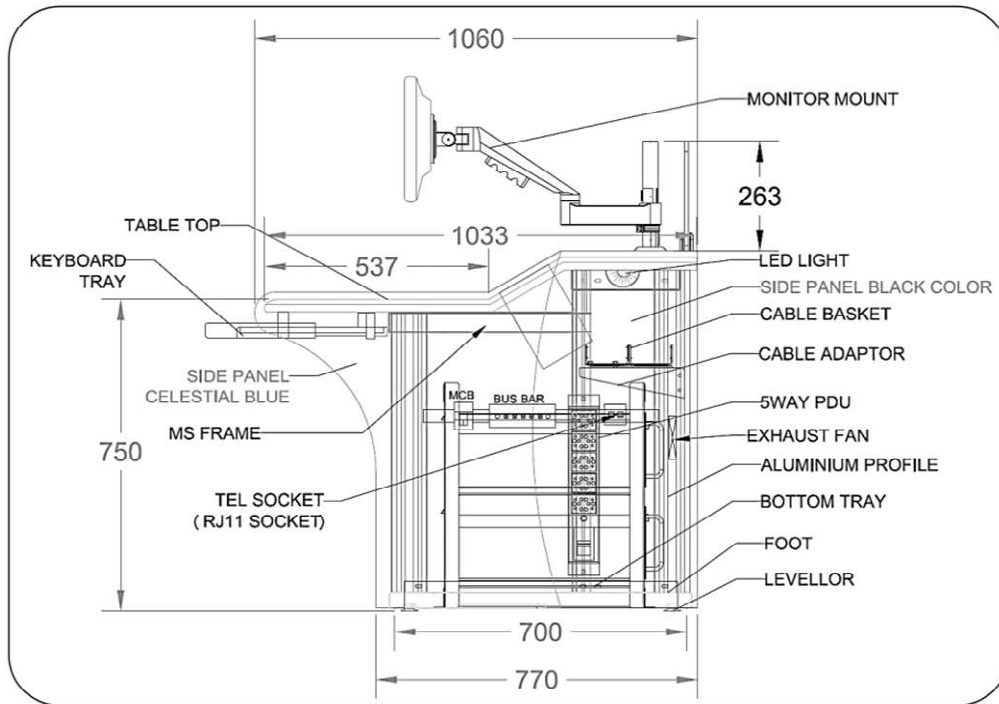

Figure-2 :: Schematic layout of the control console - Sectional view

Similarly, the schematic arrangement of 6-bay control console is shown below. The supplier shall propose a suitable arrangement for review and clearance by the purchaser.

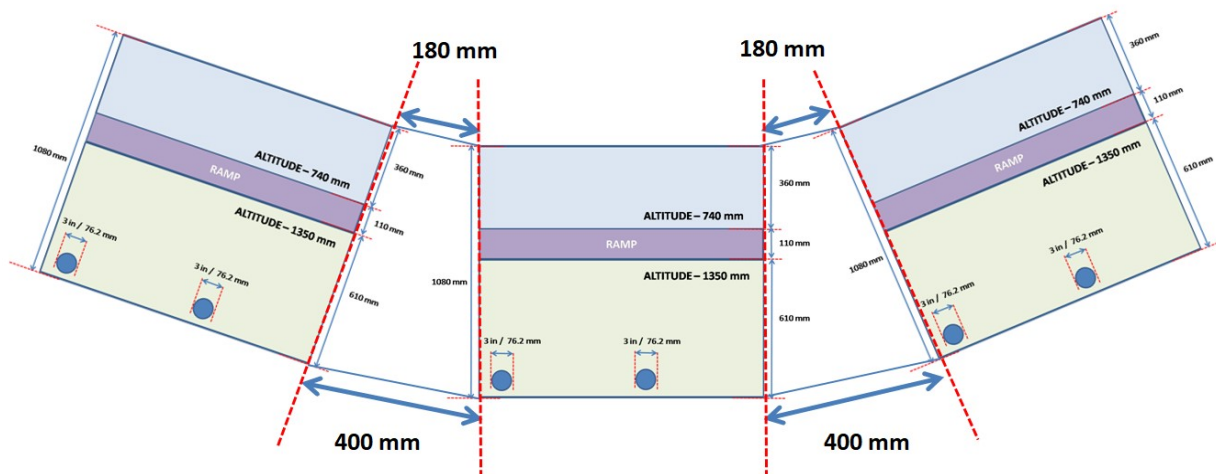

Figure-3 :: Top profile of 6-bay console arrangement

2. SPECIFICATIONS of EXECUTIVE CONSOLE CHAIR:

2.1 Material Specifications:

S.No	Material	Description	Compliance (Yes/No)
1	Frame	Heavy-duty steel or aluminum frame	
2	Pedestal Base	Standard 5-prong heavy-duty aluminum base. Twin Castor wheels 5 Nos. of 50mm Size	
3	Arm Material	<p>Category:1</p> <ul style="list-style-type: none"> ➤ Armrest shall be made up of Steel or Aluminum support frame for internal reinforcement and load-bearing capacity. ➤ Wide arm pads. 4D adjustable (height, width, depth, pivot) with soft PU padded leather top. ➤ The arm support shall have proper elbow support as per standard design practice (~90° to 110°) <p>Category:2</p> <ul style="list-style-type: none"> ➤ Wide arm pads. 3D adjustable (height, width, depth, pivot) with soft PU foam padded leather top. ➤ The arm support shall have proper elbow support as per standard design practice (~90° to 110°). <p>Category:3</p> <ul style="list-style-type: none"> ➤ Height adjustable. High density PU foam having long life. ➤ Hardness of the armrest padding shall be as per standard industrial requirement. 	
4	Seat Material	<p>Category:1</p> <ul style="list-style-type: none"> ➤ Cushioning: High density molded foam of 60mm to 80mm thickness. 	

SLC RANGE FACILITIES – MODULAR CONSOLES, INSTRUMENTATION RACKS and CHAIRS

		<ul style="list-style-type: none"> ➤ PU Foam Covered with PU leatherette of 0.8mm to 1.2mm thickness. ➤ Seat design features: <ul style="list-style-type: none"> • waterfall edge seat front. • Sweat resistance. • Color fastness:>grade 4. <p>Category:2</p> <ul style="list-style-type: none"> ➤ Cushioning: molded PU foam. ➤ Cover: Durable woven fabric material of 0.8mm to 1.2mm thickness. <p>Category:3</p> <ul style="list-style-type: none"> ➤ Cushioning: molded PU foam. ➤ Cover: Durable woven fabric material of 0.8mm to 1.2mm thickness. 	
5	Chair backrest material & support	<ul style="list-style-type: none"> ➤ Material: Mesh back with cushion headrest. ➤ Must support the lower spine (lumbar region) with height and depth adjustment. ➤ Backrest tilt range: 90° to 125°. 	
6	Density of PU foam used in seat/ backrest KG/m ³ (+/- 3)	50	
7	Material of Fabric Back Cover/ Backrest/Seat cover	Mesh back	
8	Color	Black	

2.2 General Specifications:

S.No	Specification	Description	Compliance (Yes/No)
a.	Chair Type	Advanced Bio Synchronic	
b.	Till Tension Adjustment	Yes	
c.	Height Adjustment and tolerance	Gas-lift up to 100mm ± 5mm	
d.	Type of backrest support	Backrest symmetrical lumber support	

SLC RANGE FACILITIES – MODULAR CONSOLES, INSTRUMENTATION RACKS and CHAIRS

e.	Arm Type	Adjustable	
f.	Back type	Height adjustable; Backrest is made of two pieces injection moulded frame	
g.	Seat	Curved; Optional sliding type	
h.	Locking mechanism	Yes; Tilt limiter	
i.	Number of arm Movement	2 (up & down)	
j.	Overall Chair Height $\pm 15\text{mm}$	950 millimeters	
k.	Backrest Height $\pm 15\text{mm}$	600 millimeters	
l.	Backrest Width $\pm 10\text{mm}$	480 millimeters	
m.	Seat Height $\pm 25\text{mm}$	500 Millimeter	
n.	Seat Width $\pm 10\text{mm}$	500 Millimeter	
o.	Seat Depth $\pm 10\text{mm}$	500 Millimeter	
p.	Thickness of MS Plate Joining the under structure with Seat	2 Millimeter	
q.	Pedestal Size (Diameter) $\pm 10\text{mm}$	650 mm	
r.	Thickness of Polyurethane Foam used in Seat/Backrest ($\pm 2\text{ mm}$)	55 mm	
s.	Load capacity	150kg minimum.	
t.	Certifications	Green guard, Indoor Air Quality,	

***Note:** Dimensional tolerance of $\pm 1\text{cm}$ is acceptable.

2.3 Reference Drawing:

The reference drawing of executive chairs is given below for indicative purpose.

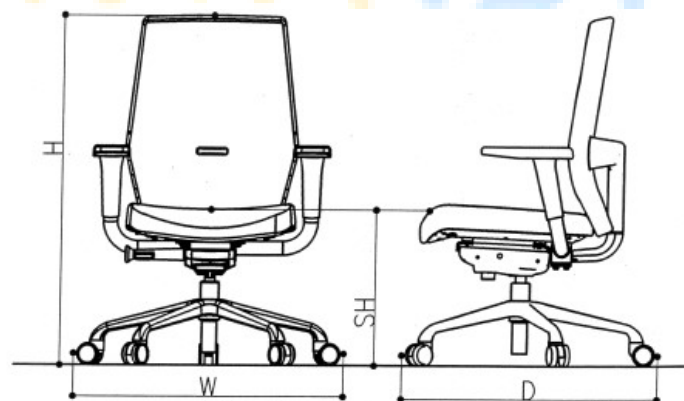

WIDTH (W) : 76.1 CM.
 DEPTH (D) : 76.1 CM.
 HEIGHT (H) : 96.5–114.0 CM.
 SEAT HEIGHT (SH) : 43.1–53.1 CM.

THESE DIMENSIONS ARE PRODUCT OUT OF OUT DIMENSIONS & VARIATIONS WITHIN $\pm 1.0\text{ CM}$ ARE NORMAL.

Figure 4 : Reference drawing of executive console

2.4 LIST OF CERTIFICATES REQUIRED TO BE SUBMITTED FOR EXECUTIVE CHAIRS:

- Test reports to be furnished along with the bid to buyer
- Product having BIFMA X5.5 certification
- OEM of offered product is ISO 9001:2015 certified
- OEM of offered product is ISO 14001:2015 certified
- OEM of offered product is ISO 18001:2007 certified (OR) 45001:2018 certified.
- Green guard certification
- AIOTA certification
- Fire safety compliance

3. SPECIFICATIONS of VIP/VVIP GALLERY CHAIRS:

Description	Specifications	Compliance
Mounting Leg	Made of CRMS tubular MS sheet metal component MIG welded to give sufficient rigidity and strength	
Main frame	Made of Sq. 25 X 2 mm. thick M.S ERW tubes, 55 x 35 x 5.00 mm. M.S pressed angles, 4.00 mm thick M.S Gussets which support the mounting legs as well as the seat structures.	
Seat base support	Made of pressed M.S sheet metal with provision for mounting system which facilitates easy removal. The support should have provision for retaining the upholstery and care be taken to avoid damage to upholstery.	
Back rest frame	The backrest frame should be of M.S ERW rectangular tube of size 30 x 20 x 1.60 mm, with suitable connecting tube and other reinforcement to avoid buckling. The frame should have brackets to enable mounting as well as assembly of back cover.	
Retractable arm rests	Integral skin molded poly urethane (PU) foam pad of size 80 mm. width with same color as upholstered in seat base and back rest fitted on pressed CRCA (cold rolled closely annealed extra deep draw steel) arm rest. It is finished by silver cloud color paint.	

SLC RANGE FACILITIES – MODULAR CONSOLES, INSTRUMENTATION RACKS and CHAIRS

<p>Seat Base and Back Rest cushion assembly</p>	<p>Seat Base and back rest cushion assembly- Ergonomically contoured CFC (chloro fluoro carbon) free moulded Poly urethane foam fire retardant with optimum hardness and bucket shape as follows:</p> <ul style="list-style-type: none"> a. Hardness : <ul style="list-style-type: none"> ➤ Seat Base: 12 – 18 Kgf. ➤ Back rest : 11 – 17 Kgf b. Density : 45 – 55 Kg / cu. mtr. c. Compression set test: 13% maximum. d. Resilience : 40 – 60 % e. Elongation gap: 80 % minimum. f. Tensile strength: 0.65 Kg./Sq. cm g. Flammability test: as per IS:3795/1976(E) or FMVSS 302 or IS:15061 – 2002 Annexure 1 for horizontal Burning rate specification. 	
<p>Upholstery</p>	<p>Fire retardant Pulsh Jacquard type high quality fabric laminated with 4 mm. U-foam and 12 mm. anti bacterial U-foam pad stitched. Head rest upholstery cover should be provided with suitable Velcro. The color of the fabric will be decided at the time of ordering.</p>	
<p>Head rest cover</p>	<p>The head rest provided with upholstery cover made of smooth rexine cloth in double layer and PVC strip edge with elastic straps.</p>	
<p>Back cover</p>	<p>The back cover is made of Injection molded PPCP of 2.5 mm. thick and match with the back rest contour.</p>	
<p>Side cover</p>	<p>Injection molded PPCP of 2.5 mm. thick with silver grey color. The side cover be provided at both sides.</p>	
<p>Over all width of chair</p>	<p>Single seater assembly with 650 mm over all width.</p>	
<p>Over all height of chair</p>	<p>1090 mm. approx.</p>	
<p>Over all depth of the chair</p>	<p>780 mm. approx.</p>	

SLC RANGE FACILITIES – MODULAR CONSOLES, INSTRUMENTATION RACKS and CHAIRS

Structure	The materials used for construction of frame structure shall confirm to IS standards: M.S tubular components – ERW 1 un-annealed / annealed as per IS: 3074. MS Sheet metal Components – IS 513, IS:1079, O & D classes. All metal parts Exposed to air to be Zinc phosphated and black powder coated to give a dry film thickness of 40 microns minimum.	
Fire retardant fabric	Fabric to comply fire retardant specification as per IS 15061:2002 Annexure A – Horizontal burning rate	
Load capacity	150kg minimum.	

3.2 Reference Drawing:

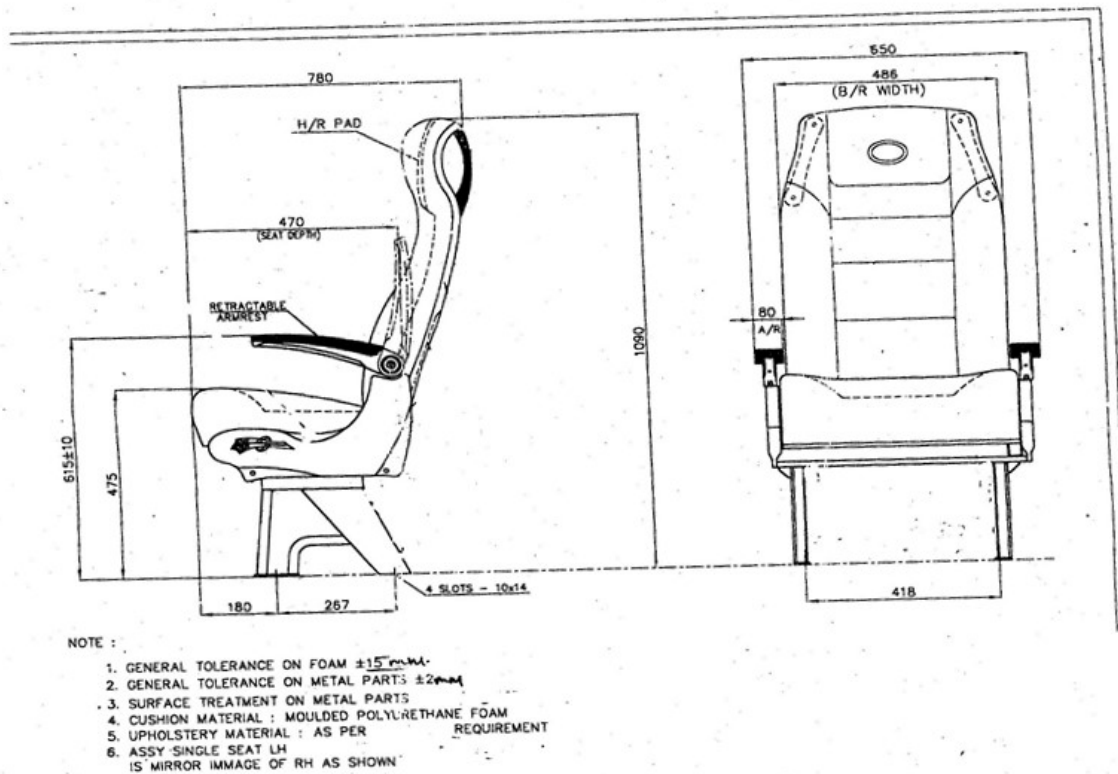

Figure 5 . Reference Drawing of Gallery Chairs

SLC RANGE FACILITIES – MODULAR CONSOLES, INSTRUMENTATION RACKS and CHAIRS

4. SPECIFICATIONS of 4/8 PORT IP BASED LCD KVM:

Description		Compliance
Local	1 (Share Remote Bus)	
Remote	1	
Direct (port)	4/8	
Maximum	128 (via Daisy-chain)	
Port Selection	OSD, Hotkey, Pushbutton	
External Console Ports	1 x SPHD Male or 1XDVI/HDMI/VGA	
External Mouse Port	1 x USB Type-A Female	
USB Port	1 x USB Type-A Female	
KVM Ports	4/8 x SPHD Female or 4/8XRJ45	
Daisy Chain Ports	1 x RJ45/DB-25 Male	
Firmware Upgrade	1 x RJ-11 Female/USB	
LAN Ports	1 x RJ-45 Female	
Power	1 x IEC 60320/C14	
Port Selection	2 x Pushbuttons or using Any Hot Keys on Keyboard	
Station Selection	2 x Pushbuttons or using Any Hot Keys on Keyboard	
Reset	1 x Semi-recessed Pushbutton	
LCD On/Off	1 x LED Pushbutton	
Online	4/8	
Port ID	(1 x 2-digit, 7-segment) or (Display on KVM or LCD Screen)	
10/100 Mbps	1	
Power	1	
Lock	1 x Num Lock	
	1 x Caps Lock	
	1 x Scroll Lock	
Display		

SLC RANGE FACILITIES – MODULAR CONSOLES, INSTRUMENTATION RACKS and CHAIRS

LCD Module	17 or 19" TFT-LCD	
Resolution	1280 x 1024 @75 Hz or 1920X1080@60Hz	
Pixel Pitch	0.264 mm x 0.264 mm	
Response time	5 msec.	
Viewing Angle	170° (H), 160° (V)	
Support Color	16.7M colors	
Contrast Ratio	1000:01:00	
Luminance	250 cd/m ²	
Keyboard / Mouse	PS/2, USB	
Scan Interval	1-255 sec.	
Maximum Input Power Rating	100-240V AC, 50-60Hz, 1A	
Operating Temperature	0-50°C	
Storage Temperature	-20-60°C	
Humidity	0-80% RH, Non-condensing	



5. FLOOR MOUNT NETWORK/INSTRUMENTATION RACK OF 42U HEIGHT:

5.1 SPECIFICATIONS:

S.No	Description	Compliance
1	Base Frame: Steel	
2	Dimensions : 42U Height, 600 mm Width, 800 mm Depth – Qty: 23 nos. 42U Height, 800 mm Width, 1000 mm Depth – Qty: 29 nos.	
3	Front & rear doors, top, bottom & side covers: ≥1.0mm thick CRCA sheet with standard Powder coating	
4	Top cover: Bolted/ welded to frame with Cable entry/ exit cut outs and Fan module mount provision	
5	Bottom cover: Bolted/ welded to frame with Cable entry/ exit cut outs.	
6	Front Door: single Lockable, 66% (approximately) Honeycomb perforated door frame to provide the maximum airflow and with PU gasket. The door shall have hinges.	
7	Rear Door: single Lockable, Honeycomb perforated vertical half split door frames with hinges.	
8	Detachable vented (louvered) side panels/ doors with slam latch & lockable.	
9	19” Mounting angle: Formed steel – 4 no’s, adjustable; with punched 10 mm Sq. Slots.	
10	Numbered U marking on both front and rear sides. U markings shall be screen printed.	
11	Vertical adopter kit/ a suitable cable management system with 90mm loop - at both sides on front & rear of the Rack with 4 no’s of Cable entry provision.	
12	Standard Finish: Powder coated.	
13	Colour: RAIL code 7037- Gray	
14	Mounting: Castor wheels (4 nos - 2 with brakes & 2 without brakes) and Levelers (4 nos)	
15	Static load: Min. 500 Kg with Casters; Min. 1000 Kg with Levelers	
16	Accessories: Suitable / Compatible accessories for each Rack, shall include the following: a) 4-Fan Module – 1no b) 1Ph, 230V (3.6KVA) vertical PDU with 15 X 5A Indian Plug type & 16A MCB and indicator – 1no. c) 19” Horizontal PDU with 6 X 5A Indian Plug type & with 16A MCB and indicator – 1no. d) Cable management brackets from top to bottom on both sides.	

SLC RANGE FACILITIES – MODULAR CONSOLES, INSTRUMENTATION RACKS and CHAIRS

	<ul style="list-style-type: none">e) Captive mounting screws – 5 packets, each packet consisting of 10 sets of screws.f) Vertical Copper Earthing continuity kit (3 mm thick, 19 mm wide, 42U) – 1 no.g) 4-Core AC Power Cable – 15m length as per the following specifications.<ul style="list-style-type: none">➤ 4-Core X 6 Sq.mm Copper conductor Power Cable from any reputed brand conforming to IS: 1554.h) Angle pair suitable for the Rack – 8 pairs (16 nos)i) Fixed shelf – perforated, suitable for the Rack – 1 noj) 19”, 2U Tool Drawer with sliding mechanism – 1 no.k) Front mount Shelf’s / Cantilever shelf type-2 – perforated, 2U, 400mm Depth – 1 nol) Front mount Shelf’s / Cantilever shelf type-2 – perforated, 1U, 400mm Depth – 1 nom) Aluminum blank/ filler panels (10 SWG) size 19”, 7U with hinge fixed at one end – 2 no’sn) Aluminum blank/ filler panels (10 SWG) size 19”, 3U (without hinge) – 1 noo) Aluminum blank/ filler panels (10 SWG) size 19”, 2U (without hinge) – 2 nop) Aluminum blank/ filler panels (10 SWG) size 19”, 1U (without hinge) – 2 no.q) The tolerance on the dimensions: ±5mm.	
--	--	--

5.2 GENERAL CONDITIONS FOR 42U RACKS:

- a. The rack should be compliant to EIA-310 standard hole-mounting pattern with U marking on the front and rear of each rail for ease of installation.
- b. The base frame of the rack shall have the provision of grounding points to ground each rack to the identified ground.
- c. All rack components like doors, side panel, top panel, 19” rail, and PDU bracket shall be directly connected to the base frame so as to eliminate any separate grounding requirement.
- d. Front door shall have Single point key lock and Swing handle. Rear door shall have single point key lock and Swing handle.
- e. Dimension of Side panels shall be as per the quantity requirement. i.e. 29 racks shall have the side panels of 1000mm width and 23 racks shall have the side panels of 800mm.
- f. Racks shall be durable & strong that can support at least 1300kg weight static load.
- g. Roof of the rack shall be removable from the exterior of the enclosure with PU gasket.
- h. Doors shall easily be removable with minimum efforts during maintenance.

SECTION-C: FORMATS

All the forms in this section shall be submitted in the relevant bids (Techno-Commercial bid and Price bid) without fail. It shall be ensured that the price information (form-II of Section-C) is included only in the price bid. Price information shall not be revealed in Techno-Commercial bid.

Form I: OVERALL COMPLIANCE STATEMENT FORM

S. No	SDSC (Department) Requirement	Compliance and details
1	<p>Scope:</p> <ul style="list-style-type: none"> ➤ Supply of modular consoles, executive chairs, gallery chairs, KVMs and racks as per tender specification: ➤ Submission of technical datasheets/specifications including Make and model of all the items offered along with Compliance statement. 	
2	<p>Configuration and Design:</p> <p>Design details of consoles, chairs along with 3D drawings, BoM, material specifications shall be submitted for review and approval by SDSC SHAR.</p>	
3	<p>Bidder shall submit compliance to Bidder Qualification Criteria, Evaluation criteria formats and other details sought as per Form-I, Form-III, Form-IV, Form-V, Form-VI, Form-VII and Form-VIII providing all mandatory information along with official signature and stamp of the firm.</p>	
4	<p>Testing & Inspection:</p> <p>The seller shall prepare and submit a detailed Quality Assurance Plan (QAP) document to SDSC SHAR for review and clearance. The entire testing and acceptance of all items will be done as per the approved QAP document as mentioned below.</p> <ol style="list-style-type: none"> 1) Inspection and clearance of Prototype console, chair and rack. 2) Acceptance testing of all deliverables (both Factory Acceptance Test and Site Acceptance Test) 3) Subsequent to satisfactory completion of SAT, the delivered items will be accepted after review & clearance from CLIP inspection panel of SDSC SHAR. 	
5.	<p>Warranty: As per standard warranty period of 3 years from date of acceptance of materials at SLC site.</p>	
6.	<p>General Terms and Conditions: All the points as given in Section-A: commercial Terms & Conditions are complied.</p>	

Authorized Signatory's Signature:

Authorized Signatory's Name and Designation:

SLC RANGE FACILITIES – MODULAR CONSOLES, INSTRUMENTATION RACKS and CHAIRS

Form II. PRICE BID FORMAT

S. No	Item Description		Qty	Units	Unit Cost (Rs)	Applicable Taxes	Total cost Rs.
1	Fabrication and Supply of 3-Bay Modular control console as per the specifications-1 of section-B of this RFP document.	Category -1	18	Nos.	Price	GST	Total Price
2	Fabrication and Supply of 3-Bay Modular control console as per the specifications-1 of section-B of this RFP document.	Category-2	22	Nos.	Price	GST	Total Price
3	Fabrication and Supply of 2-Bay Modular control console as per the specifications-1 of section-B of this RFP document.		8	Nos.	Price	GST	Total Price
4	Fabrication and Supply of 6-Bay Modular control console as per the specifications-1 of section-B of this RFP document.		1	Nos.	Price	GST	Total Price
5	Fabrication and Supply of 1-Bay Modular control console as per the specifications of the tender		2	Nos.	Price	GST	Total Price
6	Fabrication and Supply of 3-Bay Modular control console as per the specifications-1 of section-B of this RFP document.	Category-3	10	Nos.	Price	GST	Total Price
7	Supply of Executive chairs (24x7 control room chair) for control console as per the specifications-2 of section-B of this RFP document.	Category -1	90	Nos.	Price	GST	Total Price
8	Supply of Executive chairs (24x7 control room chair) for control console as per the specifications-2 of section-B of this RFP document.	Category -2	82	Nos.	Price	GST	Total Price
9	Supply of Executive chairs (24x7 control room chair) for control console as per the specifications-2 of section-B of this RFP document.	Category -3	21	Nos.	Price	GST	Total Price
10	Supply of VIP/VVIP Gallery chairs as per the specifications-3 of section-B of this RFP document.		109	Nos.	Price	GST	Total Price

SLC RANGE FACILITIES – MODULAR CONSOLES, INSTRUMENTATION RACKS and CHAIRS

11	Supply of 8-port KVM Switch per the specifications-4 of section-B of this RFP document.	9	Nos.	Price	GST	Total Price
12	Supply of 4-port KVM Switch per the specifications-4 of section-B of this RFP document.	2	Nos.	Price	GST	Total Price
13	Supply of 42U Network/Instrumentation rack (600 x 800) per the specifications-5 of this RFP document.	23	Nos.	Price	GST	Total Price
14	Supply of 42U Network/Instrumentation rack (800 x 1000) per the specifications-5 of this RFP document.	29	Nos.	Price	GST	Total Price
15	Installation & Commissioning at SLC site	1	lot	Price	GST	Total Price

Place:

Date:

Authorized Signatory's Signature:

Authorized Signatory's Name and Designation:

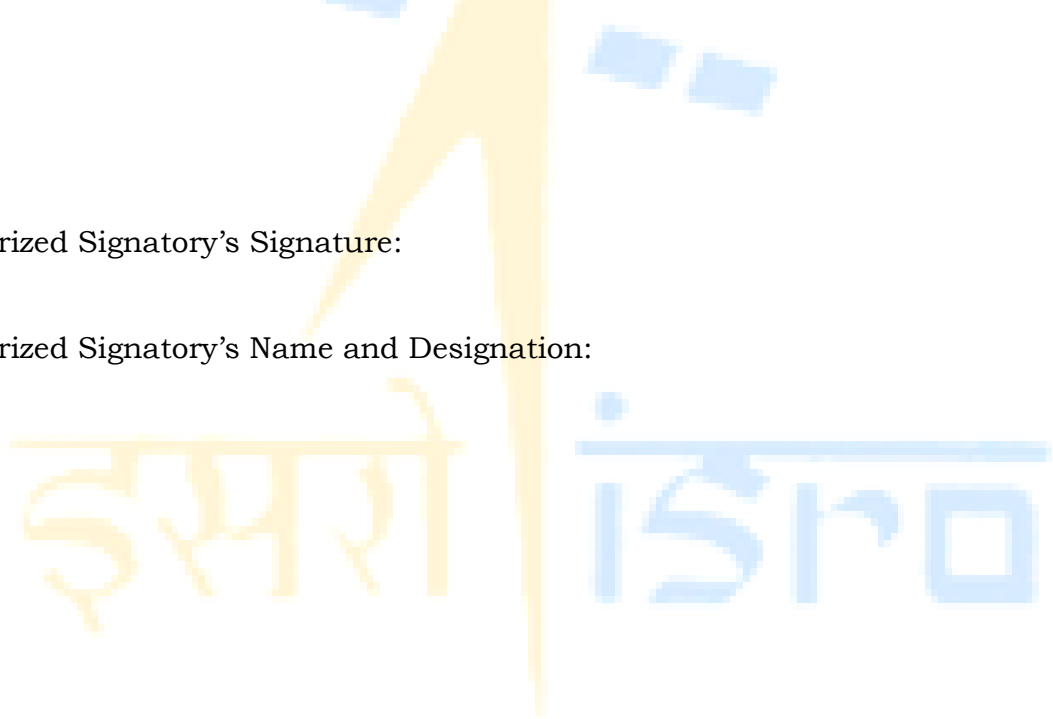

Form III. EVALUATION CRITERIA.

S.No	Description	Compliance
1.	In respect of Two-Bid system, the techno-commercial bid submitted by the Bidder will be evaluated by SDSC SHAR with reference to the technical specifications as mentioned in section-B of this RFP document. The compliance of techno-commercial bid would be determined on the basis of the parameters specified in the RFP. The Price Bids of only those bidders, whose technical bids clear the technical evaluation and are technically qualified, will be opened for further evaluation.	
2.	During evaluation, SDSC SHAR may request Bidder for any clarification and additional documents related to the bid. If required, SDSC SHAR team may visit Bidder's place for evaluating Bidder's overall capability in manufacturing, testing and supplying of control consoles and chairs.	
3.	During such visit, Bidder must demonstrate technical capability, manufacturing capability, quality control process, ergonomics and design standards to SDSC SHAR team. Bidder shall provide suitable clarifications and justifications to all the technical queries raised by SDSC SHAR team.	
4.	Bidder must provide the point-by-point compliance to all the specifications. Deviations, if any, shall be clearly brought out as per Form-IV "Deviations And Exceptions List". The tender can be rejected if the deviations are not acceptable to SDSC SHAR.	
5.	Performance of Bidder on similar nature of works executed/ under execution shall be taken into consideration before selecting the Bidder for opening his/her price bid.	
6.	The time schedule for completion is given in the Proposal document. Bidder is required to confirm the completion period unconditionally.	
7.	SDSC SHAR reserves the right to reject any bid if technically/commercially not meeting the requirement/terms & conditions. Such decisions by the SDSC SHAR shall bear no liability whatsoever consequent upon such decision.	
8.	Total price inclusive of all taxes, duties, shall be considered for arriving the lowest offer (L1 offer) and awarding the contract as per the purchase procedures of DOS.	
9.	If there is a discrepancy between the unit price and the total price that is obtained by multiplying the unit price and quantity, the unit price will prevail and the total price will be corrected. If there is a discrepancy between words and figures, the amount in words will prevail for calculation of price.	
10.	Department reserves the right to inspect the contractor shop floor/premises for evaluation, if required. After evaluating the contractor, decision of the Department is final.	

Authorized Signatory's Signature:

Authorized Signatory's Name and Designation:

Form IV. DEVIATIONS AND EXCEPTIONS LIST

S. No	REFERENCE IN SPECIFICATION		DEPT SPECIFICATION	OFFERED SPECIFICATION	DEVIATION
	PAGE NO	CLAUSE NO			

NOTE:

- Only deviations are to be written in the above form.
- Any deviations taken by the Bidder to the stipulations of the Proposal document shall be brought out strictly as per this format and enclosed along with the bid.
- Any deviations not brought out in this Pro-forma and written elsewhere (other than technical specifications compliance table) in the Proposal document shall not be recognized and the same is treated as null and void.
- Any willful attempt by the Bidders to camouflage the deviations by giving them in the covering letter or in any other documents that are enclosed may render the Bid itself non-responsive.

Authorized Signatory's Signature:

Authorized Signatory's Name and Designation:

SEAL OF THE COMPANY DATE:

Form V – BIDDER GENERAL INFORMATION FORM

Sl. No	Information Sought	Details to be Furnished
1	Name of the Company/Firm	
2	Date of Incorporation (Registration Number and Registering Authority)	
3	Legal Status of the Company in India & Nature of Business in India (Public Ltd Company / Private partnership firm)	
4	Address of the Registered Corporate office in India	
5	Address of the registered Regional or Branch Office in India	
6	Date of Commencement of Business	
7	Name & e-mail ID, phone number, Fax of the Contact person	Name: Designation: Phone: Mobile: Fax: Email:
8	Web-Site of the Company/Firm	

Authorized Signatory's Signature:

Authorized Signatory's Name and Designation:

SEAL OF THE COMPANY DATE:

FORM VI - EXPERIENCE IN DOING SIMILAR WORKS IN INDIA

Sl. No	Description	Details	Page Number reference in the proposal	Page No reference in the respective work order/ Contract
1.	Name of the Project			
2.	Project done by the Bidder			
3.	Name of the client company			
4.	Type of client (Whether any kind of State / Central Govt or Private)			
5.	Similar works			
6.	Status of the Project			
7.	Value of the Project			
8.	Project location with contact details of the company/ organization			
9.	Project Scope			

Note: For each Project, separate Form-VI has to be submitted with copy of Purchase Orders, Project completion reports and satisfactory performance report from the customer.

Authorized Signatory's Signature:

Authorized Signatory's Name and Designation:

SEAL OF THE COMPANY DATE:

Form VII – Letter of Authorization

To

The Senior Purchase Officer,
SDSC SHAR.

Sir,

Sub: Letter of Authorization for signing and submission of this bid –
Reg.

M/s. _____ is herewith authorizing
Mr./Ms..... for preparing this
bid and signing wherever required in this RFP document based on resolution
passed and approved by this company and or consortium firms.

I/We _____ certify that the company is entirely
responsible for any mistakes / disputes arising for submission of this tender. In
case of violation of any of the conditions above, I/We_____ understand
that I/ We are liable to be terminated at any stage and blacklisted.

Place:

Date:

Authorized Signatory's Signature:

Authorized Signatory's Name and Designation:

Form-VIII Compliance Statement Form

Sl. No.	Description	Bidder's compliance (Yes/No)
General terms		
1.	Confirm that the entire scope of work as given in the tender specification is considered for quoting the price. Deviations shall be brought out separately as per Form-VI. In the absence of deviations list, it will be presumed that all the specifications given are adhered to.	
2.	PBG at 3% of the value of the Purchase Order shall be submitted through bank guarantee from any of the Scheduled /Nationalized Banks executed on non-judicial stamp paper of appropriate value within 15 days from the date of acceptance, and shall be valid for a period of sixty days beyond the date for completion of warranty period.	
3.	Bidder shall submit security deposit, within 15 days of Order Acknowledgement, for 3% of the total order value. Security Deposit shall be obtained through Bank Guarantee or fixed deposit receipt from any of the Scheduled / Nationalized Banks executed on non-judicial stamp paper of appropriate value, and shall be valid for a period of sixty days beyond the date of acceptance.	
4.	If the supplies are not made by the end of delivery period, liquidated damage will be levied @ 0.5 % per week or part here of subject to a maximum of 10% of total order value.	
5.	The vendor shall fabricate, test and supply all items mentioned in this RFP document after submitting relevant technical details & drawings, BoM details to SDSC SHAR and obtaining approvals from SDSC SHAR.	
6.	After completing the fabrication and testing of the items, the vendor shall intimate the purchaser, SDSC SHAR, regarding its readiness for inspection at vendor's site.	
7.	SDSC SHAR deserves the right to visit the vendor's site and carry out inspection of the fabrication/realization of the intended items w.r.t the approved drawings. The vendor shall incorporate the deviations/corrections suggested during the inspection.	
8.	The vendor shall supply all the items (control consoles,	

SLC RANGE FACILITIES – MODULAR CONSOLES, INSTRUMENTATION RACKS and CHAIRS

	racks, KVMs and chairs) to SLC site, Kulasekarapatnam after obtaining clearance from SDSC SHAR.	
9.	All the supplied items need to be erected in various technical facilities/buildings within at SLC site, as per the requirements given by SDSC SHAR.	
10.	The vendor shall take care of all material handling tools, assembly & fastening tools, cable management & termination tools, measuring & alignment tools and safety gears required during installation of the supplied items at SLC.	
11.	Payment terms : As mentioned in clause 30 of section-A of this document (Payment terms clause)	
12.	The vendor share unpriced copies of all Purchase Orders of bought out components to SDSC SHAR after placement of orders.	
13.	Bidder shall submit the project status report every 15 days mentioning the status of fabrication activity w.r.t. drawing numbers and actual photo graphs.	
14.	Offer shall be valid for 120 days from the due date for submission of the Bid.	
15.	Other than the deviations listed in the deviation table, all other specifications mentioned in the tender are confirmed.	
16.	Delivery terms as mentioned in the specification, (Clause 15 of section-A of this document “Delivery schedule”).	
17.	All the supplied items shall be provided with warranty against any defects for a period of 3 years from the date of acceptance by SDSC SHAR.	
18.	Loading at factory, transportation to SLC site, Unloading at site, watch & ward at site, hiring of material handling equipments are in the scope of the vendor.	
Technical Terms		
1.	Quality assurance plan (QAP) for fabrication and testing w.r.t to all the items shall be submitted to SDSC SHAR for approval.	
2.	The vendor shall maintain Quality records, history docketts and all documentation related to fabrication, inspection, testing and erection during realization. The vendor shall	

SLC RANGE FACILITIES – MODULAR CONSOLES, INSTRUMENTATION RACKS and CHAIRS

	submit all such documents to SDSC SHAR after delivery.	
3.	Vendor shall indicate clearly list of works planned to offload to his sub-vendor. In such cases, details of works and sub-vendors shall be provided.	
4.	Vendor shall submit all technical documents, datasheets, 3D drawings, fabrication drawings, BOMs and material specifications, inspection reposts, test reports to SDSC SHAR in the following form. <ul style="list-style-type: none">- 2 complete sets of physical copies.- One set of soft copies.	

Signature of Authorised representative of the vendor

Vendor's Stamp

इसरो ISRO