

**NavIC SIGNAL IN SPACE ICD
FOR
STANDARD POSITIONING SERVICE
IN L1 FREQUENCY**

VERSION 1.0



OCTOBER 2022

SATELLITE NAVIGATION PROGRAMME

**U.R. RAO SATELLITE CENTRE
INDIAN SPACE RESEARCH ORGANIZATION
BANGALORE**

**NavIC SIGNAL IN SPACE ICD FOR
STANDARD POSITIONING SERVICE
IN L1 FREQUENCY**

VERSION 1.0

OCTOBER 2022

REVIEWED BY

APPROVED BY

**U.R. RAO SATELLITE CENTRE
INDIAN SPACE RESEARCH ORGANIZATION
BANGALORE**

Revision record		
Version No	Description	Document release date
1.0	First release	

DRAFT

Preface

This document provides the Signal and the Data Structure for Standard Positioning Service (SPS) of NavIC (Navigation with Indian Constellation) in L1 frequency band. The document addresses the signal modulations, the frequency bands, the received power levels, the data-structures and their interpretations, user algorithms, etc.

DRAFT

Terms of Use & Disclaimers

The NavIC Signal-in-Space ICD for SPS in L1 Frequency is released to the public to provide the essential information on the NavIC signal-in-space, to facilitate research & development and aid the commercial use of the NavIC signals for navigation-based applications, according to the terms and conditions specified hereafter:

- The publishing authority does not make any assurance on the fitness of the information furnished in the document for any specific purpose. The contents of the document are only for information and the publishing authority does not assume any legal liability for any product developed based on the information. No liability is hereby assumed for any consequences arising out of the usage of the information contained in the NavIC SIS ICD for SPS in L1 Frequency.
- The information furnished in the NavIC SIS ICD for SPS in L1 Frequency could be subject to modification and update. Although the publishing authority shall take its best efforts to notify the public about the updates in the SIS ICD, it does not assume any obligation to advise any person or organization on its future updates of SIS ICD.

Copyright

The NavIC SIS ICD for SPS in L1 Frequency is protected by copyright. Any alteration or translation in any language of the NavIC Signal-in-Space ICD for SPS as a whole or parts of it is prohibited unless the Publishing Authority provides a specific written prior permission. The NavIC Signal-in-Space ICD for SPS may only be partly or wholly reproduced and/or transmitted to a third party for non-profit purposes, in accordance with the herein described permitted use and under the following conditions:

- The present “Terms of Use and Disclaimers” are accepted, reproduced and transmitted entirely and unmodified together with the reproduced and/or transmitted information;
- The copyright notice “© Indian Space Research Organization” is not removed from any page.

Table of Contents

1. INTRODUCTION.....	1
1.1 SCOPE OF THE DOCUMENT.....	1
1.2 DOCUMENT OVERVIEW.....	1
2 NavIC SYSTEM OVERVIEW	2
2.1 NavIC ARCHITECTURE	2
2.2 NavIC SPACE SEGMENT.....	2
2.3 NavIC GROUND SEGMENT.....	3
2.4 USER SEGMENT	3
2.5 NavIC SERVICES	3
3 SIGNAL CHARACTERISITCS	4
3.1 NavIC FREQUENCY BANDS	4
3.2 NavIC CARRIER FREQUENCIES	4
3.3 MODULATION SCHEME	4
3.3.1 Standard Positioning Service.....	4
3.3.2 Modulation.....	4
3.4 TRANSMITTED SIGNAL PHASE NOISE	8
3.5 CORRELATION LOSS.....	8
3.6 TRANSMITTED SIGNALS CODE/DATA COHERENCY	8
3.7 SPURIOUS CHARACTERISTICS.....	8
3.8 RECIEVED POWER LEVELS ON GROUND	8
3.8.1 Minimum Levels.....	8
3.8.2 Maximum Levels.....	8
3.9 POLARIZATION CHARACTERISTICS.....	9
3.10 CHANNEL GROUP DELAY	9
4 L1 SPS PRN CODES	10
4.1 CODE GENERATOR ARCHITECTURE FOR PRIMARY L1 PILOT AND L1 DATA PRN CODES.....	11
4.1.1 The Binary Shift Register R0.....	12
4.1.2 Binary Shift Register R1	14
4.1.3 Initial conditions for Shift Registers R0, R1 and C	19
4.2 SECONDARY OVERLAY CODE GENERATOR ARCHITECTURE	24

5 L1 SPS DATA STRUCTURE.....	32
5.1 BIT AND BYTE ORDERING CRITERIA.....	32
5.2 BCH CODING.....	32
5.3 LOW DENSITY PARITY CHECK ENCODING	33
5.3.1 LDPC Submatrices.....	34
5.4 INTERLEAVING	35
5.5 CYCLIC REDUNDANCY CHECK (CRC).....	35
5.6 NavIC SYSTEM TIME	35
5.7 COORDINATE SYSTEM.....	36
5.8 FRAME STRUCTURE	36
5.8.1 Sub Frame Structure	36
5.9 NAVIGATION DATA	37
5.9.1 Primary Navigation Parameters	37
5.9.2 Secondary Navigation Parameters	37
5.9.3 Idle Pattern.....	37
6 SUBFRAME STRUCTURE	38
6.1 SUBFRAME DATA FORMAT	38
6.1.1 Subframe 1 Data Format.....	38
6.1.2 Subframe 2 Data Format.....	38
6.1.3 Subframe 3 Data Format.....	40
6.2 DATA CONTENTS.....	45
6.2.1 Subframe 1 & Subframe 2	45
6.2.2 Subframe 3.....	49
6.3 BROADCAST INTERVAL	56
Appendix A. Algorithm for Ephemeris Computation.....	59
Appendix B. User Algorithms for SV Clock Correction Data	61
Appendix C. Inter-signal Correction for Single and Dual frequency users.....	62
Appendix D. User Algorithm for Ionosphere Delay Corrections for Single Frequency User using Ionosphere Grid Corrections	65
Appendix E. User Algorithm for Satellite Position determination using Almanac ...	69

Appendix F.	User Algorithm for computation of NavIC time offset w.r.t UTC, UTC(NPLI) and other GNSS	71
Appendix G.	User Algorithm for application of Earth Orientation Parameters (EOP)	73
Appendix H.	User Algorithm For Ionosphere Delay computation using Klobuchar like ionosphere coefficients	74
Appendix I.	(Reserved for new NavIC Iono algorithm)	76
Appendix J.	LDPC Sub- Matrices.....	77

DRAFT

List of figures

Figure 1: NavIC Architecture	2
Figure 2: NavIC Space Segment Interface with User Segment	3
Figure 3 :Frequency bands of NavIC Signals	4
Figure 4: SBOC Signal Generation.....	7
Figure 5: Tiered code structure and timing relationship between primary and secondary codes	10
Figure 6: Functional Description of IZ4 Sequence generation using Binary shift registers....	13
Figure 7: Feedback logic used to generate the linear feedback to Register R0 for IZ4 codes. 14	
Figure 8: R1A and R1B computation for R1 feedback determination for primary IZ4 codes	16
Figure 9: σ_{2A} and σ_{2B} computation for R1A determination for primary IZ4 codes.....	17
Figure 10: σ_{2C} and σ_{2D} computation for R1A determination for primary IZ4 codes.....	18
Figure 11: R1 Feedback computation using R1 and R0 shift register taps for primary IZ4 codes	19
Figure 12: Block Diagram of overlay sequence generator	25
Figure 13: Feed Back Computation for R0 and R1A determination for overlay codes	29
Figure 14: σ_{2A} and σ_{2B} computation for overlay codes.....	30
Figure 15: R1 Register feedback computation for overlay codes.....	31
Figure 16 : NavIC L1 SPS Subframe Structure	32
Figure 17 : Diagram of the BCH Encoder Circuit	32
Figure 18: Parity-check matrix H and its sub-matrix size	33
Figure 19: Master Frame Structure	36
Figure 20: Sub-frame 1 Layout.....	36
Figure 21: Sub-frame 2 Layout.....	36
Figure 22: Sub-frame 3 Layout.....	37
Figure 23: Identified IGPs for Grid Based Corrections over Indian Region	50
Figure 24: Ionospheric Pierce Point Geometry.....	65
Figure 25: Example of 5x5o triangle	66
Figure 26: Four Point Interpolation Algorithm.....	66
Figure 27: Three Point Interpolation Algorithm.....	67

List of tables

Table 1: Carrier Frequencies and bandwidths	4
Table 2: Symbol Definitions	6
Table 3: SBOC coefficients	7
Table 4: Parameters for Composite Signal Generation.....	7
Table 5: Minimum received power of signals	8
Table 6: Characteristics of the L1 ranging codes.....	11
Table 7: L1 Band SPS IZ4 Data PRN codes for PRN IDs 1 to 64	19
Table 8:L1 Band SPS IZ4 Pilot PRN codes for PRN IDs 1 to 64	21
Table 9: Initial conditions of R0 and R1 shift registers, initial and last 24	26
Table 10: Generator polynomials of BCH encoders.....	33
Table 11: Interleaving parameters	35
Table 12: Sub frame 1 data format	38
Table 13: Sub frame2 data format	38
Table 14: NavIC SPS L1 Signal Message Types.....	40
Table 15: Message Type 5 format	41
Table 16: Message Type 6 format	42
Table 17: Message type 10 format.....	43
Table 18: Message Type 17 format	44
Table 19: IODEC Range.....	46
Table 20: Signal Health Flags.....	47
Table 21: URA Index to URA Mapping.....	47
Table 22: List of Ephemeris parameters	48
Table 23: Signal Delay Parameters.....	49
Table 24: Region Id and index for identified IGP locations	51
Table 25: Evaluation of GIVEI.....	53
Table 26: Almanac Parameters Definitions	53
Table 27: GNSS ID to GNSS Mapping	56
Table 28: Maximum Broadcast Interval	57
Table 29: LDPC Submatrix A for Subframe 2 * (sheet 1 of 9).....	77
Table 30: LDPC Submatrix B for Subframe 2 *	85
Table 31: LDPC Submatrix C for Subframe 2 *.....	86

Table 32: LDPC Submatrix D for Subframe 2 *	86
Table 33: LDPC Submatrix E for Subframe 2 *	87
Table 34: LDPC Submatrix T for Subframe 2 * (sheet 1 of 4)	88
Table 35: LDPC Submatrix A for Subframe 3 * (sheet 1 of 4)	92
Table 36: LDPC Submatrix B for Subframe 3 *	95
Table 37: LDPC Submatrix C for Subframe 3 *	96
Table 38: LDPC Submatrix D for Subframe 3 *	96
Table 39: LDPC Submatrix E for Subframe 3 *	96
Table 40: LDPC Submatrix T for Subframe 3 * (sheet 1 of 2)	97
Table 41: Number of 1's in LDPC Submatrix A for Subframe 2	98
Table 42: Number of 1's in LDPC Submatrix B for Subframe 2	98
Table 43: Number of 1's in LDPC Submatrix C for Subframe 2	99
Table 44: Number of 1's in LDPC Submatrix D for Subframe 2	99
Table 45: Number of 1's in LDPC Submatrix E for Subframe 2	99
Table 46: Number of 1's in LDPC Submatrix T for Subframe 2	99
Table 47: Number of 1's in LDPC Submatrix A for Subframe 3	99
Table 48: Number of 1's in LDPC Submatrix B for Subframe 3	100
Table 49: Number of 1's in LDPC Submatrix C for Subframe 3	100
Table 50: Number of 1's in LDPC Submatrix D for Subframe 3	100
Table 51: Number of 1's in LDPC Submatrix E for Subframe 3	100
Table 52: Number of 1's in LDPC Submatrix T for Subframe 3	100

1. INTRODUCTION

1.1 SCOPE OF THE DOCUMENT

The Signal-In-Space (SIS) Interface Control Document (ICD) for Standard Positioning Service in L1 Frequency band specifies the interface between the NavIC space segment and the NavIC user segment for SPS service in L1 frequency band.

1.2 DOCUMENT OVERVIEW

The document is organized as follows:

- Chapter 1 contains the scope of the document.
- Chapter 2 contains the NavIC system overview.
- Chapter 3 contains the signal characteristics such as frequency bands, modulation, PRN codes and frame structure.
- Chapter 4 provides the characteristics of the spreading codes.
- Chapter 5 provides the features of data structure for SPS in L1 frequency.
- Chapter 6 provides the formats and the contents of the sub-frames.

2 NavIC SYSTEM OVERVIEW

Navigation with Indian Constellation (NavIC) is an independent, indigenously developed satellite navigation system fully planned, established and controlled by the Indian Space Research Organization (ISRO). NavIC was earlier known as Indian Regional Navigation Satellite System (IRNSS).

2.1 NavIC ARCHITECTURE

The NavIC architecture mainly consists of:

- Space Segment
- Ground Segment
- User Segment

Figure 1 below depicts the NavIC architecture

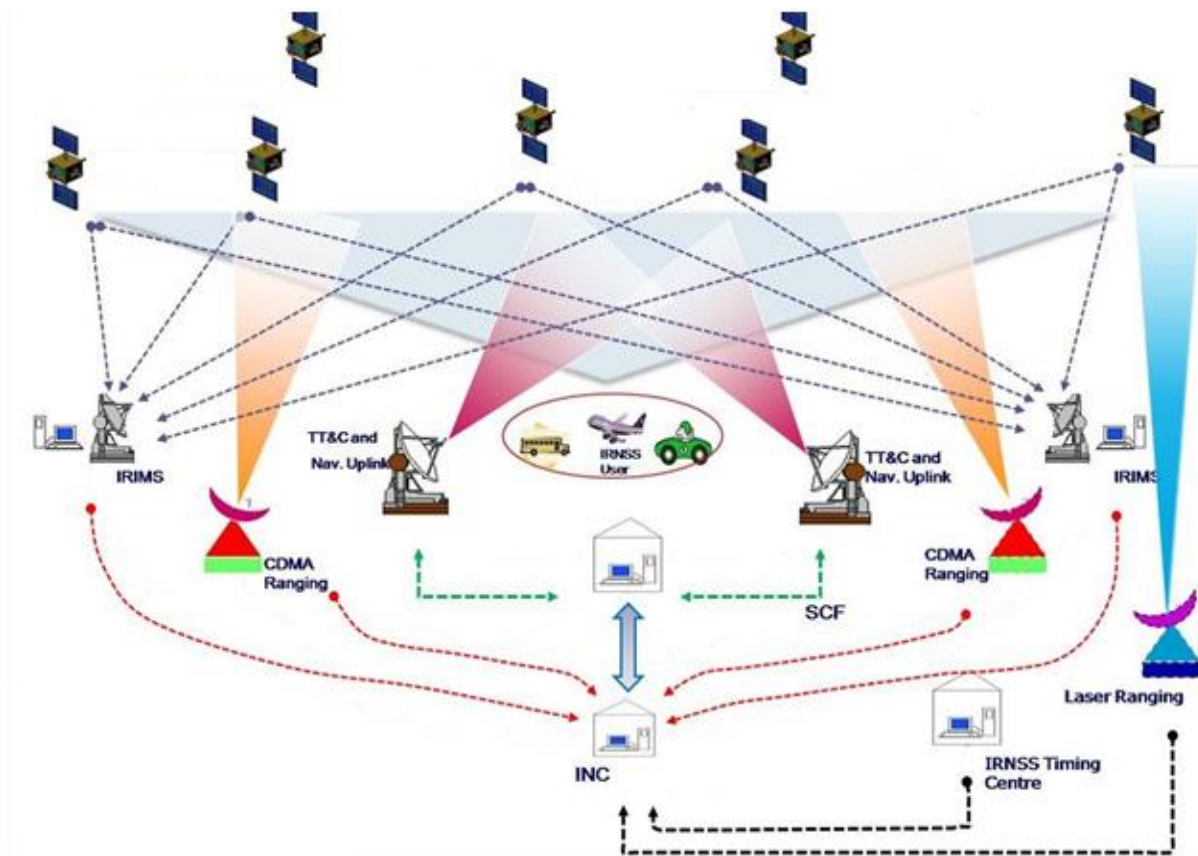

Figure 1: NavIC Architecture

2.2 NavIC SPACE SEGMENT

Based on various considerations the NavIC constellation is worked out to be a combination of GSO and IGSO satellites.

2.3 NavIC GROUND SEGMENT

Ground segment is responsible for the maintenance and operation of the NavIC constellation. The ground segment comprises of:

- ISRO Navigation Centre (INC)
- IRNSS Spacecraft Control Facility (IRSCF)
- IRNSS Range and Integrity Monitoring Stations (IRIMS)
- IRNSS Network Timing (IRNWT) Facility
- IRNSS CDMA Ranging Stations (IRCDR)
- Laser Ranging Stations
- Data Communication Network

2.4 USER SEGMENT

The User segment mainly consists of:

- Single frequency NavIC receiver capable of receiving signal in L1 / L5 / S band frequency.
- A multi-frequency NavIC receiver capable of receiving combinations of L1, L5 and S band signals.
- A multi-constellation receiver compatible with NavIC and other GNSS signals.

The Figure 2 below specifies the radio frequency interface between space and user segments. Each NavIC satellite provides SPS signals in L1, L5 and S bands.

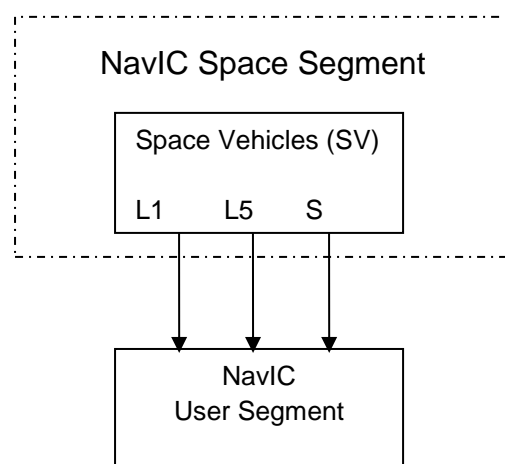

Figure 2: NavIC Space Segment Interface with User Segment

2.5 NavIC SERVICES

Standard Position Services (SPS), an open service without encryption and Restricted Service (RS), an authorized service with encryption are the navigation services offered by NavIC. NavIC also disseminates one-way broadcast messages to users in the Indian region.

3 SIGNAL CHARACTERISTICS

3.1 NavIC FREQUENCY BANDS

The NavIC SPS service is transmitted on L5 (1164.45 – 1188.45 MHz), L1 (1563.42 MHz – 1587.42 MHz) and S (2483.5 – 2500 MHz) bands. The frequencies in L5, L1 and S bands have been selected in the allocated spectrum of Radio Navigation Satellite Services as indicated in in Figure 3 below.

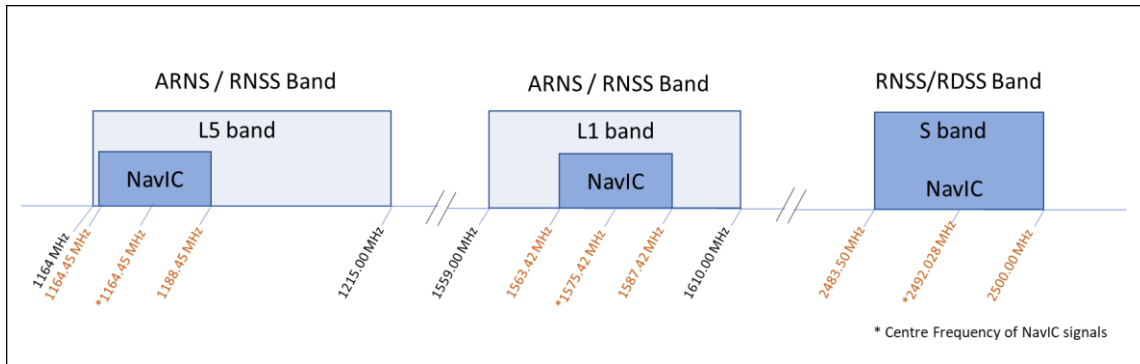

Figure 3 :Frequency bands of NavIC Signals

3.2 NavIC CARRIER FREQUENCIES

The NavIC carrier frequencies and the bandwidths of transmission for the SPS service is shown in Table 1 below.

Table 1: Carrier Frequencies and bandwidths

Signal	Carrier Frequency	Bandwidth
SPS – L1	1575.42 MHz	24 MHz (1563.42 - 1587.42 MHz)
SPS – L5	1176.45 MHz	24 MHz (1164.45 - 1188.45 MHz)
SPS – S	2492.028 MHz	16.5 MHz (2483.50 - 2500.00MHz)

3.3 MODULATION SCHEME

3.3.1 Standard Positioning Service

The SPS signal is modulated using Synthesized Binary Offset Carrier (SBOC) in L1 band and BPSK(1) in L5 & S bands.

3.3.2 Modulation

SBOC modulation contains the data signal and pilot signal. Both data and pilot signals contain the BOC(1,1) and BOC(6,1) components. In this modulation scheme, data channel BOC(1,1), pilot channel BOC(1,1) and pilot channel BOC(6,1) components are interplexed to generate data channel BOC(6,1) component. Further, the data and the pilot signals are quadrature multiplexed with each other with power sharing of former and latter being 41.82% and 58.18%, respectively to generate the constant envelope modulation and meet the power spectral density of multiplexed binary offset carrier (MBOC) modulation scheme.

3.3.2.1 Mathematical Description

The mathematical description for baseband navigation signals is as follows:

Pilot Signal

$$S_{p,a}(t) = \sum_{i=-\infty}^{\infty} C_p(|i|_{L_p}). \text{rect}_{T_{c,p}}(t - iT_{c,p}). sc_{p,a}(t, 0) \dots \dots \dots (1)$$

$$S_{p,b}(t) = \sum_{i=-\infty}^{\infty} C_p(|i|_{L_p}). \text{rect}_{T_{c,p}}(t - iT_{c,p}). sc_{p,b}(t, 0) \dots \dots \dots (2)$$

The sub-carrier is defined as:

$$sc_{p,x}(t, \varphi) = \text{sgn}[\sin(2\pi f_{sc,x}t + \varphi)] \dots \dots \dots (3)$$

The subcarrier signals are sinBOC. Hence, the subcarrier phase $\varphi=0$.

Ranging code C_p , defined in equations (1) & (2), includes primary code and secondary overlay code as defined in section-4.

Data Signal

$$S_{d,a}(t) = \sum_{i=-\infty}^{\infty} C_d(|i|_{L_d}). d_d([i]_{CD_d}). \text{rect}_{T_{c,d}}(t - iT_{c,d}). sc_{d,a}(t, 0) \dots \dots \dots (4)$$

The sub-carrier is defined as:

$$sc_{d,x}(t, \varphi) = \text{sgn}[\sin(2\pi f_{sc,x}t + \varphi)] \dots \dots \dots (5)$$

The subcarrier signals are sinBOC. Hence, the subcarrier phase $\varphi=0$.

Ranging code C_d , defined in equation (4), includes primary code only as defined in section-4.

In this scheme, sinBOC(6,1) component of the data signal, i.e., $S_{d,b}(t)$ is generated by interplexing of the sinBOC(1,1) component of data signal ($S_{d,a}(t)$), sinBOC(1,1) component of pilot signal ($S_{p,a}(t)$) and sinBOC(6,1) component of pilot signal ($S_{p,b}(t)$) which is given as follows:

$$S_{d,b}(t) = S_{d,a}(t). S_{p,a}(t). S_{p,b}(t) \dots \dots \dots (6)$$

Equation (6) is rearranged to represent the interplexed component $S_{d,b}(t)$ which is given below,

$$S_{d,b}(t) = \sum_{i=-\infty}^{\infty} C_d(|i|_{L_d}). d_d([i]_{CD_d}). \text{rect}_{T_{c,d}}(t - iT_{c,d}). sc_{d,b}(t, 0) \dots \dots \dots (7)$$

The sub-carrier is defined as:

$$sc_{d,x}(t, \varphi) = \text{sgn}[\sin(2\pi f_{sc,x}t + \varphi)] \dots \dots \dots (8)$$

The subcarrier signals are sinBOC. Hence, the subcarrier phase $\varphi=0$.

Ranging code C_d , defined in equation (7), includes primary code only as defined in section-4.

The composite SBOC modulated signal ($S(t)$) is generated by quadrature multiplexing of data and pilot signals which is given below:

$$S(t) = [\alpha S_{p,a}(t) - \beta S_{p,b}(t)] + j[\gamma S_{d,a}(t) + \eta S_{d,b}(t)] \dots \dots \dots (9)$$

Baseband composite SBOC modulated signal ($S(t)$) is also represented as,

$$S(t) = S_I(t) + jS_Q(t) \dots \dots \dots (10)$$

Hence based on equation (10), band-pass representation of SBOC modulated navigation signal ($S_{RF}(t)$) at L1 band is defined as follows,

$$S_{RF}(t) = S_I(t) \cdot \cos(2\pi f_{L1}t) - S_Q(t) \cdot \sin(2\pi f_{L1}t) \dots \dots \dots (11)$$

where, f_{L1} is 1575.42 MHz frequency.

Symbol definitions are given in the Table 2 below

Table 2: Symbol Definitions

Symbol	Description
$C_d(i)$	'i'th chip of spreading code of data channel
$C_p(i)$	'i'th chip of spreading code of pilot channel
$d_d(i)$	'i'th bit of navigation message of data channel
$sc_{p,x}(t)$	Binary NRZ subcarrier
$sc_{d,x}(t)$	Binary NRZ subcarrier
$ i _X$	'i' modulo 'X'
$[i]_X$	Integer part of (i/X)
CD_x	No. of chips per navigation data bit
L_x	Length of spreading code in chips
$rect_x(t)$	Rectangle pulse function with duration 'x'
$T_{c,x}$	Spreading code chip duration
$f_{sc,x}$	Subcarrier frequency
φ	Subcarrier phase

The operation $|i|_X$ gives the code chip index for any signal. Similarly $[i]_X$ gives data bit index for any signal.

The coefficients for SBOC generation are given in the Table 3 below.

Table 3: SBOC coefficients

Coefficient	Value
α	$\sqrt{6/11}$
β	$\sqrt{4/110}$
γ	$\sqrt{4/11}$
η	$\sqrt{6/110}$

The Figure 4 below depicts the block diagram of the modulation scheme.

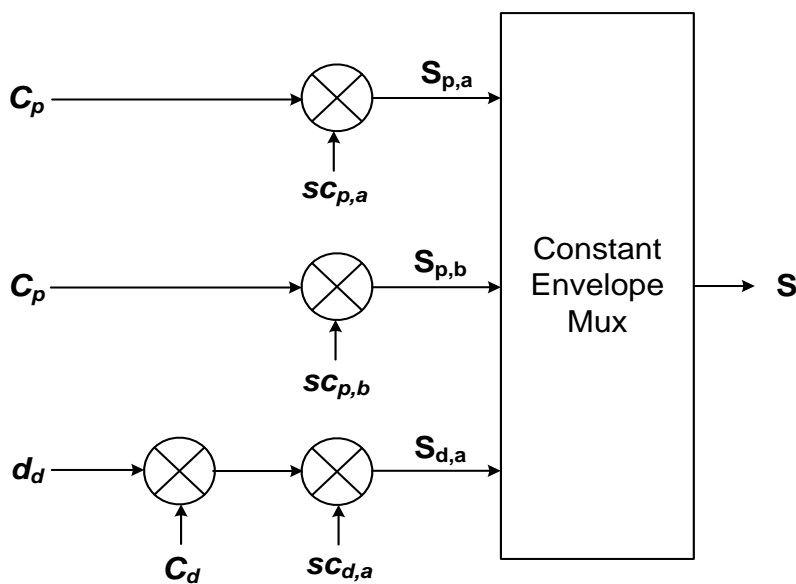
Figure 4: SBOC Signal Generation

The Table 4 below shows parameter description for composite signal generation.

Table 4: Parameters for Composite Signal Generation

Symbol	Description	Value
R_d	Symbol rate of navigation message in data channel (d_d)	100 symbols/sec
R_c	Code chip rate of pilot signal code (C_p) and data signal code (C_d)	1.023 Mcps
$f_{sc,a}$	Sub-carrier frequency of $sc_{p,a}(t)$ and $sc_{d,a}(t)$ sub-carriers	1.023 MHz
$f_{sc,b}$	Sub-carrier frequency of $sc_{p,b}(t)$ and $sc_{d,b}(t)$ sub-carriers	6.138 MHz

3.4 TRANSMITTED SIGNAL PHASE NOISE

The Phase Noise spectral density of the un-modulated carrier will allow a second order phase locked loop with 10 Hz one sided noise bandwidth to track the carrier to an accuracy of 0.035 radians RMS.

3.5 CORRELATION LOSS

Correlation loss is defined as the difference between the transmitted power received in the specified signal bandwidth and the signal power recovered in the ideal receiver of the same bandwidth, which perfectly correlates using an exact replica of the waveform within an ideal band-pass filter with linear phase. For NavIC L1 band signals, the correlation loss that occurs in the navigation payload shall not exceed 0.3 dB.

3.6 TRANSMITTED SIGNALS CODE/DATA COHERENCY

The raising/ leading edge of each data symbol coincides with the starting edge of the PRN code chip. The starting edge of each overlay code chip coincides with the starting edge of primary code chip.

3.7 SPURIOUS CHARACTERISTICS

For all NavIC signals, in-band spurious transmission shall be -50 dB or below with respect to power level of un-modulated carrier wave.

3.8 RECIEVED POWER LEVELS ON GROUND

3.8.1 Minimum Levels

The Table 5 below indicates the assured minimum power levels of the NavIC signals received by a user receiver on ground. The minimum received power on ground is measured at the output of an ideally matched RHCP 0 dBi user receiving antenna when the spacecraft elevation angle is higher than 5°.

Table 5: Minimum received power of signals

Signal	Signal Component	Minimum Received Power (dBW)	Total Minimum Received Power (dBW)
L1	SPS Data	(-159.6)	-155.8
	SPS Pilot	(-158.2)	

3.8.2 Maximum Levels

The maximum power level of the NavIC composite L1 SPS signal received by a user receiver on ground is not expected to exceed -152 dBW. The maximum received power on ground is measured at the output of an ideally matched RHCP 0 dBi user receiving antenna when the spacecraft elevation angle is higher than 5°.

3.9 POLARIZATION CHARACTERISTICS

All the NavIC signals are Right Hand Circularly Polarized. The antenna axial ratio does not exceed 2.0 dB.

3.10 CHANNEL GROUP DELAY

Channel group delay is defined as a time difference between transmitted RF signal (measured at phase center of transmitting antenna) and signal at the output of the onboard frequency source.

There are three different delay parameters: Fixed/Bias group delay, Differential group delay and Group delay uncertainty in bias and differential value.

The fixed delay or Hardware group delay is a bias term. It is included in the clock correction parameters transmitted in the navigation data, and is therefore accounted for by the user computations of system time.

The group delay uncertainty shows the variability in the path delay due to operational environment uncertainty and other factors. The effective uncertainty of the group delay shall not exceed 3ns (2σ).

Differential Group Delay is the delay difference between two navigation signals. It consists of random plus bias components. The mean differential is defined as the bias component and will be either positive or negative. The random variations about the mean shall not exceed 3ns (2σ). To correct the bias component of the group delay, TGD parameter is provided to the user in the navigation message.

4 L1 SPS PRN CODES

NavIC employs Pseudo-Random Noise (PRN) ranging codes drawn from the Interleaved Z4-linear (IZ4) ranging code family as primary codes for SPS signal in the L1 frequency band. Codes in the IZ4 family are generated using a pair of coupled binary, non-linear, feedback shift registers. Each GSO/IGSO satellite, is assigned a unique PRN ranging code number, termed as PRN ID, that applies to all operational signals of that satellite. PRN ranging codes, both primary and overlay, associated to the particular satellite are assigned to the given PRN ID. A unique and carefully optimized pair of IZ4 ranging codes that serve as the primary data -pilot code pair is assigned to PRN ID for associated each satellite. Each primary pilot code associated to each satellite is also modulated with an overlay code that is unique to the particular satellite. Overlay code are also termed as secondary codes in the document.

Thus, the L1 SPS PRN ranging codes for pilot component $L1P_i(t)$ and data component $L1D_i(t)$ associated to signal PRN ID “i” are all distinct, independent and are time-synchronized IZ4 PRN codes. Both $L1P_i(t)$ and $L1D_i(t)$ codes have a period of 10230 chips which translates to 10 milliseconds in length when operating at a chipping rate of 1.023 Mcps.

The PRN code for the i^{th} pilot $L1P_i(t)$, is additionally, modulated with an overlay code $L1O_i(t)$ both associated to the same PRN ID “i”. The overlay codes $L1O_i(t)$ for different indices “i” are distinct, independent, time synchronized, and 18 seconds in length at a rate of 100 chips per second, for a total length of 1800 bits. Thus, the PRN code structure for the L1 pilot component is that of a tiered code, that is generated by XOR-ing the primary pilot code $L1P_i(t)$ with the secondary or overlay code $L1O_i(t)$. A tiered code structure is one, where the logic levels of a long high-frequency primary code, and a short low-frequency secondary code, are added together using XOR-operations. The chip duration of the secondary code coincides with the time duration of one entire period of the primary pilot code as explained in Figure 5. Therefore, the code length N_T of the tiered code is the product of the code length of the primary code, N_p , and the code length of the secondary code, N_s , yielding

$$N_T = N_p N_s.$$

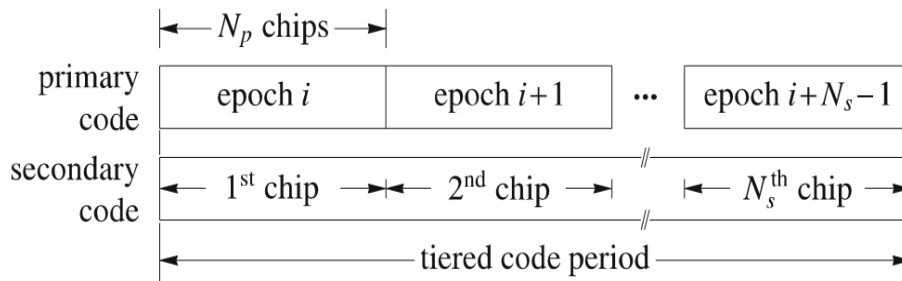

Figure 5: Tiered code structure and timing relationship between primary and secondary codes

The start of a secondary or overlay code chip is aligned with the start of the first chip of a primary pilot code. Primary pilot codes are IZ4 codes of length 10230 and secondary pilot codes are truncated Z4-linear codes of length 1800. The length of secondary codes is chosen

depending on the navigation data frame length needed to establish proper timing. The Table 6 below summarizes characteristics of the L1 SPS PRN ranging codes employed.

Table 6: Characteristics of the L1 ranging codes

Signal component	Primary code type	Primary code length	Primary code period (msec)	Secondary or overlay code type	Secondary or overlay code length	Secondary or overlay code period (msec)
L1 Data * (L1D _i (t))	Interleaved Z4-linear (IZ4) sequences	10230	10	-	-	-
L1 Pilot (L1P _i (t))	Interleaved Z4-linear (IZ4) sequences	10230	10	Truncated Z4-linear sequences	1800	18000
*The L1 primary data code is not modulated by a secondary or overlay code.						

4.1 CODE GENERATOR ARCHITECTURE FOR PRIMARY L1 PILOT AND L1 DATA PRN CODES

Both L1P_i(t) and L1D_i(t) are binary IZ4 codes and are constructed using the same method. The PRN code generator for L1P_i(t) and L1D_i(t) is realized using three simple binary shift registers. The IZ4 ranging code generator has the following principal components:

1. Two fifty-five tap binary shift registers, labelled respectively as R0 and R1,
2. A single, five-tap, binary, pure-cycling shift register labeled as C.

An IZ4 code is generated as the chip-by-chip modulo-2 sum of the synchronized output of Shift Register C, taken from its first tap C(0) and R1(0), taken from the first tap of register R1 as given in the equation below.

$$IZ4(t) = C(t,0) \oplus R1(t, 0). \dots\dots\dots(12)$$

In the equation above, by C(t,0) is meant the first tap of Register C at time t, and by R1(t,0) is meant, the contents of the first tap of register R1 at time t. Where the meaning is clear from the context, C(t,0) and R1(t,0) will be abbreviated and written as C(0) and R1(0) respectively. The symbol \oplus represents the logical XOR operation that computes the modulo-2 sum of two binary bits. All three registers are synchronized with respect to each other. Figure 6 describes IZ4 code generation using binary shift registers. The functional description of each register is given below.

4.1.1 The Binary Shift Register R0

A fifty-five tap long R0 shift register is the first component. This shift register is used to generate component binary codes of period 10230. The shift register shifts its contents at each clock instant. The initial contents of the register are determined by initial condition values stored in memory. The output of the shift register is a binary code sequence, having a period of 10230 chips. The register is reset to its initial value after 10230 clock cycles. At each clock instant, the shift register's contents go through a set of modulo-2 addition operations to generate feedback and the output of the feedback is fed back to the last, i.e., the 55th tap of the shift register. The output of the component code is drawn from the first tap R0(0) of the shift register. Feedback operation is governed by a feedback polynomial. The same feedback polynomial is used to generate all IZ4 ranging codes using different initial conditions. Out of a total of 55 taps, the following seven taps are utilized to generate the feedback for Register R0 as per recursion below:

$$\mathbf{R0(54) = R0(50) \oplus R0(45) \oplus R0(40) \oplus R0(20) \oplus R0(10) \oplus R0(5) \oplus R0(0). \dots(13)}$$

In the equation above, the quantities on the right are contents of the various taps of Register R0 at time t while on the left, contents at time (t+1). Thus, on the left by R0(54) is meant R0(t+1,54), whereas on the right, by R0(20) for example, is meant R0(t,20). At time t=0, all register taps are initialized with the initial conditions stored in memory. The feedback logic that is used to generate the linear feedback to Register R0 is shown in Figure 7. In the figure, the inputs to the logic circuit on the left, represent contents of the different taps of Register R0 at time t. The output in Figure 7 on the right, however, represents the content R0(t+1,54) of the 55th tap of the Register R0 at time (t+1).

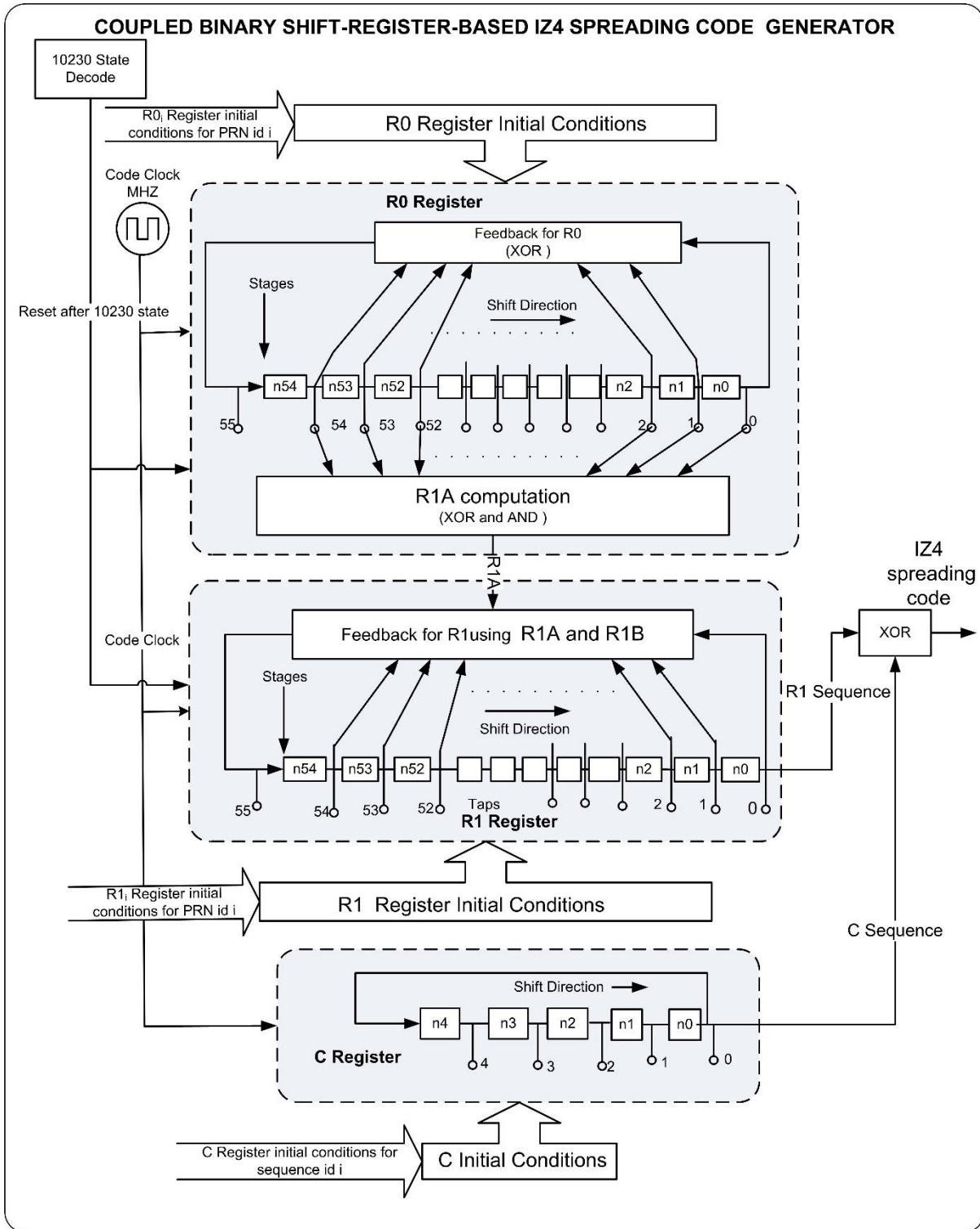

Figure 6: Functional Description of IZ4 Sequence generation using Binary shift registers.

The method of generation of the feedback for Register R0 is explained in Figure 7.

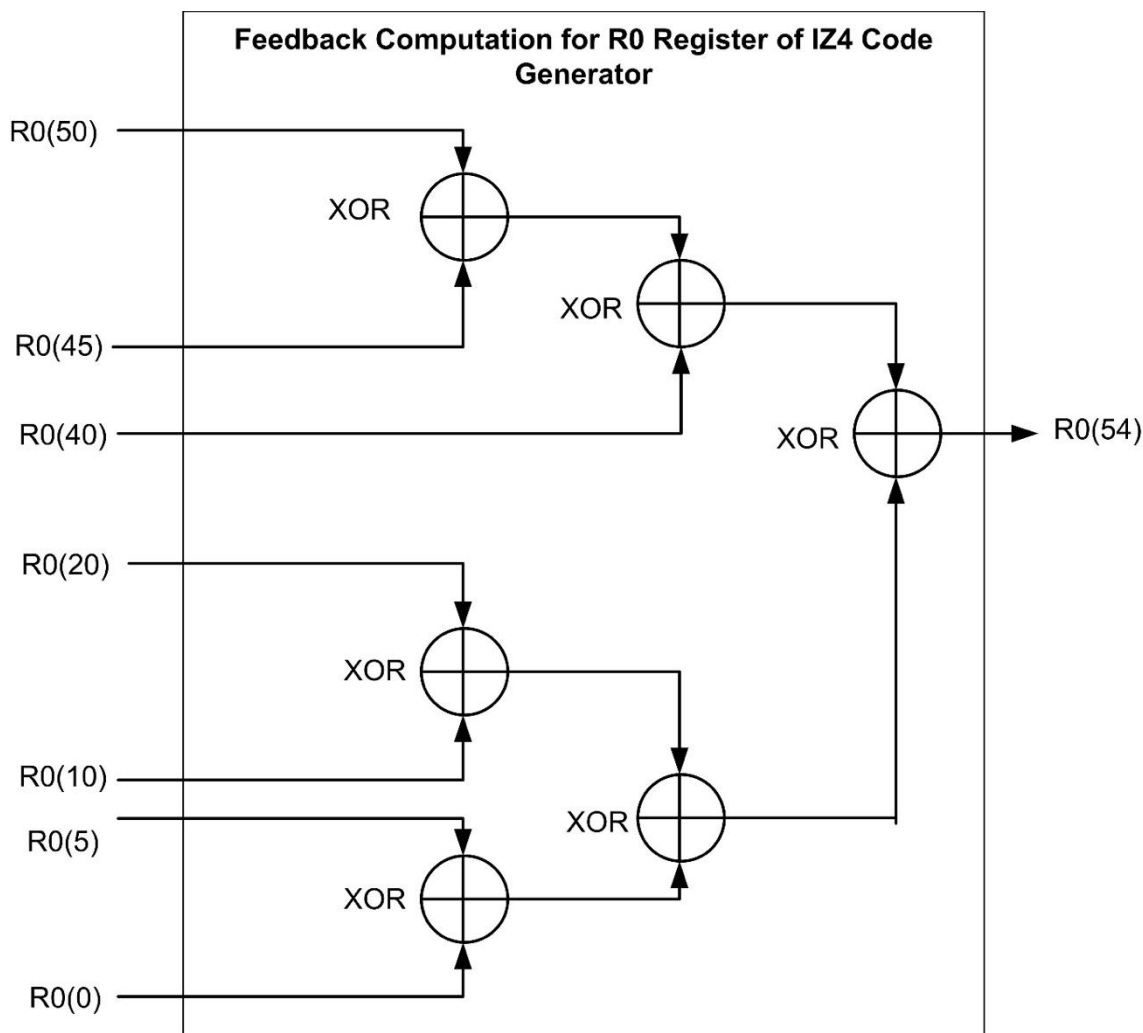

Figure 7: Feedback logic used to generate the linear feedback to Register R0 for IZ4 codes.

4.1.2 Binary Shift Register R1

The fifty-five-tap long R1 shift register generates the second component of the IZ4 ranging code. This shift register also generates a component binary code of period 10230. The shift register shifts its contents at each clock instant. The initial contents of shift register R1 are determined by initial condition values stored in memory. The output binary code has a period of 10230 chips. Register R1 is reset to its initial value after 10230 clock cycles. The component code's output is drawn from the contents of the first tap of the shift register. The feedback for register R1 is a non-linear function of the contents of the taps of both registers R1 and R0. The component of the feedback to register R1 that is a function of the contents of shift Register R0 is denoted by R1A.

The R1B component contains the contribution by the taps of register R1 to the feedback for Register R1. The feedback to register R1 is then the modulo-2 sum of feedback components

R1A and R1B. Three sub-components σ_{2A} , σ_{2B} and σ_{2C} , that are a function of the contents of the taps of Register R0, are computed as part of the computation involved in computing the R1A component of feedback. The modulo-2 sum of components R1A and R1B is fed back to the last, i.e., 55th tap of register R1. Identical feedback taps and logic are employed to generate all IZ4 sequences, using different initial conditions. The equations below specify the computations involved in generating the feedback for Register R1:

$$\sigma_{2A} = [\mathbf{R0(50)} \oplus \mathbf{R0(45)} \oplus \mathbf{R0(40)}] \text{ AND } [\mathbf{R0(20)} \oplus \mathbf{R0(10)} \oplus \mathbf{R0(5)} \oplus \mathbf{R0(0)}]. \quad \dots\dots(14)$$

$$\sigma_{2B} = ([\mathbf{R0(50)} \oplus \mathbf{R0(45)}] \text{ AND } \mathbf{R0(40)}) \oplus ([\mathbf{R0(20)} \oplus \mathbf{R0(10)}] \text{ AND } [\mathbf{R0(5)} \oplus \mathbf{R0(0)}]). \quad \dots\dots(15)$$

$$\sigma_{2C} = [\mathbf{R0(50)} \text{ AND } \mathbf{R0(45)}] \oplus [\mathbf{R0(20)} \text{ AND } \mathbf{R0(10)}] \oplus [\mathbf{R0(5)} \text{ AND } \mathbf{R0(0)}] \quad \dots\dots(16)$$

$$\sigma_2 = \sigma_{2A} \oplus \sigma_{2B} \oplus \sigma_{2C} \quad \dots\dots(17)$$

$$\mathbf{R1A} = \sigma_2 \oplus [\mathbf{R0(40)} \oplus \mathbf{R0(35)} \oplus \mathbf{R0(30)} \oplus \mathbf{R0(25)} \oplus \mathbf{R0(15)} \oplus \mathbf{R0(0)}]. \quad \dots\dots (18)$$

$$\mathbf{R1B} = \mathbf{R1(50)} \oplus \mathbf{R1(45)} \oplus \mathbf{R1(40)} \oplus \mathbf{R1(20)} \oplus \mathbf{R1(10)} \oplus \mathbf{R1(5)} \oplus \mathbf{R1(0)} \quad \dots\dots(19)$$

$$\mathbf{R1(54)} = \mathbf{R1A} \oplus \mathbf{R1B}. \quad \dots\dots(20)$$

In equations (14) through (19), all quantities shown correspond to contents of registers or functions of their contents at time t. With respect to equation (20), the quantity on the left represents the contents R1(t+1,54) of the 55th tap R1(54) of Register R1 at time (t+1) computed as a function of quantities computed on the right, at time t. At time t=0, all registers are initialized with the initial conditions stored in memory.

The figures below from Figure 8 to Figure 11 illustrate how the feedback computation for Shift Register R1 can be implemented. The quantities R1A and R1B appearing in Figure 11 on the left are the result of computations taking place at time t. On the right, in Figure 11, by R1(54), is meant the contents R1(t+1,54) at time (t+1), of the 55th tap of Register R1.

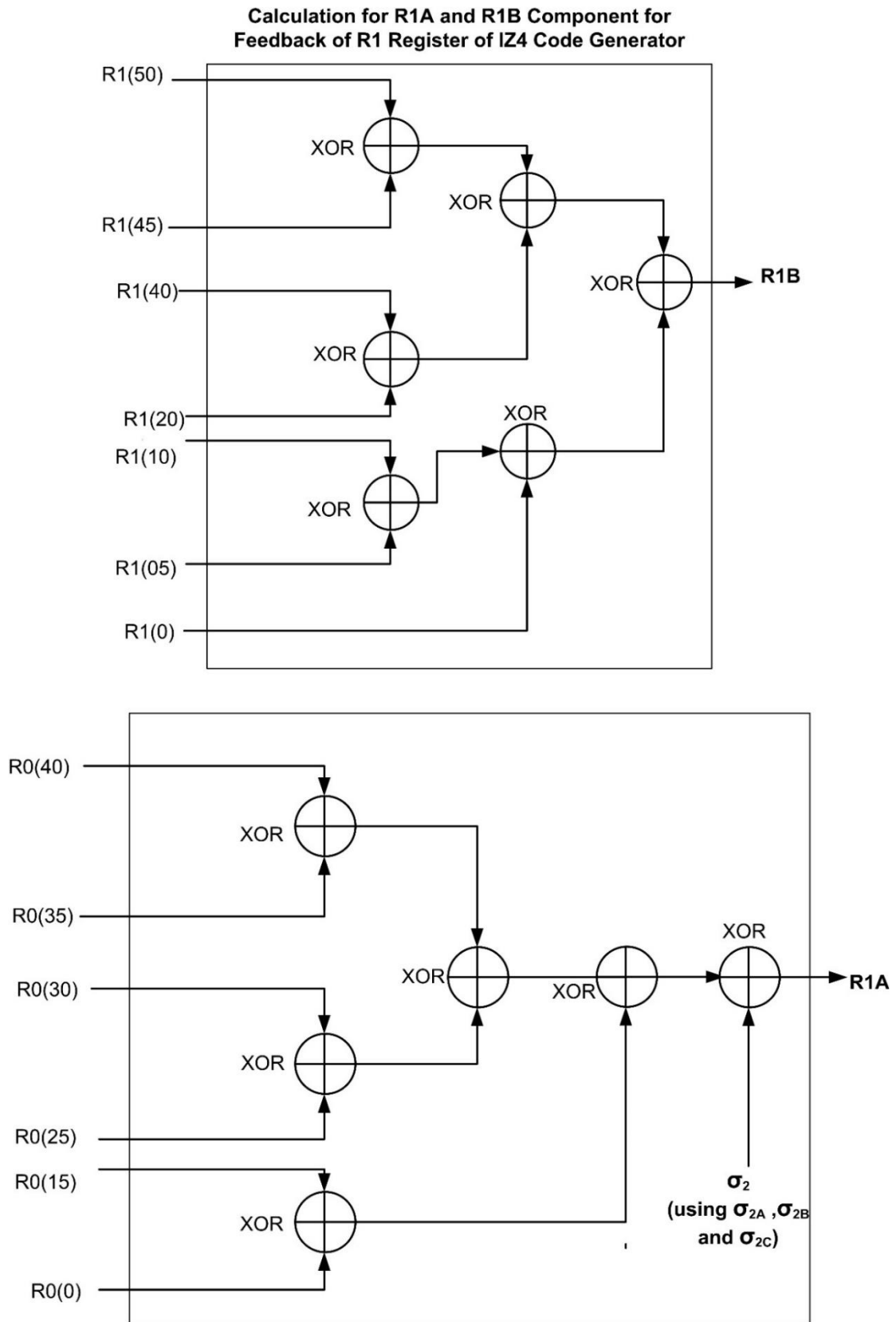

Figure 8: R1A and R1B computation for R1 feedback determination for primary IZ4 codes

σ_{2A} , σ_{2B} computation for feedback of R1 register of IZ4 Code Generator

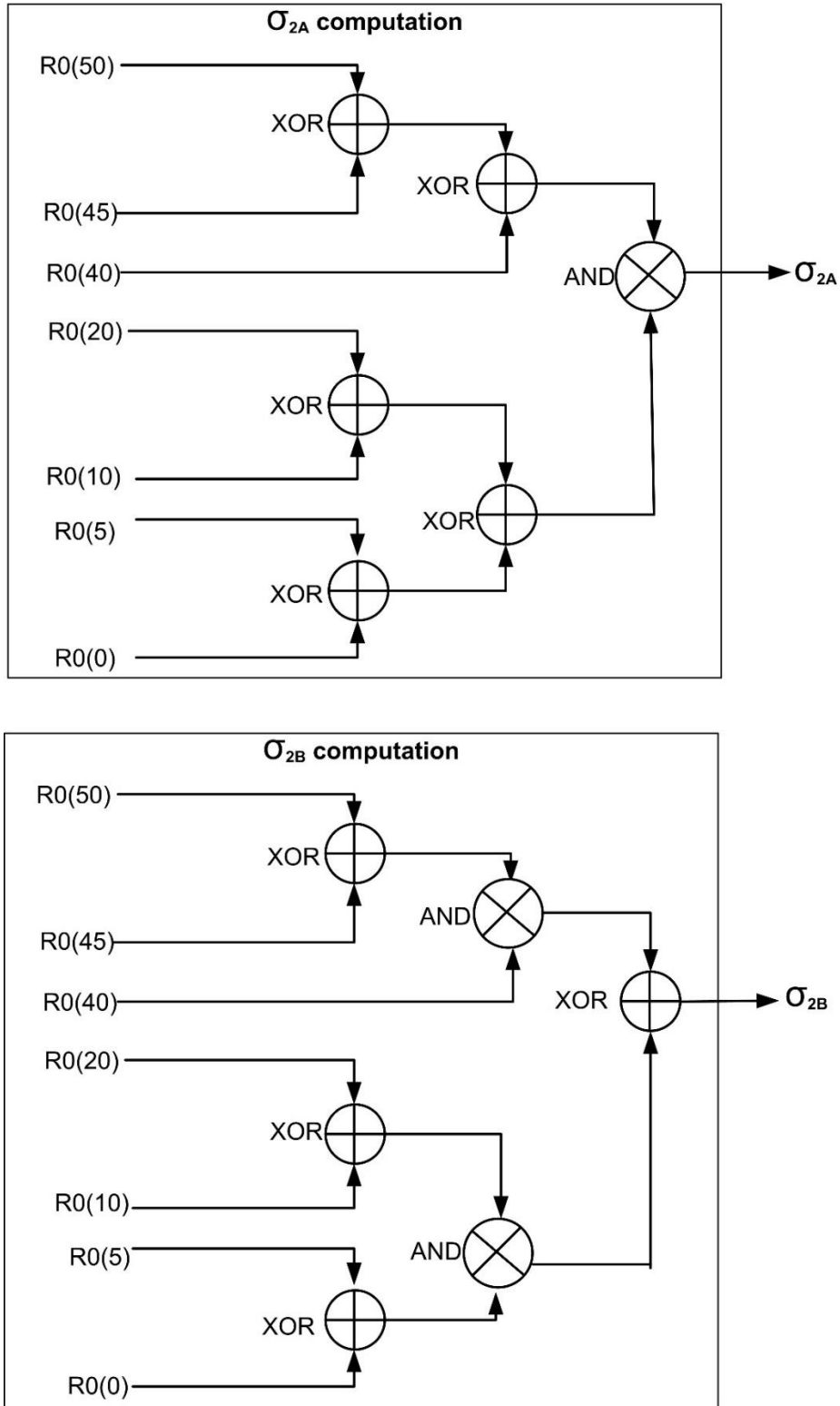

Figure 9: σ_{2A} and σ_{2B} computation for R1A determination for primary IZ4 codes

σ_{2c} and σ_2 Computation for Feedback of R1 Register of IZ4 Code Generator

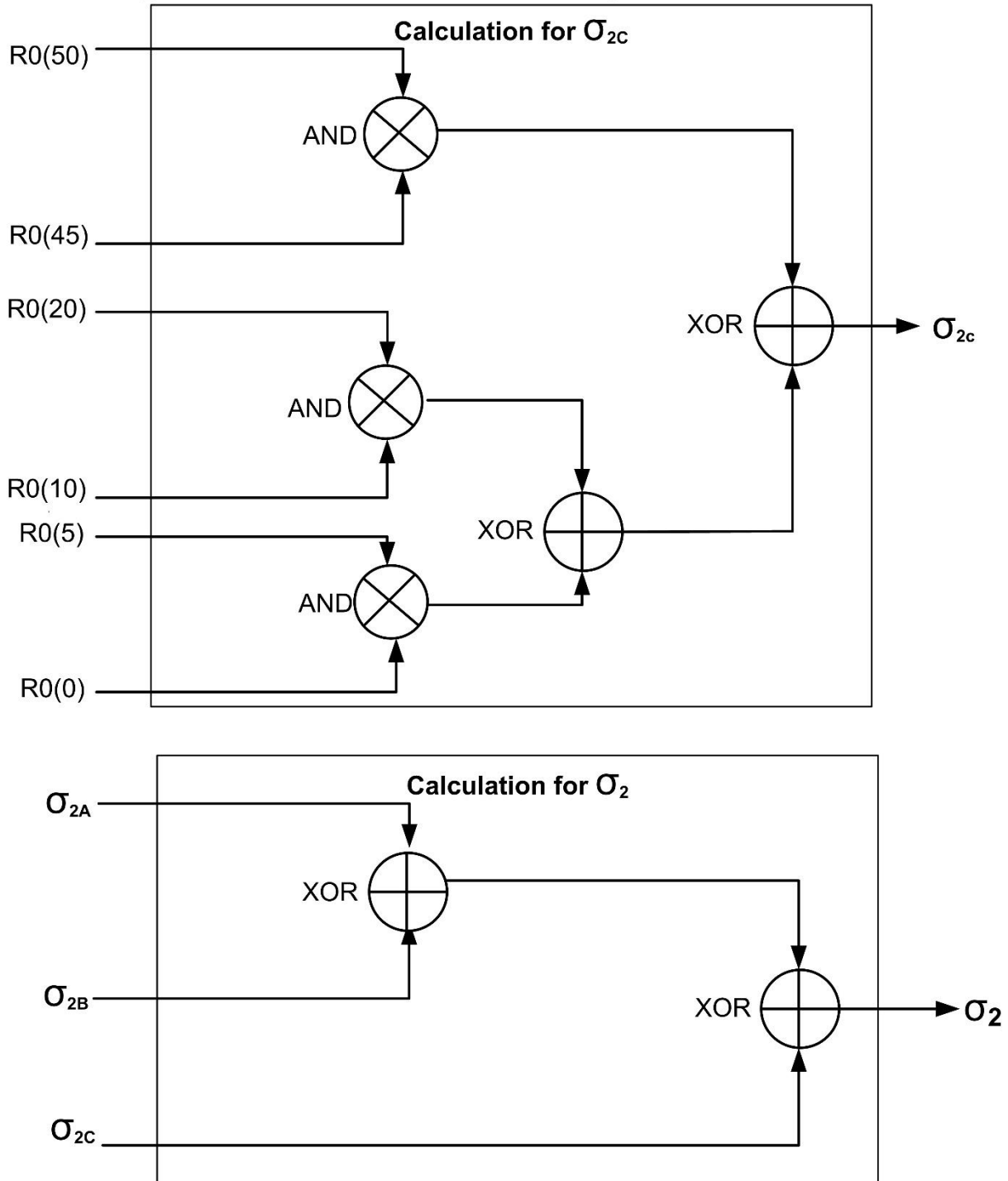

Figure 10: σ_{2c} and σ_2 computation for R1A determination for primary IZ4 codes

Calculation for R1 Register Feedback using R1A and R2B Components

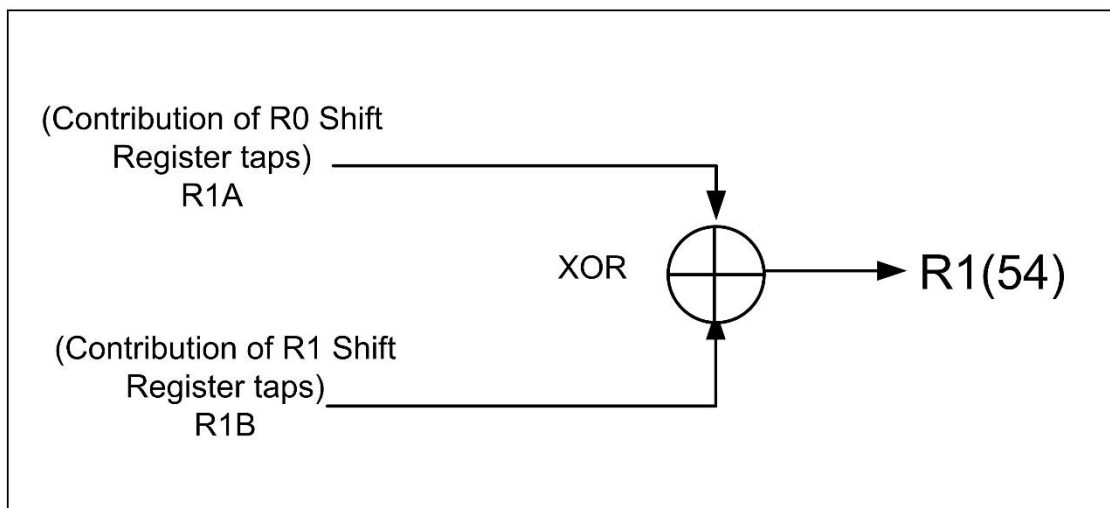

Figure 11: R1 Feedback computation using R1 and R0 shift register taps for primary IZ4 codes

4.1.3 Initial conditions for Shift Registers R0, R1 and C

Each R0 and R1 component code generator requires 55 bits of initial conditions. These initial conditions are unique to each IZ4 sequence and can be stored in memory. The initial conditions for shift registers R0 and R1 as well as the first and last bit patterns of the output IZ4 code (in octal format) are listed in Table 7 and Table 8 for both primary data and primary pilot codes.

Shift Register C is a 5-tap, pure-cycling shift register. The output of the first tap of register C is fed back as input to the fifth tap. The output of first tap C(0) is chip-by-chip XORed with the output of the R1 shift register to generate the IZ4 code. The corresponding five-bit initial conditions of register C associated to each PRN code are also given in the Table 7 and Table 8 below.

Table 7: L1 Band SPS IZ4 Data PRN codes for PRN IDs 1 to 64

*Initial Conditions for R0, R1 and C Shift Registers for Primary Data IZ4 codes				**First and Last 24 chip pattern for Primary Data IZ4 codes	
PRN ID	Initial Condition for R0 Shift Register in Octal (R0(0) to R0(54))	Initial Condition for R1 Shift Register in Octal (R1(0) to R1(54))	Initial Condition for C Register (Binary) for Data Codes C(0) to C(4)	First 24 bits (Octal)	Last 24 bits (Octal)
1.	0061727026503255544	0377627103341647600	10100	46555656	37436405
2.	1660130752435362260	0047555332635133703	10100	53142347	13443723
3.	0676457016477551225	0570574070736102152	00110	33721740	54403555
4.	1763467705267605701	0511013576745450615	10100	75664075	76447167
5.	1614265052776007236	1216243446624447775	10100	01536470	65327312
6.	1446113457553463523	0176452272675511054	00110	13424450	12250705
7.	1467417471470124574	0151055342317137706	10100	57666344	40632614

8.	0022513456555401603	1127720116046071664	00110	51073147	12652306
9.	0004420115402210365	0514407436155575524	00110	30526222	66712550
10.	0072276243316574510	0253070462740453542	00110	06645560	64762612
11.	1632356715721616750	0573371306324706336	10100	76773146	12063241
12.	1670164755420300763	1315135317732077306	00110	40543717	22556166
13.	1752127524253360255	1170303027726635012	10100	16630453	44473201
14.	0262220014044243135	1637171270537414673	00110	65441510	67166562
15.	1476157654546440020	0342370520251732111	00110	02211566	13320430
16.	1567545246612304745	0142423551056551362	10100	57305474	01701545
17.	0341667641424721673	0641261355426453710	00110	26355115	43741636
18.	0627234635353763045	0237176034757345266	00110	05441642	46230307
19.	0422600144741165152	1205663360515365064	00110	44175014	32771050
20.	1661124176724621030	0725000004121104102	00110	21146143	75574451
21.	1225124173720602330	0337367500320303262	10100	44573676	40642263
22.	1271773065617322065	1303374445022536530	10100	05373330	24326534
23.	0611751161355750124	1033071464007363115	10100	10767171	40773277
24.	0121046615341766266	0753124124237073577	00110	22643346	22461324
25.	0337423707274604122	0133522075443754772	10100	54741411	76760751
26.	0246610305446052270	1244212514312345145	00110	46116467	03527303
27.	0427326063324033344	1066056211234322164	00110	57004653	66557154
28.	1127467544162733403	0073115240113351010	00110	17642711	16063136
29.	0772425336125565156	1102260031574577224	00110	50215142	51326067
30.	1652465113031101044	1166703527236520553	10100	16110477	71663141
31.	1737622607214524550	0056062273631723177	10100	53527401	06070277
32.	1621315362240732407	0141517013160576212	00110	12362603	11643257
33.	0171733204500613155	1644007677312431616	10100	23024661	56713364
34.	1462031354327077565	0201757033615262622	00110	04370602	62132161
35.	1141265411761074755	0357610362675720200	00110	02476554	06014475
36.	0665106277260231251	1637504174727237065	00110	65462344	13315445
37.	0573123144343776027	1510345507743707753	10100	35632776	00162717
38.	0222101406610314705	0540160763721100120	10100	77223525	40736177
39.	0140673225434336401	0406415410457500342	01100	10534566	03337767
40.	0624233245727625631	0707515543554212732	00110	20062725	23035335
41.	0224022145647544263	0140216674314371011	00011	00153752	23070645
42.	0222501602610354705	0445414471314273300	01100	12474525	04163312
43.	1370337660412244327	0120121661750263177	10100	54221561	15476027
44.	0563567347256715524	0477301251340044262	00110	37452111	34567142
45.	1407636661116077143	1157040657040363676	10100	17566520	56131367
46.	1137431557133151004	1222265021477405004	10100	00337753	37445206
47.	1113003456475500265	0314661556545362364	00110	00535125	64207534
48.	1746553632646152413	0177320240371640542	00110	13453151	56777170
49.	1465416631251321074	0735517310345570340	00110	21562617	04565002
50.	0130516430377202712	1367565551220511432	10100	06143774	47205720
51.	0762173527246302776	1274167141162675644	10100	02423654	40551334
52.	1606732407336425136	1543641015130470077	10100	37356552	07350575
53.	1131112010066741562	0640733734534576460	00110	26333436	42610757
54.	1107467740060732403	0216312531021205434	10100	41530037	71737010

55.	0755500241327076744	0050232164401566177	00110	16717444	75645017
56.	1443037764170374631	0702636370401726111	10100	65315205	30602344
57.	0243224434357700345	1733537351460015703	00110	61663615	13033027
58.	0445504023027564357	1523265651140460620	00110	71255331	43731073
59.	1211152271373271472	0607703231502460135	10100	61150443	54235167
60.	0256644102553071753	1757246242710445777	10010	33670743	75030422
61.	0733312314424771412	0464412467237572274	10001	60241113	36771756
62.	1636376400221406415	1050617751566552643	11000	23000162	57362200
63.	0574114621235461516	1041606123021052264	00110	56376246	37046217
64.	1710717574016037362	1335441345250455042	10100	04446544	53062337

NOTE –

*Bits in the initial conditions for R0 and R1 registers are read from left to right and left most bit is the first bit of the initial condition.

The initial conditions are in octal representation for each Satellite Vehicle (SV) signal. To derive octal notation the first MSB from left is represented as one symbol. In the octal notation, the last 18 symbols are the conventional octal representation of the remaining 54 chips.

For example-

(0072276243316574510)octal =

(0000111010010111110010100011011001110101111100101001000)binary.

**The initial and the final 24 bit values are obtained by conventional octal representation

The initial 24 bits are given as n_1, n_2, \dots, n_{24} for each SV signal. Bits are read from left to right and left most bit is the first chip of the code.

For example (06645560)octal =(000110110100101101110000)bin

Table 8:L1 Band SPS IZ4 Pilot PRN codes for PRN IDs 1 to 64

PRN ID	Initial Conditions for R0 , R1 and C Shift Registers for Primary Pilot IZ4 codes			First and Last 24 chip pattern for Primary Pilot IZ4 codes	
	Initial Condition for R0 Shift Register in Octal (R0(0) to R0(54))	Initial Condition for R1 Shift Register in Octal (R1(0) to R1(54))	Initial Condition for C Register (Binary) for Pilot Codes C(0) to C(4)	First 24 bit (Octal)	Last 24 bit (Octal)
1.	0227743641272102303	1667217344450257245	01000	53740552	72013372
2.	0603070242564637717	0300642746017221737	00000	14032136	55110050
3.	0746325144437416120	0474006332201753645	01000	03210111	32550562

4.	0023763714573206044	0613606702460402137	00000	30570334	50067422
5.	0155575663373106723	1465531713404064713	01000	43675670	02216745
6.	0022277536552741033	1063646422557130427	01000	63562125	17556634
7.	0137757627072411730	1066060465055002004	00000	43303023	14533530
8.	0413034001670700216	0225574416605070652	01000	31677424	03200565
9.	0501123675324707024	1733560674073230405	00000	75567033	35024412
10	0013727517464264567	1116277147142260461	00000	44713746	05025224
11	0663351450332761127	0152604753526345370	00000	06530236	01613756
12	1450710073416110356	1110300535412261305	01000	64004221	41236174
13	1716542347100366110	1046105227571557243	01000	62714055	23223101
14	0743601273016301212	1020346561064461527	00000	41016327	16677630
15	1454332372150500137	1270052747201123510	00000	53402536	34026353
16	1473215015316613621	1041553307136735706	00000	42066554	77017771
17	1255535602164437613	1002352163603013730	01000	60506703	03354630
18	1164537254033266174	1362622514254366256	01000	77521320	12726136
19	1500537251137244274	0556645716623157361	01000	06322070	47127337
20	0766727150471256024	0020341533300021636	01000	21406261	40120412
21	0457637114652202460	1470231623730254774	00000	63411471	51230750
22	0436500136253056124	1437100574634755567	01000	41354223	04625675
23	1666265767713037215	0215346037247347710	01000	30246105	20513134
24	1465272157164065443	1074246275146357122	00000	43612313	14006257
25	0607440357166466472	1655552356143710472	01000	52276712	21046123
26	1670202421463640077	1067241424131022656	00000	43352061	41635204
27	1312661744614412524	1611144345044137740	01000	50056012	03500532
28	1413034001672741216	1235122601654653275	00000	51645130	67615401

29	1113765722434040551	0663754302501454556	00000	33176614	37573550
30	0621573414133237134	0330540311241344370	00000	15426014	51075157
31	0526104310250410535	1763277034331577303	00000	77153741	67366210
32	0426454733176070600	1325110610226320770	01000	75654634	04521170
33	1440644676733136472	0632344657312671631	01000	11106036	25211541
34	0557275325702027456	1432530060077160315	00000	61525403	01443414
35	0657637150553356442	1272177170234542346	01000	73117543	41644751
36	1403560400557766512	0043174152003062273	01000	22557402	01274546
37	1531165662277124403	0633575650312403065	00110	25661731	11001616
38	1403072012721162611	0305021033755066410	00000	14241041	73623733
39	0541210077534050730	0137373436464572225	01010	21245724	16353110
40	1660256422576622574	0014331642301151614	00110	14513531	76306001
41	0646767375467672136	0444423305436737401	00101	30064076	65571401
42	1563301635027210017	0232343171540161113	10001	52577577	71335116
43	1403462012723163611	0101411166154322757	00110	10366504	61675504
44	0767233376550711053	0501120665453153342	00000	24045033	25103421
45	1260555130762307205	1042475051720150775	10001	01142272	06151115
46	0531075060147161624	1533531265037673325	00000	65565453	46260175
47	0112673710551347402	0506620200211067675	00110	30037153	15724521
48	1314750013607403146	1324133406103765602	00101	47040442	01155613
49	0471706447643213002	0203136107415235456	00110	04243647	77440117
50	0770352206645261362	1521524233172031026	10010	20147640	61152772
51	0255127616022236737	0164213410044443204	10001	44271150	37022745
52	1035616240477274125	1221110757557452411	00011	57107457	43403302
53	0251115713566666576	0252317630101475044	01000	32104575	37136235

54	0752241454312660541	0014540074363706135	00000	00626003	13260340
55	0461250256520434602	0371711523526255275	00000	17474465	10570111
56	1116341217327713444	0012400567546521471	00101	12765105	36304246
57	0765232132271554573	0312622351062337705	10001	57550526	66321515
58	0774370107303671123	0023647344743400250	00000	01172356	13671572
59	1407140711055577677	0257310611765747211	01000	32344634	63503523
60	1753355476331367516	1540176212407214706	00000	66007710	16233676
61	0101630163132222775	1412637164262406706	00000	60531747	27615217
62	0730471404057577456	0363125736302421243	10001	54124645	10154067
63	1336743247162047542	0414175374460515677	00000	20607657	27413550
64	0020666576373544533	0004500310276201661	01000	20634210	32200700

4.2 SECONDARY OVERLAY CODE GENERATOR ARCHITECTURE

The secondary or overlay code associated to each L1 pilot primary code has a length of 1800 chips. The overlay codes are independently, time synchronized, and 18 seconds in length at a rate of 100 bps. The overlay codes of length 1800 are generated by short cycling the Z4-linear codes of period 2046. The overlay codes are generated in a manner similar to the generation of the primary IZ4 codes. The components used to generate the overlay code are two ten-tap shift registers, labelled as R0 and R1 with specified feedback polynomial. The C register, used for primary code generation, is however, not required for overlay code generation.

Feedback for R0 shift register is calculated using R0 shift register taps only and for R1 register it is calculated using both R1 and R0 registers taps using the following equations:

$$\mathbf{R0(9)} = \mathbf{R0(5)} \oplus \mathbf{R0(2)} \oplus \mathbf{R0(1)} \oplus \mathbf{R0(0)} \quad \dots (21)$$

$$\mathbf{\sigma_{2A}} = [\mathbf{R0(5)} \oplus \mathbf{R0(2)}] \text{ AND } [\mathbf{R0(1)} \oplus \mathbf{R0(0)}] \quad \dots (22)$$

$$\mathbf{\sigma_{2B}} = [\mathbf{R0(5)} \text{ AND } \mathbf{R0(2)}] \oplus [\mathbf{R0(1)} \text{ AND } \mathbf{R0(0)}] \quad \dots (23)$$

$$\mathbf{\sigma_2} = \mathbf{\sigma_{2A}} \oplus \mathbf{\sigma_{2B}} \quad \dots (24)$$

$$\mathbf{R1A} = \mathbf{\sigma_2} \oplus \mathbf{R0(6)} \oplus \mathbf{R0(3)} \oplus \mathbf{R0(2)} \oplus \mathbf{R0(0)} \quad \dots (25)$$

$$\mathbf{R1B} = \mathbf{R1(5)} \oplus \mathbf{R1(2)} \oplus \mathbf{R1(1)} \oplus \mathbf{R1(0)} \quad \dots (26)$$

$$\mathbf{R1(9)} = \mathbf{R1A} \oplus \mathbf{R1B} \quad \dots (27)$$

In equation (21), the quantity $R0(9)$ being computed, represents the contents $R0(t+1,9)$ of the 10th tap of register $R0$ at time $(t+1)$, whereas the quantities on the right in equation (21), are quantities computed at time t . Similarly in equation (27), the quantities on the right are computed at time t , whereas the quantity on the left, $R1(9)$ represents the contents $R1(t+1,9)$ of the 10th tap of Register $R1$ at time $(t+1)$. At time $t=0$, all registers are initialized with the initial conditions stored in memory. A unique pair of $R0$ and $R1$ register initial conditions uniquely determines the generated overlay code. Figure 12 shows the block diagram of the overlay sequence generator.

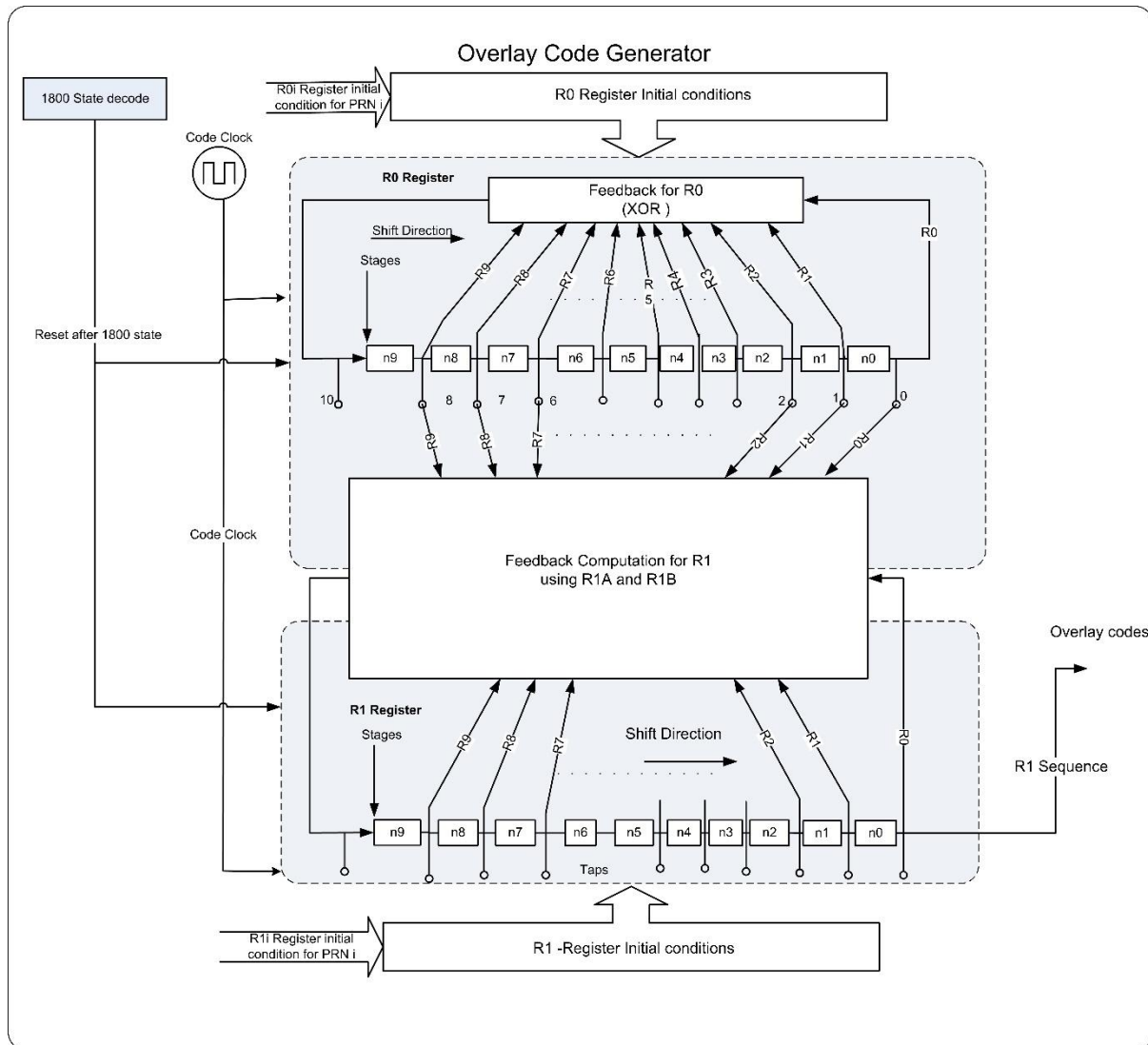

Figure 12: Block Diagram of overlay sequence generator

The specific parameters of the secondary overlay codes of the L1 pilot components are shown in Table 9.

Table 9: Initial conditions of R0 and R1 shift registers, initial and last 24 chips of the Pilot Overlay Codes

PRN ID	Initial conditions for Overlay R0 Shift Register (in binary)	Initial conditions for Overlay R1 Shift Register (in binary)	First 24 chips (in octal)	Last 24 chips (in octal)
1.	0110111011	0100110000	23021014	60003002
2.	0111101000	0110000010	30111146	11105073
3.	1100000001	1110010001	71054172	72662343
4.	0110110110	0101110011	27145543	24522305
5.	0100011000	1011000110	54300755	40652542
6.	0011111100	1010101111	52741330	36171020
7.	0001100101	1110001000	70406424	60100641
8.	1111000101	0001010000	05035447	67256475
9	0011001100	1011111100	57602345	11535072
10.	1000011010	0100010101	21274713	36034630
11.	0001001001	1100000100	60216711	65200130
12.	0110101011	0111011110	35715557	01701172
13.	0101110000	1001110011	47157052	30275773
14.	0010110011	1001101010	46534500	46573506
15.	1110000111	0001100101	06262501	40735727
16.	1000000000	0101101000	26411564	44632770
17.	1111101101	0111111011	37545377	74020217
18.	1111101011	1001110001	47063313	27043077
19.	0010001011	1101011001	65464432	43020576

20.	0011101000	0111011110	35710754	64623273
21	0011011010	0011100101	16260170	65732773
22	0011111100	1101000001	64043133	71431000
23	0111001100	0110110001	33071063	76435202
24	1000101110	0011000001	14066574	65555757
25	0101000010	1111100001	76041515	57026606
26	0000101010	0010011011	11574654	57071554
27	0000100001	0110011110	31726225	60642500
28	1000010000	0000111000	03433152	43112243
29	1011100100	0000000101	00245223	44770110
30	0110111111	0000100100	02227243	77464417
31	1001110000	0110101101	32671744	63001440
32	1101110101	1011010001	55054314	16430204
33	0101111100	0001110111	07341200	33302042
34	1011001000	0110100111	32365557	04711127
35	1000001100	0111010101	35267034	66447657
36	0001100101	1110110101	73276604	34654643
37	0000000010	1011110110	57324224	54711375
38	0010100011	1011011010	55503225	21536155
39	1111010010	1100101010	62536764	25437220
40	0000100101	1101101111	66754655	64201747
41	0100111011	1110011111	71745110	70015212
42	0110111001	1000100000	42016534	46403730

43	0010011101	0110000101	30266560	14726700
44	1000011010	0101111101	27674106	06625521
45	0010000010	0011110111	17360651	52373274
46	1001001111	1010001010	50537616	33270326
47	1111001111	1101000011	64171306	46071732
48	0010110010	1101101101	66641510	67553453
49	0111111110	1011101001	56456324	03625012
50	0100100011	0100001100	20624551	00524027
51	0100001110	1001100010	46104673	46212352
52	0111101101	1100110011	63177256	21612123
53	1000010010	0011110101	17243034	04750576
54	1001001110	0100110100	23223001	34056627
55	0001011110	1110011000	71402404	17716150
56	1110001001	1000111100	43614767	00453055
57	1110110001	0100010000	21001344	50355624
58	1101111110	0010011101	11650534	51327047
59	0111111000	1100011010	61530760	32055331
60	1010001111	0010011000	11403654	30331624
61	1100110100	0001001000	04413664	11310116
62	0011010010	0110001110	30731752	56014440
63	1101010100	0110101101	32675306	43410343
64	1001110110	1100011011	61550413	16144102

Figures 13 ,14 and15 below, explain the feedback computation for R0 and R1 shift registers for overlay codes. Figure 13 illustrates how the feedback for Register R0 as well as how some components of the feedback for Register R1 can be carried out. The output of Register R1 is

the overlay code. Quantities on the left such as R0(5) in the topmost sub-figure in Figure 13, represent contents of the respective registers at time t, whereas the quantity R0(9) on the right, represents the contents R0(t+1,9) of Register R0(9) at time (t+1).

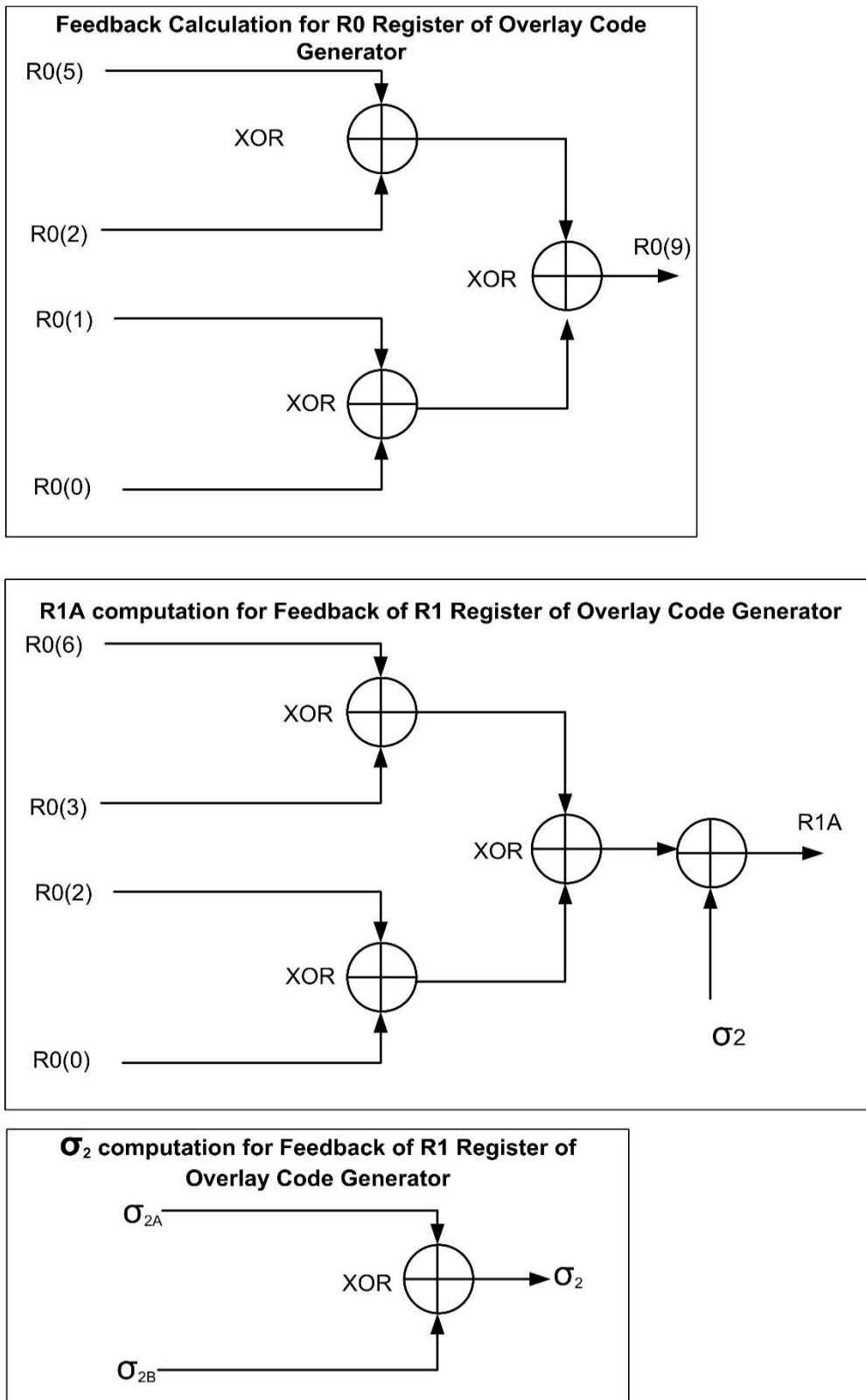

Figure 13: Feed Back Computation for R0 and R1A determination for overlay codes

σ_{2A} and σ_{2B} Computation for Overlay Codes

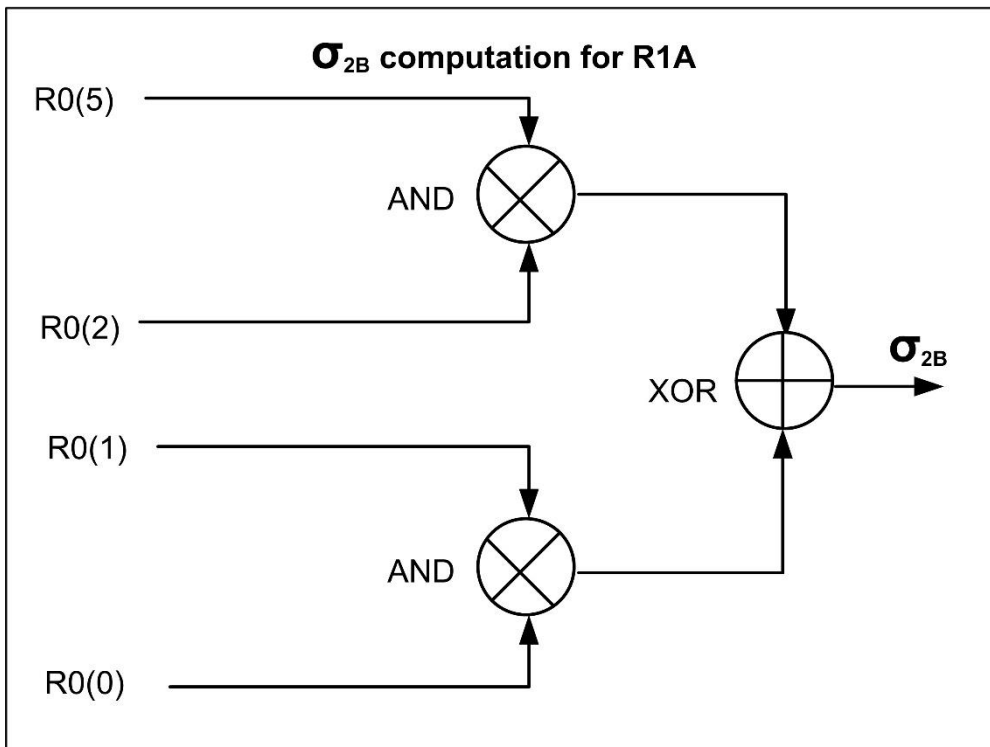
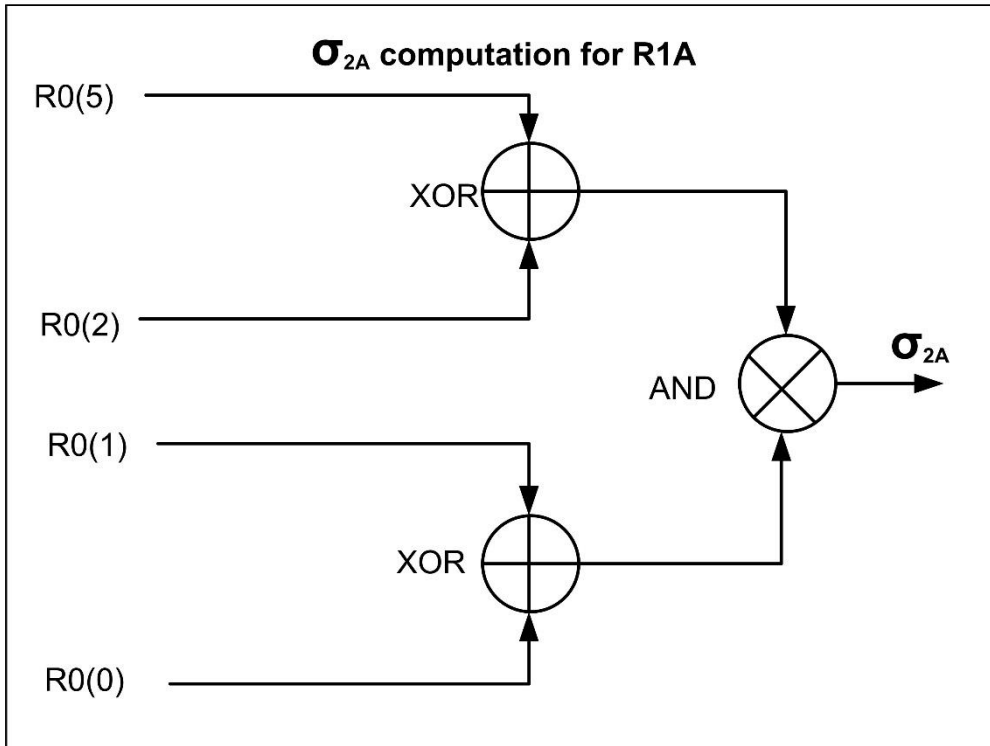

Figure 14: σ_{2A} and σ_{2B} computation for overlay codes

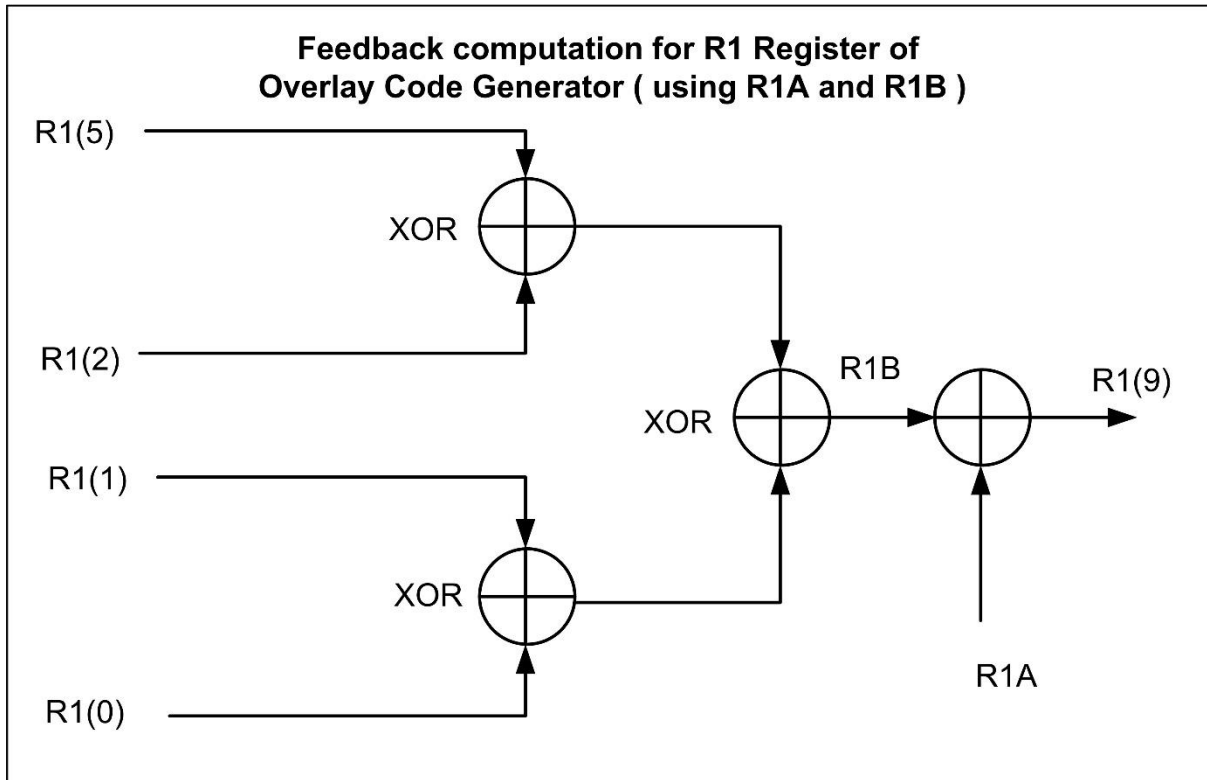

Figure 15: R1 Register feedback computation for overlay codes

5 L1 SPS DATA STRUCTURE

NavIC Signal-In-Space transmits Navigation message contents on SPS service, in L1 band. The NavIC L1 Master frame comprises of 3 Sub-frames. The sub-frame structure is shown in Figure 16 below.

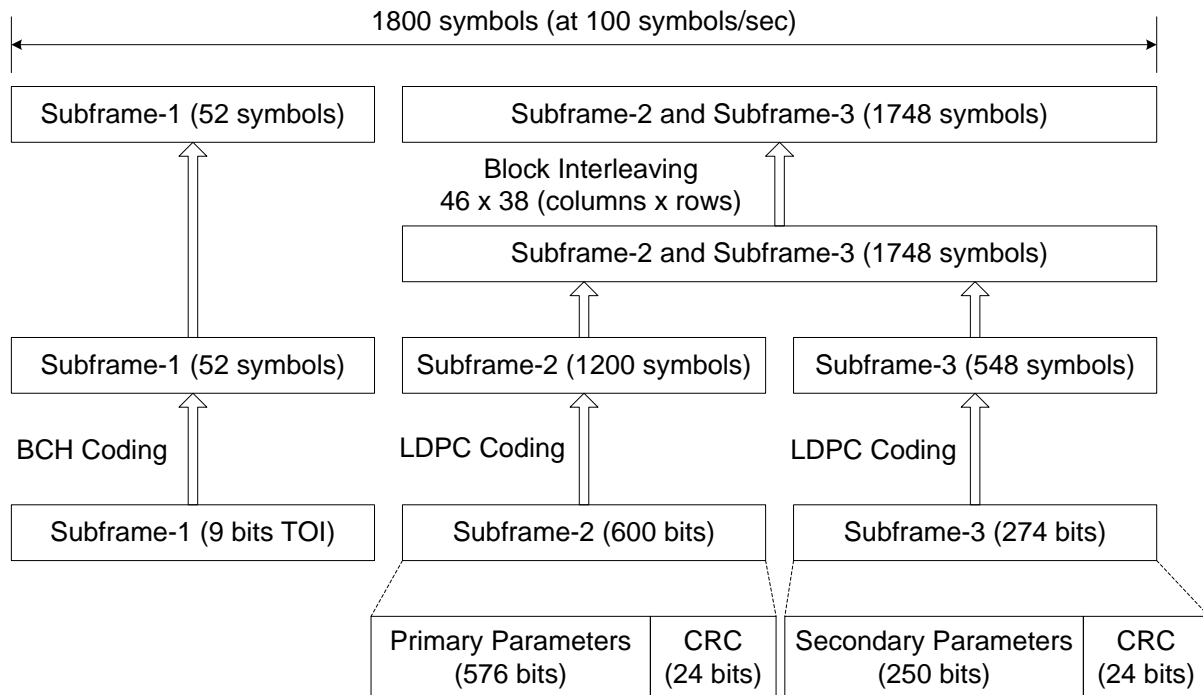

Figure 16 : NavIC L1 SPS Subframe Structure

The 9 bits of subframe-1 is Bose, Chaudhuri, and Hocquenghem (BCH) encoded. The 600 bits of subframe-2 and 274 bits of subframe-3 are Low Density Parity Check (LDPC) Forward Error Correction (FEC) encoded and interleaved as shown in the Figure 16 above.

5.1 BIT AND BYTE ORDERING CRITERIA

The following bit and byte ordering criteria will be used while formatting the navigation data:

- The most significant bit/byte is numbered as bit/byte 1
- The most significant bit/byte is transmitted first

5.2 BCH CODING

Nine bits of TOI data are channel encoded using BCH (52, 9) code. The nine-bit time of interval (TOI) data are encoded using the generator polynomial of 1767 (octal). This code generator is conceptually described in Figure 17 below using an 9-stage linear shift register generator. TOI data bits 1 to 9 are loaded into the generator, Most Significant Bit (MSB) first, as initial conditions of the registers, which is then shifted 52 times to generate 52 encoded symbols.

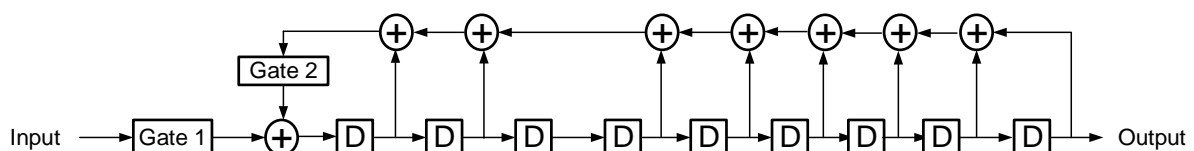

Figure 17 : Diagram of the BCH Encoder Circuit

The generator polynomials of these BCH encoders are shown in Table 10 below.

The BCH (n, k) encoders are implemented by using the k-stage registers as shown in Figure 17 above. Gate 1 is closed during the first k clock periods and then disconnected; the gate 2 is disconnected during the first k periods and then closed.

The decoding of BCH encoded signal at receiver can be done with generating the replica code words using a linear shift register (LSRG) with the requisite feedback connections. It can then perform maximum-likelihood decoding by correlating the stored received soft decisions of the coded bits against all possible candidate TOI code words.

Table 10: Generator polynomials of BCH encoders

BCH Code	Encoding Characteristics			Generator Polynomials (g(x))
	n	k	d _{min}	
(52, 9)	52	9	20	$x^9+x^8+x^7+x^6+x^5+x^4+x^2+x+1$

5.3 LOW DENSITY PARITY CHECK ENCODING

Subframe-2 and subframe-3 are separately encoded using rate ½ Quasi Cyclic LDPC codes. Subframe-2 has a total of 600 bits consisting of 576 bits for primary navigation parameters and 24 bits for CRC. Subframe-3 has a total of 274 bits consisting of 250 bits for secondary navigation parameters and 24 bits for CRC. As a result of rate ½ Quasi Cyclic LDPC encoding, there are 1200 symbols (coded bits) for subframe-2 and 548 symbols for subframe-3 as described in Figure 16.

The LDPC encoder structure is based on a parity-check matrix H(m, n) of m rows and n columns. For subframe-2, m = 600, n = 1200 and for subframe-3, m = 274, n = 548 are selected. The LDPC matrix H is assumed as approximate lower triangular form and having the dual diagonal structure. H(m,n) is further decomposed into 6 submatrices A, B, T, C, D, and E as shown in Figure 18 below. Each element of matrix H(m, n) is either a value of “0” or “1”.

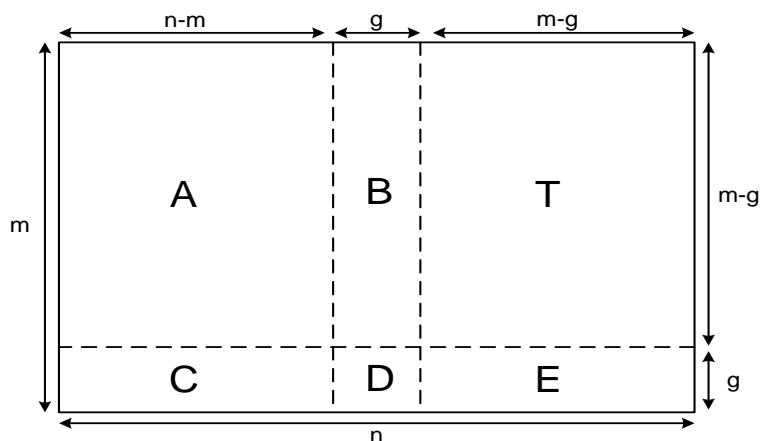

Figure 18: Parity-check matrix H and its sub-matrix size

Tables 29 to 34 define the coordinates of elements with value “1” in each of the submatrices A, B, C, D, E, and T, respectively, for subframe-2.

Tables 35 to 40 shall define the coordinates of elements with value “1” in each of the submatrices A, B, C, D, E, and T, respectively, for subframe-3

The inverse of T is not included in this document. However T is a lower triangular matrix and therefore, the inverse of T can be easily identified.

The rate 1/2 LDPC encoder shall use the given matrices A, B, T, C, D and E to generate the encoded symbols using the following algorithm:

$$p_1^t = -\varphi^{-1} \cdot (-E \cdot T^{-1} \cdot A + C) \cdot s^t$$

$$p_2^t = -T^{-1} \cdot (A \cdot s^t + B \cdot p_1^t)$$

where,

$$\varphi = -E \cdot T^{-1} \cdot B + D,$$

s = subframe 2 and subframe 3 data,

x^t - indicates transpose,

and elements of matrices p_1 and p_2 are modulo 2 numbers.

The encoded symbols for broadcast are comprised of $(s; p_1; p_2)$ where s is the systematic portion of the codeword, and $\{p_1, p_2\}$ comprise the combined parity bits.

5.3.1 LDPC Submatrices

The coordinates of elements with value “1” in each of the submatrices specified in section 5.3 are provided in Appendix J.

Tables 29 to 34 define the coordinates of elements with value “1” in each of the submatrices A, B, C, D, E, and T, respectively, for subframe-2.

Tables 35 to 40 shall define the coordinates of elements with value “1” in each of the submatrices A, B, C, D, E, and T, respectively, for subframe-3

Tables 41 to 46 define number of “1”s in each of the rows and columns A, B, C, D, E, and T, respectively, for subframe-2.

Tables 47 to 52 define number of “1”s in each of the rows and columns A, B, C, D, E, and T, respectively, for subframe-3.

Due to large amount of information provided in some of the submatrix tables, supplemental information is also provided in Appendix J. The supplemental information tables provide the number of 1’s in each row and column of submatrices A to T for subframe-2 and subframe-3

5.4 INTERLEAVING

The 1748 symbols of LDPC encoded navigation data of subframe-2 and subframe-3 is interleaved using a block interleaver with n columns and k rows. Data is written in columns and then, read in rows. The Table 11 below indicates the interleaving mechanism.

Table 11: Interleaving parameters

Parameter	Arrangement
Block Interleaver size	1748
Block Interleaver Dimensions (n columns x k rows)	46 x 38

5.5 CYCLIC REDUNDANCY CHECK (CRC)

The data signal contains parity coding according to the following conventions. CRC – 24Q polynomial shall be used for each Sub frame. Twenty-four bits of CRC parity will provide protection against burst as well as random errors with a probability of undetected error $\leq 2^{-24} = 5.96 \times 10^{-8}$ for all channel bit error probabilities ≤ 0.5 .

The generator polynomial is given as,

$$g(X) = \sum_{i=0}^{24} g_i X^i$$

where,

$$g_i = 1, \text{ for } i = 0, 1, 3, 4, 5, 6, 7, 10, 11, 14, 17, 18, 23, 24$$

$$= 0, \text{ otherwise}$$

5.6 NavIC SYSTEM TIME

The NavIC system time is given as 30-bit binary number composed of three parameters as follows:

The Week Number is an integer counter that gives the sequential week number from the origin of the NavIC time. This parameter is coded on 13 bits appearing in the second subframe, which covers 8192 weeks.

The Interval Time of Week (ITOW), represented in 8 bits, identifies the start time of the 2 hour interval since the beginning of the NavIC week.. This parameter appears in Subframe 2.

Time of Interval (TOI) is the count of the number of 18 sec message intervals in each 2 hour ITOW. The TOI is represented in 9 bits. This parameter appears in Subframe 1.

The NavIC System Time start epoch shall be 00:00 UT on Sunday August 22nd 1999 (midnight between August 21st and 22nd). At the start epoch, NavIC System Time shall be ahead of UTC by 13 leap seconds. (i.e. NavIC time, August 22nd 1999, 00:00:00 corresponds to UTC time August 21st 1999, 23:59:47)

5.7 COORDINATE SYSTEM

The NavIC system uses WGS 84 coordinate system for the computation of user position.

5.8 FRAME STRUCTURE

The NavIC L1 Master Frame is of 1800 symbols long made of three sub frames. The master frame structure is shown in Figure 19.

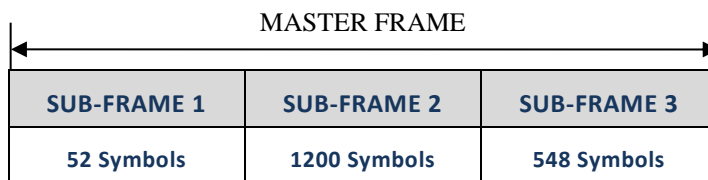

Figure 19: Master Frame Structure

5.8.1 Sub Frame Structure

The details of each sub-frame are given in this section. Overall details of each sub frame symbol generation scheme is shown in Figure 16.

5.8.1.1 Primary Data Subframe-1

Sub frame 1, as shown in Figure 20, transmits TOI (Time-Of-Information).



Figure 20: Sub-frame 1 Layout

5.8.1.2 Primary Data Subframe-2

Sub frame 2, as shown in Figure 21, transmits primary navigation data..

1	14	22	23	571	577
WN	ITOW	ALERT	DATA	PRN ID	CRC
13 BITS	8 BITS	1 BIT	548 BITS	6 BITS	24BITS

Figure 21: Sub-frame 2 Layout

5.8.1.3 Primary Data Subframe-3

Sub-frame 3, as shown in Figure 22, transmits navigation parameters as Messages. It identifies the message types that the NavIC satellites will transmit. Provision exists to define new

messages for future requirements in NavIC. Each message is identified by a unique message identifier.

1	7	8	251
MESSAGE ID	INVALID DATA FLAG	MESSAGE DATA	CRC
6 BIT	1 BIT	243 BITS	24 BITS

Figure 22: Sub-frame 3 Layout

5.9 NAVIGATION DATA

The navigation data (NAV data) includes NavIC satellite ephemeris, NavIC time, satellite clock correction parameters, status messages and other secondary information etc. Navigation data modulated on top of the ranging codes can be identified as primary and secondary navigation parameters

5.9.1 Primary Navigation Parameters

- Satellite Ephemeris
- Satellite clock correction parameters
- Satellite & signal health status
- Inter-signal Correction
- User Range Accuracy
- Total group delay

5.9.2 Secondary Navigation Parameters

- Satellite almanac
- Ionospheric grid delays and confidence
- NavIC Time Offsets with respect to UTC & other GNSS
- Ionospheric delay correction coefficients
-Klobuchar like
- Text messages
- Earth orientation parameters

5.9.3 Idle Pattern

Under certain conditions Idle Pattern containing alternating zeroes and ones is transmitted in the data part of the navigation sub-frames of NavIC. Idle pattern shall begin from bit 23 in sub-frame 2, and from bit 8 in sub-frame 3, the first bit being a zero. An idle pattern in Sub-frame 2 is accompanied by an Alert flag set to 1 and a valid CRC for the sub-frame. An idle pattern in Sub-frame 3 is accompanied by an Invalid data flag set to 1 and a valid CRC for the sub-frame. An idle pattern of all ‘1’s will be transmitted in Subframe-1, i.e. all ‘1’s in Time Of Interval (TOI), under certain conditions.

6 SUBFRAME STRUCTURE

The Time of Interval is transmitted in Subframe 1. The primary navigation parameters are transmitted in Subframe 2. Subframe 3 caters to the transmission of secondary navigation parameters viz. ionosphere grid corrections, almanac, NavIC time offsets with respect to UTC and other GNSS, klobuchar like ionosphere coefficients, Earth orientation parameters, and text messages. The secondary navigation parameters are transmitted in the form of messages.

6.1 SUBFRAME DATA FORMAT

6.1.1 Subframe 1 Data Format

The sub-frame 1 transmits the Time of interval (TOI) value. Table 12 defines the parameter and the notation used.

Table 12: Sub frame 1 data format

S. No	Parameter	Notation	Scale Factor	Size (Bits)	Start Bit	End Bit	Units
1	Time of Interval	TOI	18	9	1	9	seconds

6.1.2 Subframe 2 Data Format

The sub-frame 2 transmits the primary navigation parameters. Table 13 defines the parameters and the notations used.

Table 13: Sub frame2 data format

S.No	Parameter	Notation	Scale Factor	Size (Bits)	Start Bit	End Bit	Units
1	L1sps Health	-	1	1	23	23	-
2	Issue of Data	IOD	1	4	24	27	-
3	URA Index	URAI	1	5*	28	32	-
4	Time of Ephemeris and clock	toEC	300	11	33	43	seconds
5	Semi-Major Axis Difference at Reference Time	ΔA	2^{-9}	26*	44	69	meters
6	Change Rate in Semi-Major Axis	\dot{A}	2^{-21}	26*	70	95	meter/sec
7	Mean motion Difference at Reference Time	Δn_0	2^{-44}	19*	96	114	semi-circle/sec
8	Rate of Mean Motion Difference	$\Delta \dot{n}$	2^{-57}	23*	115	137	semi-circle/sec ²
9	Mean Anomaly at reference time	M_0	2^{-32}	33*	138	170	semi-circles

10	Eccentricity	e	2^{-34}	33	171	203	-
11	Argument of Perigee	ω	2^{-32}	33*	204	236	semi-circles
12	Longitude of Ascending Node at Weekly Epoch	Ω_0	2^{-32}	33*	237	269	semi-circles
13	Rate Of Right Ascension	$\dot{\Omega}$	2^{-44}	25*	270	294	semi-circle/sec
14	Inclination Angle at Reference Time	i_0	2^{-32}	33*	295	327	semi-circles
15	Rate of Inclination	IDOT	2^{-44}	15*	328	342	semi-circle/sec
16	Amplitude of the sine harmonic correction term to the angle of inclination	C_{is}	2^{-30}	16*	343	358	rad.
17	Amplitude of the cosine harmonic correction term to the angle of inclination	C_{ic}	2^{-30}	16*	359	374	rad.
18	Amplitude of the sine correction term to the orbit radius	C_{rs}	2^{-8}	24*	375	398	meters
19	Amplitude of the cosine correction term to the orbit radius	C_{rc}	2^{-8}	24*	399	422	meters
20	Amplitude of the sine harmonic correction term to the argument of latitude	C_{us}	2^{-30}	21*	423	443	rad.
21	Amplitude of the cosine harmonic correction term to the argument of latitude	C_{uc}	2^{-30}	21*	444	464	rad.
22	Clock Bias	a_{f0}	2^{-35}	29*	465	493	seconds
23	Clock Drift	a_{f1}	2^{-50}	22*	494	515	sec/sec
24	Clock Drift Rate	a_{f2}	2^{-66}	15*	516	530	sec/sec ²

25	Total Group Delay	TGD	2^{-35}	12*	531	542	seconds
26	Inter-Signal Correction for L1 Pilot (RSF=1) or Inter-Signal Correction for S (RSF=0)	ISC _{LIP} or ISC _S **	2^{-35}	12*	543	554	seconds
27	Inter-Signal Correction for L1 Data	ISC _{LID}	2^{-35}	12*	555	566	seconds
28	Reference Signal Flag	RSF**	1	1	567	567	-
29	Spare	Spare	-	3	568	570	-

* Parameters indicated are 2's complement.

** Based on the RSF flag, respective ISC's will be transmitted (Refer Appendix C); That is, if RSF =1, ISC_{LIP} will be broadcasted; if RSF =0, ISC_S will be broadcasted;

6.1.3 Subframe 3 Data Format

Sub-frame 3 transmits navigation parameters and need based information as Messages. Table 14 identifies the message types that the NavIC satellites will transmit on SPS L1 signal. Each message is identified by a unique message identifier. Each message transmits 243 bits of Navigation data.

Table 14: NavIC SPS L1 Signal Message Types

PARAMETER	MSG ID
Ionosphere grid parameters	5
Almanac	6
Reserved for New Iono Message	8
Klobuchar like Ionosphere coefficients & EOP	10
NavIC Time offsets w.r.t UTC and other GNSS	17
Null Message	0
Reserved Messages	1-4,7,9,11-16,18-63

6.1.3.1 Message Type 5 Data Format

Message Type 5 transmits the ionospheric grid corrections in the form of GIVEI and GIVD for one region. Thus, 6 messages of message type 5 (one for each region with 15 IGPs) together provide the complete set of ionospheric grid based parameters for Indian region. Table 15 defines the parameters and the notations used in Message Type 5.

Table 15: Message Type 5 format

Parameter	Scale Factor	Size (bits)	Start Bit	End Bit	Units
Regions Masked	-	10	8	17	-
Region Id	-	4	18	21	-
GIVEI	-	4	22	25	-
GIVD	0.125	9	26	34	meters
GIVEI	-	4	35	38	-
GIVD	0.125	9	39	47	meters
GIVEI	-	4	48	51	-
GIVD	0.125	9	52	60	meters
GIVEI	-	4	61	64	-
GIVD	0.125	9	65	73	meters
GIVEI	-	4	74	77	-
GIVD	0.125	9	78	86	meters
GIVEI	-	4	87	90	-
GIVD	0.125	9	91	99	meters
GIVEI	-	4	100	103	-
GIVD	0.125	9	104	112	meters
GIVEI	-	4	113	116	-
GIVD	0.125	9	117	125	meters
GIVEI	-	4	126	129	-
GIVD	0.125	9	130	138	meters
GIVEI	-	4	139	142	-
GIVD	0.125	9	143	151	meters
GIVEI	-	4	152	155	-
GIVD	0.125	9	156	164	meters
GIVEI	-	4	165	168	-
GIVD	0.125	9	169	177	meters
GIVEI	-	4	178	181	-
GIVD	0.125	9	182	190	meters
GIVEI	-	4	191	194	-
GIVD	0.125	9	195	203	meters
GIVEI	-	4	204	207	-
GIVD	0.125	9	208	216	meters
IODI	-	3	217	219	-
Spare	-	31	220	250	-

6.1.3.2 Message Type 6 Data Format

Each message type 6 contains the almanac of one NavIC satellite. Table 16 defines the parameters and the notations used in Message Type 6.

Table 16: Message Type 6 format

Parameter	Notation	Scale Factor	Size (bits)	Start Bit	End Bit	Units
Week number for almanac	WN_a	-	13	8	20	-
Eccentricity	E	2^{-21}	20	21	40	-
Time of almanac	t_{oa}	2^4	16	41	56	sec
Inclination	i_0	2^{-23}	24*	57	80	semi-circles
Rate of RAAN	$\dot{\Omega}$	2^{-38}	19*	81	99	semi-circles/sec
SQRT A	\sqrt{A}	2^{-11}	24	100	123	\sqrt{meters}
Longitude of ascending node(LAN)	Ω_0	2^{-23}	24*	124	147	semi-circles
Argument of perigee	Ω	2^{-23}	24*	148	171	semi-circles
Mean anomaly	M_0	2^{-23}	24*	172	195	semi-circles
Clock bias A0	a_{f0}	2^{-20}	14*	196	209	sec
Clock drift A1	a_{f1}	2^{-38}	11*	210	220	sec/sec
PRN ID for Almanac	PRN ID	-	6	221	226	-
Spare	-	-	24	227	250	-

* Parameters indicated are 2's complement.

6.1.3.3 Message Type 8 Data Format

(Reserved)

6.1.3.4 Message Type 10 Data Format

Message type 10 contains the Klobuchar like ionospheric coefficients and Earth orientation parameters. Table 17 defines the parameters and the notations used in Message Type 10.

Table 17: Message type 10 format

Parameter	Notation	Scale Factor	Size (bits)	Start Bit	End Bit	Units
EARTH ORIENTATION PARAMETERS						
EOP Data Reference Time	t_{EOP}	2^4	16	8	23	sec
X-Axis Polar Motion Value at Reference Time.	PM_X	2^{-20}	21*	24	44	arc-sec
X-Axis Polar Motion Drift at Reference Time.	$PM_{\dot{X}}$	2^{-21}	15*	45	59	arc-sec/day
Y-Axis Polar Motion Value at Reference Time.	PM_Y	2^{-20}	21*	60	80	arc-sec
Y-Axis Polar Motion Drift at Reference Time.	$PM_{\dot{Y}}$	2^{-21}	15*	81	95	arc-sec/day
UT1-UTC Difference at Reference Time.	$\Delta UT1$	2^{-24}	31*	96	126	sec
Rate of UT1-UTC Difference at Reference Time.	$\Delta \dot{U}T1$	2^{-25}	19*	127	145	sec/day
KLOBUCHAR LIKE IONOSPHERE COEFFICIENTS						
Alpha 0	α_0	2^{-30}	8*	146	153	sec
Alpha 1	α_1	2^{-27}	8*	154	161	sec/semi-circle
Alpha 2	α_2	2^{-24}	10*	162	171	sec/(semi-circle) ²
Alpha 3	α_3	2^{-24}	12*	172	183	sec/(semi-circle) ³
Beta 0	β_0	2^{11}	8*	184	191	sec
Beta 1	β_1	2^{14}	8*	192	199	sec/semi-circle
Beta 2	β_2	2^{16}	11*	200	210	sec/(semi-circle) ²
Beta 3	β_3	2^{16}	14*	211	224	sec/(semi-circle) ³
Maximum Longitude limit	$\lambda_{k_{max}}$	10	6	225	230	degree
Minimum Longitude limit	$\lambda_{k_{min}}$	10	6	231	236	degree
Maximum Latitude limit	$\phi_{k_{max}}$	10	5*	237	241	degree
Minimum Latitude limit	$\phi_{k_{min}}$	10	5*	242	246	degree
Issue Of Data Ionosphere with Klobuchar	IODK	1	2	247	248	-
Spare	-	-	2	249	250	-

* Parameters indicated are 2's complement

6.1.3.5 Message Type 17

Message Type 17 provides the NavIC time offset with respect to UTC, UTC (NPLI) and other GNSS like GPS, GALILEO and GLONASS. Table 18 defines the parameters and the notations used in Message Type 17

Table 18: Message Type 17 format

Parameter	Notation	Scale Factor	Size (Bits)	Start Bit	End Bit	Units
Issue of Data Time	IODT	1	3	8	10	
Time data reference time of week UTC/GNSS	t_{ug}	3600	8	11	18	Sec
Time data reference week number UTC/GNSS	WN_{ug}	1	13	19	31	week
Current or past leap second count	Δt_{LS}	1	8*	32	39	sec
Leap second reference week number	WN_{LSF}	1	13	40	52	week
Leap second reference day number	DN	1	4	53	56	days
Current or future leap second count	Δt_{LSF}	1	8*	57	64	sec
Bias coefficient of NavIC time scale relative to UTC time scale	A_{0utc}	2^{-35}	16*	65	80	sec
Drift coefficient of NavIC time scale relative to UTC time scale	A_{1utc}	2^{-51}	13*	81	93	sec/sec
Drift rate coefficient of NavIC time scale relative to UTC time scale	A_{2utc}	2^{-68}	7*	94	100	sec/sec ²
Valid Flag for UTC(NPLI)	-	1	1	101	101	-
Bias coefficient of NavIC time scale relative to UTC(NPLI) time scale	A_{0npli}	2^{-35}	16*	102	117	sec
Drift coefficient of NavIC time scale relative to UTC(NPLI) time scale	A_{1npli}	2^{-51}	13*	118	130	sec/sec
Drift rate coefficient of NavIC time scale relative to UTC(NPLI) time scale	A_{2npli}	2^{-68}	7*	131	137	sec/sec ²
GNSS ID 1	GNSSID	1	3	138	140	-
Valid Flag for GNSS ID 1	-	1	1	141	141	-
Bias coefficient of NavIC time scale relative to GNSS time 1	A_{0gnss}	2^{-35}	16*	142	157	sec
Drift coefficient of NavIC time scale relative to GNSS time 1	A_{1gnss}	2^{-51}	13*	158	170	sec/sec
GNSS ID 2	GNSSID	1	3	171	173	-
Valid Flag for GNSS ID 2	-		1	174	174	-
Bias coefficient of NavIC time scale relative to GNSS time	A_{0gnss}	2^{-35}	16*	175	190	sec

Drift coefficient of NavIC time scale relative to GNSS time	A_{1gnss}	2^{-51}	13*	191	203	sec/sec
GNSS ID 3	GNSSID	1	3	204	206	
Valid Flag for GNSS ID 3	-		1	207	207	-
Bias coefficient of NavIC time scale relative to GNSS time	A_{0gnss}	2^{-35}	16*	208	223	sec
Drift coefficient of NavIC time scale relative to GNSS time	A_{1gnss}	2^{-51}	13*	224	236	sec/sec
Spare	-	-	14	237	250	-

* Parameters indicated are 2's complement.

6.2 DATA CONTENTS

6.2.1 Subframe 1 & Subframe 2

6.2.1.1 TOI (Time Of Interval)

The TOI count utilizes a 9-bit data word that represents SV time at the start of the next 18-second frame. The count represents the number of 18-second epochs that have occurred since the start of the two-hour period represented by ITOW count in the subframe 2 of the next 18-second frame. The TOI count range is from 1 (000000001) to 400 (110010000). The beginning epoch of a two-hour period shall correspond to a start of subframe 1 and TOI count one (000000001) shall correspond to the start of the next 18-second frame following the beginning of a two-hour period. The TOI data is nominally the same on all SVs (for those SVs that broadcast TOI data).

6.2.1.2 Week Number (WN)

The Week Number is an integer counter that gives the sequential week number from the origin of the NavIC time. NavIC Time is the reference time generated by IRNWT located at INC. This parameter is coded in 13 bits which covers 8192 weeks (about 157.53 years).

6.2.1.3 Interval Time Of Week(ITOW)

ITOW count defined as being equal to the number of two-hour epochs that have occurred since the transition from the previous week. The count is short-cycled such that the range of the ITOW-count is from 0 to 83 2-hour epochs (equaling one week) and is reset to zero at the end of each week. The ITOW-count's zero state is defined as that 2-hour epoch which is coincident with the start of the present week. The 00:00:00 hours on the UTC scale that is nominally referenced to the Greenwich Meridian. The occurrence of the "zero state epoch" may differ by a few seconds from 00:00:00 hours on the UTC scale since UTC is regularly corrected for leap seconds while NavIC time is continuous without such correction.

6.2.1.4 Alert Flag

The Alert flag when set to '1' signifies to the users that the utilization of navigation data from that particular satellite shall be at the user's own risk.

6.2.1.5 Clock Parameters

The clock coefficients (a_{f0} , a_{f1} and a_{f2}) transmitted as part of subframe 2 are used for NavIC time and clock corrections. These estimated corrections account for the deterministic Satellite clock error having characteristics of bias, drift and aging. Bias is the difference between a measured on-time pulse (signal) and a reference on-time pulse (signal) of NavIC System Time. Drift is the linear component of a systematic change in frequency of an oscillator over a period of time. It is caused by aging, by environmental changes and by other internal factors of the oscillator. Drift rate is the rate of change of drift. Time of clock, t_{oc} is the clock data reference time in seconds. The parameters are discussed in Appendix B.

6.2.1.6 Issue of Data Ephemeris & Clock (IODEC)

For NavIC L1-SPS, the IODEC is a 4-bit number which indicates the issue number of the data set and thereby provides the user with a convenient means of detecting any change in the ephemeris and clock parameters with same time of ephemeris/clock. Each time the user equipment is powered on, it must ensure that it is using up-to-date ephemeris and clock data for the satellites involved in its position computation.

The IODEC range assigned are defined in Table 19.

Table 19: IODEC Range

IODEC range	Update rate	Set Validity Period	Remarks
0 to 5	2 hours	4 hrs	-
6 to 9	15 minutes	30 mins	-
14 to 15	2 hours	6 hrs	Satellites store 7 days ephemeris and clock parameter sets as AutoNav data sets. Satellite can support broadcast of primary navigation parameters from AutoNav data sets with no uplink from ground for maximum of 7 days. During AutoNav the IODEC range is as mentioned.
10 to 13	-	Reserved	

6.2.1.7 Signal Health Flags

The one-bit L1 health flag indicates the health of navigation data signals as follows.

Table 20: Signal Health Flags

Flag	Value	Description
L1-SPS flag	0	All navigation data on L1-SPS signal are OK
L1-SPS flag	1	Some or all navigation data on L1-SPS signal are bad

6.2.1.8 User Range Accuracy (URA)

URA is a statistical indicator of the ranging accuracies obtained with a specific SV. URA is a one-sigma estimate of the user range errors in the navigation data for the transmitting satellite and its index value ranges from -16 to 15. The details on mapping between URA Index (URAI) and URA are provided in the following Table 21.

Table 21: URA Index to URA Mapping

URA Index	URA(meters)
15	$6144.00 < \text{URA}$ (no accuracy prediction is available)
14	$3072.00 < \text{URA} \leq 6144.00$
13	$1536.00 < \text{URA} \leq 3072.00$
12	$768.00 < \text{URA} \leq 1536.00$
11	$384.00 < \text{URA} \leq 768.00$
10	$192.00 < \text{URA} \leq 384.00$
9	$96.00 < \text{URA} \leq 192.00$
8	$48.00 < \text{URA} \leq 96.00$
7	$24.00 < \text{URA} \leq 48.00$
6	$13.65 < \text{URA} \leq 24.00$
5	$9.65 < \text{URA} \leq 13.65$
4	$6.85 < \text{URA} \leq 9.65$
3	$4.85 < \text{URA} \leq 6.85$
2	$3.40 < \text{URA} \leq 4.85$
1	$2.40 < \text{URA} \leq 3.40$
0	$0.00 < \text{URA} \leq 2.40$
-1	$1.20 < \text{URA} \leq 1.70$
-2	$0.85 < \text{URA} \leq 1.20$
-3	$0.60 < \text{URA} \leq 0.85$

-4	$0.43 < \text{URA} \leq 0.60$
-5	$0.30 < \text{URA} \leq 0.43$
-6	$0.21 < \text{URA} \leq 0.30$
-7	$0.15 < \text{URA} \leq 0.21$
-8	$0.11 < \text{URA} \leq 0.15$
-9	$0.08 < \text{URA} \leq 0.11$
-10	$0.06 < \text{URA} \leq 0.08$
-11	$0.04 < \text{URA} \leq 0.06$
-12	$0.03 < \text{URA} \leq 0.04$
-13	$0.02 < \text{URA} \leq 0.03$
-14	$0.01 < \text{URA} \leq 0.02$
-15	< 0.01
-16	No accuracy prediction is available

For each URA index (N), users may compute a nominal URA value (X) as given by:

- If the value of N is 6 or less, but more than -16, $X = 2^{(1 + N/2)}$.
- If the value of N is 6 or more, but less than 15, $X = 2^{(N - 2)}$.
- If $N = 15$ or $N = -16$ shall indicate the absence of an accuracy prediction and shall advise the user not to use that SV.
- If $4 > N \geq 14$ shall indicate very high ranging error and advise user to use the SV at their own risk.

For $N = 1, 3,$ and 5 , X should be rounded to 2.8, 5.7, and 11.3 meters, respectively.

6.2.1.9 Ephemeris Parameters

The coordinates of the NavIC satellite's antenna phase center position in ECEF reference frame shall be computed by the user utilizing the Ephemeris parameters in the following Table 22. The algorithm for computing satellite antenna phase center is provided in Appendix A.

Table 22: List of Ephemeris parameters

S.No	Parameter	Notation
	Argument of Perigee	ω
	Amplitude of the Cosine Harmonic Correction Term to the Argument of Latitude	C_{uc}
	Amplitude of the Sine Harmonic Correction Term to the Arg. of Latitude	C_{us}
	Amplitude of the Cosine Harmonic Corr. Term to the Angle of Inclination	C_{ic}
	Amplitude of the Sine Harmonic Corr. Term to the Angle of Inclination	C_{is}

	Amplitude of the Cosine Harmonic Correction Term to the Orbit Radius	C_{rc}
	Amplitude of the Sine Harmonic Correction Term to the Orbit Radius	C_{rs}
	Semi-major Axis Difference at reference time	ΔA
	Mean Motion Difference	Δn
	Eccentricity	e
	Rate of Inclination angle	IDOT
	Inclination	i_o
	Longitude of Ascending Node	Ω_o
	Mean Anomaly	M_o
	Rate of RAAN	$\dot{\Omega}$
	Change rate in semi-major axis	\dot{A}
	Rate of Mean Motion Difference	$\Delta \dot{n}$
	Time of ephemeris & clock (TOEC)	t_{oec}

6.2.1.10 Signal Delays

The signal delay values broadcast in NavIC L1-SPS signal are captured in the Table 23:

Table 23: Signal Delay Parameters

Total Group Delay	TGD
Inter Signal Correction for -L1 SPS Pilot Signal/ Inter Signal Correction for -S SPS Signal	ISC_{L1P}/ISC_S^{**}
Inter Signal Correction for -L1 SPS Data Signal	ISC_{L1D}

**As mentioned in Table 13, respective ISC's will be transmitted based on the RSF flag, (Refer Appendix C); That is, if $RSF = 1$, ISC_{L1P} will be broadcasted; if $RSF = 0$, ISC_S will be broadcasted;

The user algorithm for correcting for satellite time using signal delays is given in Appendix C.

6.2.2 Subframe 3

6.2.2.1 Message Identifier (Message ID)

The 6-bit message identifier uniquely identifies the message type in subframe 3. The list of messages are defined in section 6.1.3.

6.2.2.2 Invalid Data Flag

The Invalid Data Flag when set to '1' signifies to the users that the data in the message is Idle Pattern and not to be used.

6.2.2.3 Message Type 5 Data contents

Message type 5 contains the ionosphere grid corrections for grid points over Indian region. The ionospheric delay corrections are broadcasted as vertical delay estimates at specified Ionospheric Grid Points (IGPs), applicable to a signal on L5 for the single frequency users over the Indian land mass. This includes 90 IGPs at 350 km above the Earth surface. The 90 IGPs identified for grid based servicing is shown in Figure 23. Since the total IGPs cannot be broadcasted in a single message, these 90 IGPs are divided into 6 regions. Each message contains the corrections for 1 region, containing 15 IGPs (with grid size of 5°x5°). The grid based corrections for the single frequency users (L5) over the Indian region include:

- Region ID
- Grid Ionosphere Vertical Delay (GIVD)
- Grid Ionosphere Vertical Error Indicator (GIVEI)
- Regions Masked (10 bits)
- Issue of Data Ionosphere (IODI)

The corrections: Grid Ionosphere Vertical Delay on L5 (GIVD) & their 99.9% accuracy, called the Grid Ionosphere Vertical Error Indicator (GIVEI) are provided at each IGP. The region masked indicates the total number of regions for which the corrections are provided. For the current service area of NavIC, regions masked are 6. IODI is used to indicate a change in region masked. It ranges from 0 to 7. It is incremented by 1 with a change in regions masked and is reset to 0 after reaching maximum of 7. The description of the region id and index with respect to the IGP location is provided in Table 24 . The IGP locations must be stored permanently by the user along with the region id for each IGP within the region. For the broadcast region id, the user in-turn will derive the IGP latitude and longitude from the stored values.

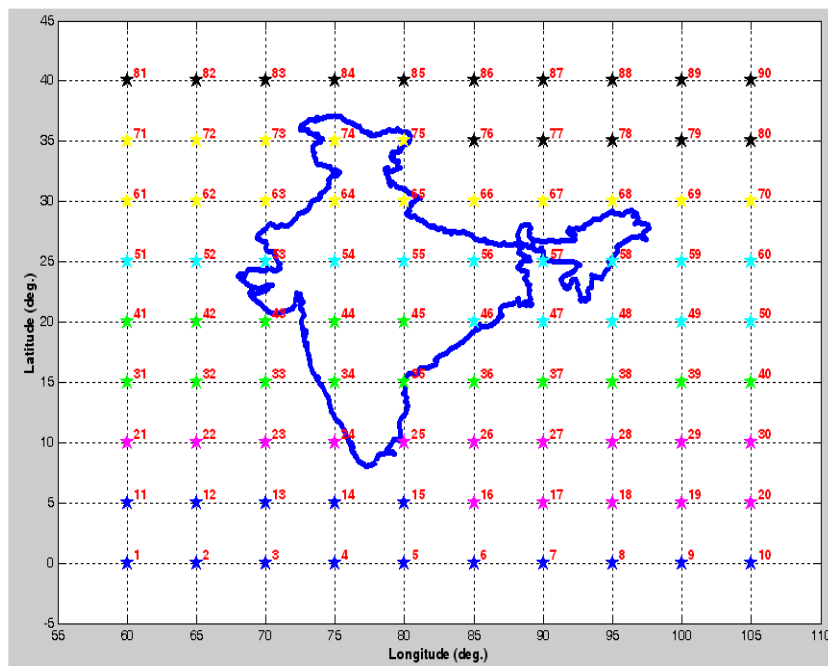

Figure 23: Identified IGPs for Grid Based Corrections over Indian Region

Table 24: Region Id and index for identified IGP locations

S.No	Lon (deg)	Lat (deg)	Region ID	Index
1	60	0	0	0
2	65	0	0	1
3	70	0	0	2
4	75	0	0	3
5	80	0	0	4
6	85	0	0	5
7	90	0	0	6
8	95	0	0	7
9	100	0	0	8
10	105	0	0	9
11	60	5	0	10
12	65	5	0	11
13	70	5	0	12
14	75	5	0	13
15	80	5	0	14
16	85	5	1	0
17	90	5	1	1
18	95	5	1	2
19	100	5	1	3
20	105	5	1	4
21	60	10	1	5
22	65	10	1	6
23	70	10	1	7
24	75	10	1	8
25	80	10	1	9
26	85	10	1	10
27	90	10	1	11
28	95	10	1	12
29	100	10	1	13
30	105	10	1	14
31	60	15	2	0
32	65	15	2	1
33	70	15	2	2
34	75	15	2	3
35	80	15	2	4
36	85	15	2	5
37	90	15	2	6
38	95	15	2	7
39	100	15	2	8
40	105	15	2	9
41	60	20	2	10
42	65	20	2	11
43	70	20	2	12
44	75	20	2	13

45	80	20	2	14
46	85	20	3	0
47	90	20	3	1
48	95	20	3	2
49	100	20	3	3
50	105	20	3	4
51	60	25	3	5
52	65	25	3	6
53	70	25	3	7
54	75	25	3	8
55	80	25	3	9
56	85	25	3	10
57	90	25	3	11
58	95	25	3	12
59	100	25	3	13
60	105	25	3	14
61	60	30	4	0
62	65	30	4	1
63	70	30	4	2
64	75	30	4	3
65	80	30	4	4
66	85	30	4	5
67	90	30	4	6
68	95	30	4	7
69	100	30	4	8
70	105	30	4	9
71	60	35	4	10
72	65	35	4	11
73	70	35	4	12
74	75	35	4	13
75	80	35	4	14
76	85	35	5	0
77	90	35	5	1
78	95	35	5	2
79	100	35	5	3
80	105	35	5	4
81	60	40	5	5
82	65	40	5	6
83	70	40	5	7
84	75	40	5	8
85	80	40	5	9
86	85	40	5	10
87	90	40	5	11
88	95	40	5	12
89	100	40	5	13
90	105	40	5	14

The GIVEI is a 4-bit GIVE indicator and it ranges from 0 to 15. The corresponding GIVE value for each of the indicator is provided in Table 25.

Table 25: Evaluation of GIVEI

GIVEI_i	GIVE_i Meters	σ^2, GIVE Meters²
0	0.3	0.0084
1	0.6	0.0333
2	0.9	0.0749
3	1.20	0.1331
4	1.5	0.2079
5	1.8	0.2994
6	2.1	0.4075
7	2.4	0.5322
8	2.7	0.6735
9	3.0	0.8315
10	3.6	1.1974
11	4.5	1.8709
12	6.0	3.3260
13	15.0	20.7870
14	45.0	187.0826
15	Not Monitored	Not Monitored

A The 9-bit IGP vertical delays have a 0.125-meter resolution, for 0 to 63.750-meter valid range. A vertical delay of 63.875 meters (111111111) will indicate “Don’t Use” which means there are no IGP vertical delays greater than 63.750 meters. If that range exceeds, a “Don’t Use” indication will be given and the user will not use the IGP for interpolation technique used in the computation of ionospheric error along his line-of-sight. The user algorithm for computing the delay and associated confidence for the user Line of Sight (LOS) from GIVD and GIVE, is described in detail in Appendix D.

6.2.2.4 Message Type 6 Data Contents

Message Type 6 contains satellite almanac data. The almanac is a subset of the clock and ephemeris data, with reduced precision. The user algorithm is given in 0. The almanac content for one SV is given in Table 26 which holds good for other NavIC satellites as well.

Table 26: Almanac Parameters Definitions

Parameters	Definitions
WN_a	Week number for almanac
E	Eccentricity
t_{oa}	Time of almanac
i_0	Inclination
$\dot{\Omega}$	Rate of RAAN
\sqrt{A}	SQRT A
Ω_0	Longitude of ascending node(LAN)
ω	Argument of perigee

M_0	Mean anomaly
a_{f0}	Clock bias A0
a_{f1}	Clock drift A1

6.2.2.5 Message Type 8 Data Contents

(Reserved for new NavIC Iono message)

6.2.2.6 Message Type 10 Data Contents

(a) Earth Orientation Parameters

The Earth Orientation Parameters message provides the users with parameters to construct the ECEF and ECI coordinate transformation. The parameters are

- a) UT1- UTC Difference at reference time
- b) X-Axis Polar motion value at reference time and
- c) Y-Axis Polar motion value at reference time.

The time difference between the UT1 and UTC time scale is designated as $\Delta UT1$ and the parameter is represented with two parameters. $\Delta UT1$ and $(\Delta UT1)$. The first parameter indicates the time difference between UT1 and UTC at the reference time t_{EOP} and the second parameter represents the rate of change of the time difference.

The X Axis Polar motion value at reference time is represented with two parameters, PM_X and (PM_X) . The first parameter indicates the predicted angular displacement of instantaneous Celestial Intermediate Pole with respect to semi-minor axis of the reference ellipsoid along Greenwich meridian. The second parameter represents the rate of change of the X Axis polar motion.

The Y Axis Polar motion value at reference time is represented with two parameters, PM_Y and (PM_Y) . The first parameter indicates the predicted angular displacement of instantaneous Celestial Intermediate Pole with respect to semi-minor axis of the reference ellipsoid along a line directed 90°W of Greenwich meridian. The second parameter represents the rate of change of the Y Axis polar motion.

For information regarding the usage of the Earth Orientation Parameters, refer to Appendix G.

(b) Klobuchar like Ionosphere Coefficients

Ionospheric error correction for single frequency users of the NavIC will be provided through a set of eight Klobuchar like coefficients. The calculated value of ionosphere correction parameter (T_{iono}) in the model is referred to the L5 frequency. If the user is operating on L1 frequency, the correction term must be multiplied by γ_{51} which is defined in Appendix H.

The correction coefficients are:

- 4 Alpha coefficients (α_n ; $n=0,1,2,3$)

These are the coefficients of the cubic polynomial representing the Amplitude of the positive cosine curve in the cosine model approximation of ionospheric delay.

- 4 Beta coefficients (β_n ; $n=0,1,2,3$)

These are the coefficients of the cubic polynomial representing the Period of the positive cosine curve in the cosine model approximation of ionospheric delay.

- Maximum and minimum Longitude limit

It defines valid longitude coverage area for the broadcast coefficients.

- Maximum and minimum Latitude limit

It defines valid latitude coverage area for the broadcast coefficients.

- Issue of Data Ionosphere with Klobuchar

Indicates change in coefficients (on update) and the user is requested to use updated coefficients

User is requested to use the coefficients if user's geodetic location comes within the valid longitude and latitude coverage limit of the coefficients. The ionospheric error along the user's line-of-sight is computed using the algorithm described in Appendix H.

6.2.2.7 Message type 17 Data Contents

Message Type 17 contains the parameters required to relate the NavIC time to UTC, UTC (NPLI) and other GNSS viz. GPS, GALILEO and GLONASS. NavIC time offset with respect to UTC and UTC (NPLI) are provided by the following parameters:

1. Bias coefficients of NavIC time scale relative to UTC and UTC (NPLI) time scales as A_{0utc} and A_{0npli} respectively.
2. Drift coefficients of NavIC time scale relative to UTC and UTC (NPLI) time scales as A_{1utc} and A_{1npli} respectively.
3. Drift rate correction coefficients of NavIC time scale relative to UTC and UTC (NPLI) time scales as A_{2utc} and A_{2npli} respectively.
4. Current or past leap second count (Δt_{LS})
5. Coefficient's reference time of week (t_{ug})
6. Coefficient's reference week number (WN_{ug})
7. Leap second reference week number (WN_{LSF})
8. Leap second reference day number (DN)
9. Current or future leap second count (Δt_{LSF})

These parameters relate the NavIC time to UTC and UTC (NPLI) provide information to the user regarding the scheduled future or recent past (relative to the current broadcast time offset parameters) value of delta time due to leap seconds (Δt_{LSF}) together with the week number (WN_{LSF}) and the day number (DN) at the end of which the leap second becomes effective. Day one is the first day relative to the end/start of week and WN_{LSF} is the leap second reference week number to which the DN is referenced.

NavIC time can be related to GNSS using the following parameters:

1. Bias coefficient of NavIC time scale relative to GNSS time (A_{0gnss})
2. Drift coefficient of NavIC time scale relative to GNSS time (A_{1gnss})
3. Coefficient's reference time of week (t_{ug}).
4. Coefficient's reference week number (WN_{ug}).
5. GNSS Identifier (GNSS ID)

Valid/Invalid flag for a given timescale or GNSS indicates whether the corresponding coefficients are usable or not. Flag value '1' represents the parameters are usable, '0' indicates not usable.

GNSS ID identifies the GNSS for which the time offsets with respect to NavIC are provided. The mapping between GNSS ID and the corresponding GNSS is provided in Table 27.

Table 27: GNSS ID to GNSS Mapping

GNSS ID	GNSS
0	GPS
1	GALILEO
2	GLONASS
3-7	Reserved

The user algorithm to derive UTC time (t_{UTC}), GNSS time(t_{GNSS}) and UTC (NPLI) time ($t_{UTC(NPLI)}$) are provided in Appendix F.

Update to the contents of message type 17 is indicated by change in Issue of Data Time (IODT). The IODT is sequence number ranging from 0 to 7 in a cyclic manner.

6.3 BROADCAST INTERVAL

Broadcast of subframes and messages is sequenced to provide optimum user performance. Subframes 1, 2 and 3 are broadcast once every 18 seconds. Messages shall be broadcast as part of subframe 3, not exceeding the maximum broadcast interval. Message type 0 is transmitted when there are no messages that have reached their maximum broadcast interval and no messages waiting for broadcast. Flexibility exists for the broadcast of messages as distributed across NavIC satellites for better service. In addition, messages with multiple segments can be broadcasted such that different NavIC satellites broadcast different segments for the same message. Message broadcast sequence are not necessarily synchronized across different NavIC satellites.

Table 28 provides the maximum broadcast interval for different sub-frames / message types.

Table 28: Maximum Broadcast Interval

Subframe/Message Data	Subframe id / Message id	Maximum Broadcast Interval @ 100sps
TOI	SF1	18 sec
Ephemeris, Clock and Group Delay	SF2	18 sec
Iono Grid Parameters	SF3/MT5	5 min
Almanac	SF3/MT6	60 min
Reserved for new IONO message	SF3/MT8	--
EOP and Klobuchar like ionosphere coefficients	SF3/MT10	10 min
NavIC time offset with respect to UTC/UTC(NPLI) & other GNSS	SF3/MT17	20 min

APPENDICES

Appendix A. Algorithm for Ephemeris Computation

The user shall compute the ECEF coordinates of position for the phase center of the NavIC Satellite antennas utilizing the equations shown below. Subframes 2 ephemeris parameters are Keplerian in appearance;

$$\mu = 3.986005 \times 10^{14} \text{ meters}^3/\text{sec}^2 \quad \text{-WGS 84 value of the earth's gravitational constant for NavIC user}$$

$$\dot{\Omega}_e = 7.2921151467 \times 10^{-5} \text{ rad/sec} \quad \text{-WGS 84 value of the earth's rotation rate}$$

$$A_{\text{ref}} = 42164200 \text{ meters} \quad \text{-Reference semi-major axis for NavIC GSO/IGSO satellites}$$

Time from reference epoch:

$$t_k = t - t_{\text{occ}}$$

- t is NavIC system time at time of transmission, i.e., NavIC time corrected for transit time (range/speed of light)
- t_{occ} Time of ephemeris/clock in seconds
- If $t_k \geq 302400$ subtract 604800 from t_k
- If $t_k \leq -302400$ add 604800 to t_k

$$A_0 = A_{\text{ref}} + \Delta A \quad \text{-Semi-major axis at Reference time}$$

$$a = A_0 + \dot{A} t_k \quad \text{-Semi-Major Axis}$$

$$\Delta n = \Delta n_0 + \frac{1}{2} \dot{\Delta n} t_k \quad \text{-Computed Mean Motion Difference}$$

$$n_0 = \sqrt{(\mu/a)/a} \quad \text{-Computed mean motion (rad/sec)}$$

Corrected mean motion:

$$n = n_0 + \Delta n$$

Mean anomaly:

$$M_k = M_0 + n t_k$$

Kepler's Equation for Eccentric Anomaly (may be solved by iteration):

$$M_k = E_k - e \sin E_k$$

True Anomaly:

$$v_k = \tan^{-1} \left(\frac{\sin v_k}{\cos v_k} \right)$$

where

$$\sin v_k = \sqrt{1 - e^2} \sin E_k / (1 - e \cos E_k)$$

$$\cos v_k = (\cos E_k - e) / (1 - e \cos E_k)$$

Argument of Latitude:

$$\Phi_k = v_k + \omega$$

Second Harmonic Perturbations:

$$\delta u_k = c_{us} \sin 2 \Phi_k + c_{uc} \cos 2 \Phi_k$$

$$\delta r_k = c_{rs} \sin 2 \Phi_k + c_{rc} \cos 2 \Phi_k$$

$$\delta i_k = c_{is} \sin 2 \Phi_k + c_{ic} \cos 2 \Phi_k$$

Corrected Argument of Latitude:

$$u_k = \Phi_k + \delta u_k$$

Corrected Radius:

$$r_k = a(1 - e \cos E_k) + \delta r_k$$

Corrected Inclination:

$$i_k = i_0 + \delta i_k + (IDOT)t_k$$

Position in orbital Plane:

$$x'_k = r_k \cos u_k$$

$$y'_k = r_k \sin u_k$$

Corrected longitude of ascending node:

$$\Omega_k = \Omega_0 + (\dot{\Omega} - \dot{\Omega}_e)t_k - \dot{\Omega}_e t_{oeec}$$

Earth-fixed coordinates:

$$x_k = x'_k \cos \Omega_k - y'_k \cos i_k \sin \Omega_k$$

$$y_k = x'_k \sin \Omega_k + y'_k \cos i_k \cos \Omega_k$$

$$z_k = y'_k \sin i_k$$

Appendix B. User Algorithms for SV Clock Correction Data

The clock coefficients transmitted as part of subframe 2 are used for NavIC time and clock correction. The coefficients transmitted in subframe 2 describe the offset apparent to the user for the interval of time in which the parameters are transmitted. This estimated correction accounts for the deterministic satellite clock error characteristics of bias, drift and aging. The user equipment shall determine the requisite relativistic correction. Accordingly, the offset given below includes a term to perform this function.

The user shall correct the time received from the satellite with the equation (in seconds):

$$t = t_{sv} - \Delta t_{sv} \text{ where,}$$

t = NavIC system time (seconds) at message transmission time

t_{sv} = effective satellite PRN code phase time at message transmission time (seconds),

Δt_{sv} = satellite PRN code phase time offset (seconds).

The Satellite PRN code phase offset is given by:

$$\Delta t_{sv} = a_{f0} + a_{f1}(t - t_{oec}) + a_{f2}(t - t_{oec})^2 + \Delta t_r \text{ where,}$$

a_{f0} , a_{f1} and a_{f2} are the polynomial coefficients, t_{oec} is the ephemeris and clock data reference time in seconds, and Δt_r is the relativistic correction term (seconds) which is given by:

$$\Delta t_r = F e \sqrt{A_0} \sin(E_k)$$

The orbit parameters (e , A_0 , E_k) used here are defined in Appendix A,

While F is a constant given by

$$F = \frac{-2\sqrt{\mu}}{c^2} = -4.442807633 \times 10^{-10} \text{ sec}/\sqrt{\text{meter}}$$

Appendix C. Inter-signal Correction for Single and Dual frequency users

C.1 Algorithm for Reference Signal Flag (RSF) value 1

Single Frequency (L1D, L1P) user

The correction term TGD, ISC_{L1D} and ISC_{L1P} are provided to account for the effect of SV inter signal biases between S-L5, S-L1D and S-L1P respectively. For maximum accuracy, the single frequency L1D and L1P users apply the correction term with the equations given below:

$$(\Delta t_{sv})_{L1D} = \Delta t_{sv} - TGD + ISC_{L1D}$$

$$(\Delta t_{sv})_{L1P} = \Delta t_{sv} - TGD + ISC_{L1P}$$

where, TGD is the total group delay, ISC_{L1D} , ISC_{L1P} are the mean SV group delay differential between S and L1 data and between S and L1 pilot respectively.,

$$ISC_{L1D} = t_S - t_{L1D}$$

$$ISC_{L1P} = t_S - t_{L1P}$$

where t_S , t_{L1P} and t_{L1D} are the NavIC time of the S, L1P and L1D signals transmitted from SV antenna phase center.

Dual Frequency (S-L1) user

The S-L1D dual frequency user shall correct for the group delay and ionospheric effects by applying the following equation:

$$\rho = \frac{\rho_{L1D} - \gamma_1 \rho_S + c * ISC_{L1D}}{1 - \gamma_1} - c * TGD$$

The S-L1P dual frequency user shall correct for the group delay and ionospheric effects by applying the following equation:

$$\rho = \frac{\rho_{L1P} - \gamma_1 \rho_S + c * ISC_{L1P}}{1 - \gamma_1} - c * TGD$$

where,

c = speed of light.

TGD = Total Group Delay between S-L5.

ISC_{L1D}, ISC_{L1P} = Inter-Signal Corrections between S and L1D, S and L1P respectively.

ρ = pseudorange corrected for 1st order ionospheric effects.

$\rho_{L1D}, \rho_{L1P}, \rho_S$ = pseudorange measured on the channels indicated by the subscript.

$$\gamma_1 = \frac{f_S^2}{f_{L1}^2}$$

Dual Frequency (L5-L1) user

The L5-L1D dual frequency user shall correct for the group delay and ionospheric effects by applying the following equation:

$$\rho = \frac{\rho_{L5} - \gamma_{15}\rho_{L1D} - \gamma_{15} * c * ISC_{L1D} - (\gamma - \gamma_{15}) * c * TGD}{1 - \gamma_{15}}$$

The L5-L1P dual frequency user shall correct for the group delay and ionospheric effects by applying the equation:

$$\rho = \frac{\rho_{L5} - \gamma_{15}\rho_{L1P} - \gamma_{15} * c * ISC_{L1P} - (\gamma - \gamma_{15}) * c * TGD}{1 - \gamma_{15}}$$

where,

c = speed of light.

TGD = Total group delay between S-L5 .

ISC_{L1D}, ISC_{L1P} = Inter-signal corrections between S and L1D, S and L1P respectively.

ρ = pseudo range corrected for 1storder ionospheric effects.

ρ_{L1D} , ρ_{L1P} , ρ_{L5} = pseudorange measured on the channels indicated by the subscript.

$$\gamma_{15} = \frac{f_{L1}^2}{f_{L5}^2}$$

$$\gamma = \frac{f_s^2}{f_{L5}^2}$$

C.2 Algorithm for Reference Signal Flag (RSF) value 0

Single Frequency (L1P, L1D) user

The correction term TGD, ISC_{L1D} and ISC_S are provided to account for the effect of SV inter signal biases between L1P-L5, L1P-L1D and L1P-S respectively. For maximum accuracy, the single frequency L1D and L1P users apply the correction term with the equations given below:

$$(\Delta t_{sv})_{L1D} = \Delta t_{sv} - TGD + ISC_{L1D}$$

$$(\Delta t_{sv})_{L1P} = \Delta t_{sv} - TGD$$

where, TGD is the total group delay, ISC_{L1D}, ISC_S are the mean SV group delay differential between L1 Pilot and L1 data, L1 Pilot and S respectively.,

$$ISC_{L1D} = t_{L1P} - t_{L1D}$$

$$ISC_S = t_{L1P} - t_S$$

where t_S , t_{L1P} and t_{L1D} are the NavIC time of the S, L1P and L1D signals transmitted from SV antenna phase center.

Dual Frequency (S-L1) user

The S-L1D dual frequency user shall correct for the group delay and ionospheric effects by applying the following equation:

$$\rho = \frac{\rho_{SD} - \gamma_{L1S}\rho_{L1D} + c * ISC_S - \gamma_{L1S}c * ISC_{L1D}}{1 - \gamma_{L1S}} - c * T_{GD}$$

The S-L1P dual frequency user shall correct for the group delay and ionospheric effects by applying the following equation:

$$\rho = \frac{\rho_{SD} - \gamma_{L1S}\rho_{L1P} + c * ISC_S}{1 - \gamma_{L1S}} - c * T_{GD}$$

where,

c = speed of light.

TGD = Total group delay between L1P-L5.

ISC_{L1D}, ISC_S = Inter-signal corrections between L1P-L1D, L1P-S respectively.

ρ = pseudorange corrected for 1st order ionospheric effects.

$\rho_{L1D}, \rho_{L1P}, \rho_{SD}$ = pseudorange measured on the channels indicated by the subscript.

$$\gamma_{L1S} = \frac{f_{L1}^2}{f_S^2}$$

Dual Frequency (L5-L1) user

The L5-L1D dual frequency user shall correct for the group delay and ionospheric effects by applying the following equation:

$$\rho = \frac{\rho_{L5} - \gamma_{15}\rho_{L1D} - \gamma_{15}c * ISC_{L1D}}{1 - \gamma_{15}}$$

The L5-L1P dual frequency user shall correct for the group delay and ionospheric effects by applying the following equation:

$$\rho = \frac{\rho_{L5} - \gamma_{15}\rho_{L1P}}{1 - \gamma_{15}}$$

where,

c = speed of light.

TGD = Total group delay between L1P-L5.

ISC_{L1D} = Inter-signal corrections between L1P-L1D.

ρ = pseudorange corrected for 1st order ionospheric effects.

$\rho_{L1D}, \rho_{L1P}, \rho_{L5D}$ = pseudorange measured on the channels indicated by the subscript.

$$\gamma_{15} = \frac{f_{L1}^2}{f_{L5}^2}$$

Appendix D. User Algorithm for Ionosphere Delay Corrections for Single Frequency User using Ionosphere Grid Corrections

The corrections are provided at $5^\circ \times 5^\circ$ grids at 350 km altitude. The user first computes the point where its LOS cuts the 350 km altitude. This point is termed as the ‘‘Ionosphere Pierce Point’’ (IPP) of the user. Further, using an interpolation scheme, the users takes the information (GIVD, GIVE) from the surrounding grid points to its IPP to compute the vertical delay and the confidence at the IPP. The vertical delay is then converted to slant (along the LOS) using a mapping function.

D.1. Pierce Point Location Determination:

Considering the satellite and user locations, the user must first determine the location of the IPP of the signal path from the satellite. The following equations provide the latitude and longitude of that pierce point. First, the latitude of IPP is computed as:

$$\Phi_{pp} = \sin^{-1}(\sin(\Phi_u) \cdot \cos(\Psi_{pp}) + \cos(\Phi_u) \cdot \sin(\Psi_{pp}) \cdot \cos(A)) \quad \text{radians}$$

where, as illustrated in Figure 24, Ψ_{pp} is the earth's central angle between the user position and the earth projection of the pierce point and is computed as:

$$\Psi_{pp} = \frac{\pi}{2} - E - \sin^{-1}\left(\frac{\left(\frac{R_e}{R_e+h}\right)}{\cos(E)}\right) \quad \text{radians}$$

A and E are the azimuth and elevation angles of the satellite from the user's location (ϕ_u, λ_u), measured with respect to the local-tangent-plane, R_e is the approximate radius of the earth's ellipsoid (taken to be 6378.1363 km), and h is the height of the maximum electron density (assumed to be equal to 350 km). The longitude of the pierce point is then:

$$\lambda_{pp} = \lambda_u + \sin^{-1}\left(\sin(\Psi_{pp}) \cdot \frac{\sin(A)}{\cos(\Phi_{pp})}\right) \quad \text{radians}$$

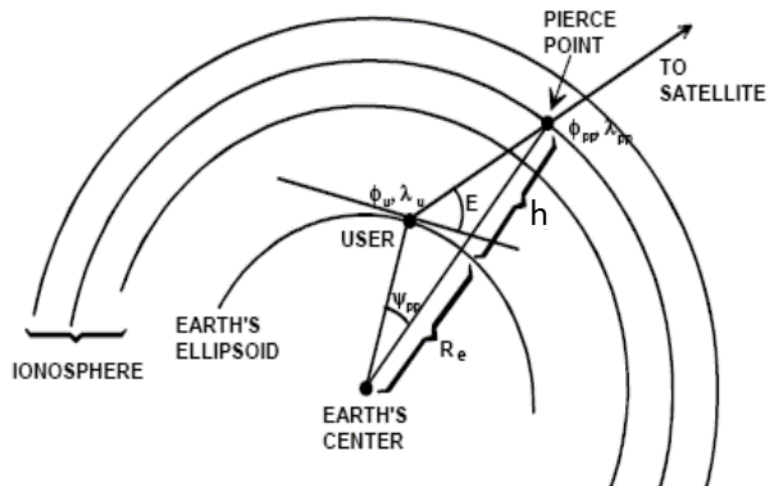

Figure 24: Ionospheric Pierce Point Geometry

D.2. Selection of Ionospheric Grid Points (IGPs):

After determining the location of the user ionospheric pierce point, the user must select the IGPs to be used to interpolate the ionospheric corrections. This selection is done without regard to whether or not the selected IGPs are monitored, not monitored, or with don't use status.

The selection of IGPs is accomplished as follows.

- Select the four IGPs that define a $5^\circ \times 5^\circ$ cell around the IPP are selected if all the IGPs are Monitored (i.e., the GIVEI ≤ 14). Else,
- Select the three IGPs that define a $5^\circ \times 5^\circ$ triangle that circumscribes the IPP are selected (Figure 25)
- If one of the IGPs out of the three selected have GIVEI > 14 , then no ionospheric corrections are available for that LOS

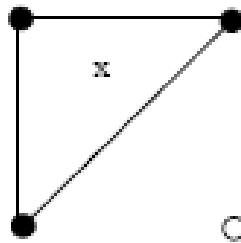

Figure 25: Example of 5x5 triangle

D.3. Ionospheric Pierce Point Vertical Delay & Model Variance Interpolation:

Given three or four nodes of a cell of the IGP grid described above that surround the user's ionospheric pierce point to a satellite, the user can interpolate from those nodes to his pierce point using the algorithm described below.

The IGPs as selected must be used for interpolation, with one exception. If four IGPs were selected, and one of the four is identified as "not monitored", then the three-point interpolation should be used if the user's pierce point is within the triangular region covered by the three corrections that are provided. If one of the four is identified as "don't use", the entire square must not be used.

D.4. Four Point Interpolation:

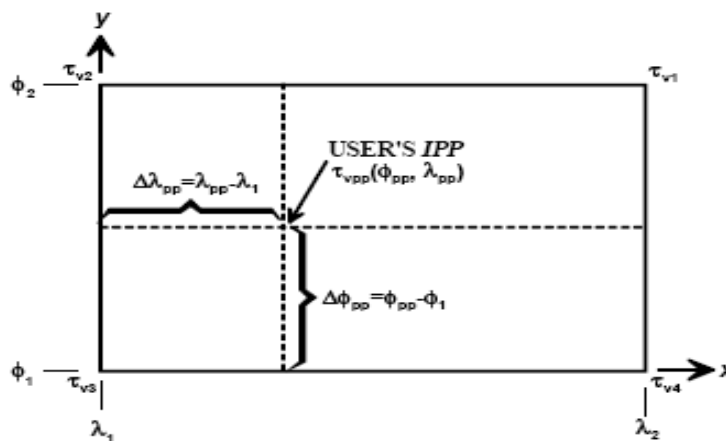

Figure 26: Four Point Interpolation Algorithm

D.4.1. Definition:

For four-point interpolation, the mathematical formulation for interpolated vertical ionospheric pierce point delay $\tau_{vpp}(\phi_{pp}, \lambda_{pp})$ as a function of ionospheric pierce point latitude ϕ_{pp} and longitude λ_{pp} is:

$$\tau_{vpp}(\Phi_{pp}, \lambda_{pp}) = \sum W_i(x_{pp}, y_{pp})\tau_{vi}, \quad i = 1 \text{ to } 4$$

where, the general equation for the weighting function is:

$$f(x, y) = xy$$

τ_{vi} are the broadcast pierce point vertical delay values at three or four corners of the IGP grid, as shown in Figure 26. τ_{vpp} is the output value at desired pierce point pp , whose geographical coordinates are $(\phi_{pp}, \lambda_{pp})$

$$W_1(x, y) = f(x, y)$$

$$W_2(x, y) = f(1 - x, y)$$

$$W_3(x, y) = f(1 - x, 1 - y)$$

$$W_4(x, y) = f(x, 1 - y)$$

$$\Delta\lambda_{pp} = \lambda_{pp} - \lambda_1$$

$$\Delta\Phi_{pp} = \Phi_{pp} - \Phi_1$$

where,

$$x_{pp} = \frac{\Delta\lambda_{pp}}{(\lambda_2 - \lambda_1)} ; y_{pp} = \frac{\Delta\Phi_{pp}}{(\Phi_2 - \Phi_1)}$$

D.5. Three Point Interpolation:

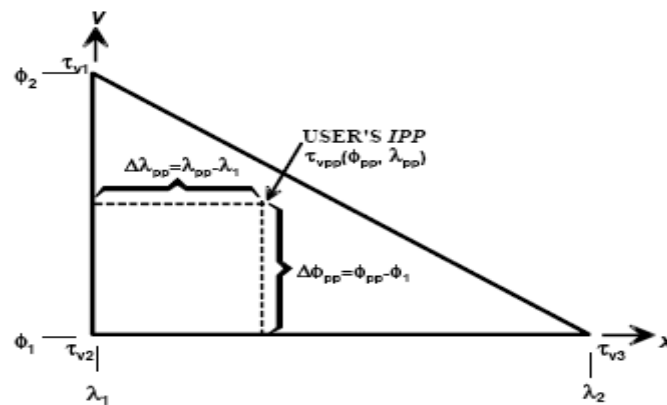

Figure 27: Three Point Interpolation Algorithm

D.5.1. Definition:

The algorithm for three point interpolation is similar to the 4 point interpolation, except for the weighting functions as given below:

$$\tau_{vpp}(\Phi_{pp}, \lambda_{pp}) = \sum W_i(x_{pp}, y_{pp})\tau_{vi}, \quad i = 1 \text{ to } 3$$

where,

$$W_1(x, y) = f(1, y)$$

$$W_2(x, y) = f(1, 1 - x - y)$$

$$W_3(x, y) = f(x, 1)$$

IGPs are numbered as shown in Figure 27, so that grid point #2 is always the vertex opposite the hypotenuse and the distance-ratios (x, y) are always determined relative to the distance to grid point #2. It should be noted that there are additional three orientations of the triangle shown in Figure 27.

The UIVE will be interpolated by the users from the GIVEs defined at the IGPs to the IPP (using four point or three point interpolations) as follows:

$$UIVE = \sum_{n=1}^4 W_n(x_{pp}, y_{pp}) \cdot GIVE_n$$

or

$$UIVE = \sum_{n=1}^3 W_n(x_{pp}, y_{pp}) \cdot GIVE_n$$

D.6. Computing Slant Ionospheric Delay and Ionospheric Model Variance:

Once the user establishes the vertical delay at the pierce point, the user can then multiply that vertical delay by the obliquity factor F_{pp} to obtain the ionospheric correction (IC) to be added to the pseudorange measurement:

$$IC = -\tau_{spp}(\Phi_{pp}, \lambda_{pp}) = -F_{pp} \cdot \tau_{vpp}(\Phi_{pp}, \lambda_{pp})$$

where τ_{vpp} is the interpolated vertical delay at the user-to-satellite ionospheric pierce point derived as described above, where,

$$F_{pp} = \left(1 - \left(\frac{R_e \cdot \cos(E)}{R_e + h} \right)^2 \right)^{-1/2}$$

The σ^2_{UIRE} is computed as:

$$\sigma^2_{UIRE} = F_{pp}^2 \cdot \sigma^2_{UIVE}$$

where,

σ^2_{UIVE} is the variance of the UIVE.

The ionospheric correction (IC) is computed for L5 frequency. If the user is operating on the L1 frequency, the correction term must be multiplied by scale factor (γ_{51}) defined as

$$\gamma_{51} = \frac{f_{L5}^2}{f_{L1}^2}$$

Appendix E. User Algorithm for Satellite Position determination using Almanac

The almanac is a subset of the clock and ephemeris data, with reduced precision. The almanac time parameters shall consist of an 14-bit constant term (a_{f0}) and an 11-bit first order term (a_{f1}). The applicable first order polynomial, which shall provide time to within few microseconds of NavIC time (t) during the interval of applicability, is given by

$$t = t_{sv} - \Delta t_{sv} \text{ where,}$$

$$t = \text{NavIC system time (seconds),}$$

$$t_{sv} = \text{effective SV PRN code phase time at message transmission time (seconds),}$$

$$\Delta t_{sv} = \text{SV PRN code phase time offset (seconds)}$$

The SV PRN code phase offset is given by

$$\Delta t_{sv} = a_{f0} + a_{f1} t_k$$

$$t_k = t - t_{oa} \text{ Time from Almanac reference epoch}$$

- t is NavIC system time at time of transmission, i.e., NavIC time corrected for transit time (range/speed of light)
- t_{oa} Time of Almanac in second

and the polynomial coefficients a_{f0} and a_{f1} are given in the almanac. Since the periodic relativistic effect is less than 25 meters, it need not be included in the time scale used for almanac evaluation.

$$\mu = 3.986005 \times 10^{14} \text{ meters}^3/\text{sec}^2 \quad \text{-WGS 84 value of the earth's gravitational constant for NavIC user}$$

$$\dot{\Omega}_e = 7.2921151467 \times 10^{-5} \text{ rad/sec} \quad \text{-WGS 84 value of the earth's rotation rate}$$

$$a = (\sqrt{A})^2 \quad \text{-Semi-major axis in meters}$$

$$n_0 = \sqrt{(\mu/a)/a} \quad \text{-Computed mean motion (rad/sec)}$$

Time from Almanac reference epoch:

$$t_k = t - t_{oa}$$

- t is NavIC system time at time of transmission, i.e., NavIC time corrected for transit time (range/speed of light)
- t_{oa} Time of Almanac in second

Corrected mean motion:

$$n = n_0$$

Mean anomaly:

$$M_k = M_0 + n t_k$$

Kepler's Equation for Eccentric Anomaly (may be solved by iteration) (radians):

$$M_k = E_k - e \sin E_k$$

True Anomaly:

$$v_k = \tan^{-1} \left(\frac{\sin v_k}{\cos v_k} \right)$$

where

$$\sin v_k = \sqrt{1 - e^2} \sin E_k / (1 - e \cos E_k)$$

$$\cos v_k = (\cos E_k - e) / (1 - e \cos E_k)$$

Eccentric Anomaly:

$$E_k = \cos^{-1} \left(\frac{e + \cos v_k}{1 + e \cos v_k} \right)$$

Argument of Latitude:

$$\Phi_k = v_k + \omega$$

$$u_k = \Phi_k$$

Radius:

$$r_k = a(1 - e \cos E_k)$$

Inclination:

$$i_k = i_0$$

Position in orbital Plane:

$$x'_k = r_k \cos u_k$$

$$y'_k = r_k \sin u_k$$

Corrected longitude of ascending node:

$$\Omega_k = \Omega_0 + (\dot{\Omega} - \dot{\Omega}_e)t_k - \dot{\Omega}_e t_{oa}$$

Earth-fixed coordinates:

$$x_k = x'_k \cos \Omega_k - y'_k \cos i_k \sin \Omega_k$$

$$y_k = x'_k \sin \Omega_k + y'_k \cos i_k \cos \Omega_k$$

$$z_k = y'_k \sin i_k$$

Appendix F. User Algorithm for computation of NavIC time offset w.r.t UTC, UTC(NPLI) and other GNSS

F.1. User Algorithm For UTC correlation with NavIC time

Based on the time of applicability of the parameters in message Type 17, UTC time can be derived as follows:

- a. Whenever the time of applicability indicated by the WN_{LSF} and the DN values is not in the past (relative to the user's present time), and the user's present time does not fall in the time span which starts at six hours prior to the time of applicability and end sat six hours after the time of applicability, the UTC time (t_{UTC}) can be derived as:

$$t_{UTC} = (t_E - \Delta t_{UTC}) [\text{modulo } 86400 \text{ seconds}] \text{ seconds}$$

and Δt_{UTC} is derived as

$$\Delta t_{UTC} = \Delta t_{LS} + A_{0utc} + A_{1utc}(t_E - t_{ug} + 604800(WN - WN_{ug})) + A_{2utc}(t_E - t_{ug} + 604800(WN - WN_{ug}))^2 \text{ seconds}$$

where

t_E = NavIC time in seconds as estimated by the user after correcting t_{SV} relative to end/start of week;

Δt_{LS} = delta time due to leap seconds;

A_{0utc}, A_{1utc} and A_{2utc} = constant, first and second order terms of polynomial;

t_{ug} = reference time for data ;

WN = current week number (derived from sub-frame 1),

WN_{ug} = Reference week number for data.

- b. Whenever the user's current time falls within the time span of six hours prior to the time of applicability to six hours after the time of applicability, proper accommodation of the leap second event with a possible week number transition, the UTC time (t_{UTC}) can be derived as:

$$t_{UTC} = W [\text{modulo } (86400 + \Delta t_{LSF} - \Delta t_{LS})] \text{ seconds}$$

Where,

$$W = (t_E - \Delta t_{UTC} - 43200) [\text{modulo } 86400] + 43200 \text{ seconds}$$

and the definition of Δt_{UTC} applies as above throughout the transition period. Whenever a leap second event is encountered, the user equipment must consistently implement carries or borrows into any year/week/day counts.

- c. Whenever the affectivity time of the leap second event, as indicated by the WN_{LSF} and DN values, is in the "past" (relative to the user's current time), and the user's current time does not fall in the time span as given in (b), the relationship previously given for t_{UTC} in (a) above is valid except that the value of Δt_{LSF} is substituted for Δt_{LS} .

The user must account for the truncation of WN , WN_{ug} and WN_{LSF} due to rollover of full week number.

F.2. User Algorithm For GNSS time correlation with NavIC time

The GNSS time (t_{GNSS}) is derived using the following relationship:

$$t_{GNSS} = t_E - (A_{0gnss} + A_{1gnss}(t_E - t_{ug} + 604800 (WN - WN_{ug}))) \text{ seconds}$$

where,

t_E = NavIC time in seconds as estimated by the user after correcting t_{sv} as given in Appendix B.

WN = current week number (derived from sub-frame 1)

F.3. User Algorithm For UTC(NPLI) correlation with NavIC time

The user algorithm to be applied for deriving UTC(NPLI) time ($t_{UTC(NPLI)}$) is same as in F.1 except that t_{UTC} , A_{0utc} , A_{1utc} , A_{2utc} to be replaced with $t_{UTC(NPLI)}$, A_{0npli} , A_{1npli} and A_{2npli} respectively.

Appendix G. User Algorithm for application of Earth Orientation Parameters (EOP)

The EOP fields in NavIC message type 10 contain the EOP needed to construct the ECEF-to-ECI coordinate transformation. The user computes the ECEF position of the Space Vehicle antenna phase center using the equations given in Appendix A. The full coordinate transformation for translating to the corresponding ECI Space Vehicle antenna phase center position may be accomplished in accordance with the procedures described in Chapter 5 of International Earth Reference System (IERS) Technical Note 36 and the equations (G-1) and (G-2).

The IERS Technical Note 36 describes multiple methods to obtain the transformation matrix. The choice of method is left to the users discretion.

Note that the message type 10 EOP parameters already account for the tidal variations in the earth's rotation. The description of the effects is provided in Chapter 8 of IERS Technical Note 36. The tidal variations include the a) effect of tidal deformation (zonal tides) on earth's rotation and b) Diurnal, Semi-diurnal variations due to ocean tides. These effects should not be further applied by the user.

An ECI position $Reci$ is related to an ECEF position $Recef$, by a series of rotation matrices as follows:

$$Recef = [A][B][C][D] Reci$$

where the rotation matrices A,B,C and D, represent the effects of Polar Motion, Earth Rotation, Nutation and Precession, respectively. The message type 10 specifies the EOP parameters used in the construction of the Polar Motion A, and Earth Rotation B, matrices.

The user shall compute the Inertial-to-Geodetic rotation matrix in accordance to IERS Technical Note 36 and the equations for UT1, x_p and y_p are mentioned in (G-1) and (G-2).

Compute Universal Time at time t^*

$$UT1 = UTC + \Delta UT1^\dagger + \Delta \dot{UT1}^\dagger (t - t_{EOP})$$

$$UT1 = UTC + \Delta UT1 + \Delta \dot{UT1} (t - t_{EOP}) \quad (G-1)$$

Compute Polar Motion at time t

$$x_p = PM_X + \dot{PM}_X (t - t_{EOP})$$

$$y_p = PM_Y + \dot{PM}_Y (t - t_{EOP}) \quad y_p = PM_Y + \dot{PM}_Y (t - t_{EOP}) \quad (G-2)$$

* t is NavIC time at time of transmission

Appendix H. User Algorithm For Ionosphere Delay computation using Klobuchar like ionosphere coefficients

The Main terms used in computation of ionospheric delay are as follows:

H.1. Satellite Transmitted Terms

α_n - the coefficients of a cubic equation representing the amplitude of the vertical delay (4 coefficients)

β_n - the coefficients of a cubic equation representing the period of the model (4 coefficients)

The Ionospheric correction model is given by

$$T_{\text{iono}} = \begin{cases} F * \left[5.0 * 10^{-9} + (\text{AMP}) \left(1 - \frac{x^2}{2} + \frac{x^4}{24} \right) \right], & |x| < 1.57 \text{ (sec)} \\ F * (5.0 * 10^{-9}) & , |x| \geq 1.57 \end{cases}$$

where

T_{iono} is referred to the L5 frequency; if the user is operating on the L1 frequency, the correction term must be multiplied by the correction factor ($\gamma_{51} = \frac{f_{L5}^2}{f_{L1}^2}$).

$$\text{AMP} = \begin{cases} \sum_{n=0}^3 \alpha_n \phi_m^n, & \text{AMP} \geq 0 \text{ (sec)} \\ \text{if AMP} < 0, & \text{AMP} = 0 \end{cases}$$

$$x = \frac{2\pi(t-50400)}{\text{PER}} \text{ (radians)}$$

$$\text{PER} = \begin{cases} \sum_{n=0}^3 \beta_n \phi_m^n, & \text{PER} \geq 72,000 \text{ (sec)} \\ \text{if PER} < 72,000 & \text{PER} = 72,000 \end{cases}$$

$$F = 1.0 + 16.0[0.53 - E]^3$$

α_n and β_n are the satellite transmitted data words with $n=0, 1, 2,$ and 3 .

Other equations that must be solved are:

$$\phi_m = \phi_i + 0.064 \cos(\lambda_i - 1.617) \text{ (semi - circles)}$$

$$\lambda_i = \lambda_u + \frac{\psi \sin A}{\cos \phi_i} \text{ (semi - circles)}$$

$$\phi_i = \begin{cases} \phi_u + \psi \cos A & |\phi_i| \leq 0.416 \\ \text{if } \phi_i > +0.416, \text{ then } \phi_i = +0.416 & \text{(semi-circles)} \\ \text{if } \phi_i < -0.416, \text{ then } \phi_i = -0.416 & \end{cases}$$

$$\psi = \frac{0.0137}{E + 0.11} - 0.022 \quad \text{(semi-circles)}$$

$$t = 4.32 \times (10^4)\lambda_i + \text{NavIC time (sec)}$$

where,

$0 \leq t < 86400$; if $t \geq 86400$ seconds, subtract 86400 seconds

if $t < 0$ seconds, add 86400 seconds

The terms used in computation of ionospheric delay are as follows:

H.2. Receiver Generated Terms

E - Elevation angle between the user and satellite (semi-circles)

A - Azimuth angle between the user and satellite, measured clockwise positive from the true North (semi-circles)

ϕ_u - user geodetic latitude (semi-circles) WGS-84

λ_u - user geodetic longitude (semi-circles) WGS-84

NavIC time - receiver computed system time (sec)

H.3. Computed Terms

x - Phase (radians)

F - Obliquity factor (dimensionless)

t - Local time (sec)

ϕ_m - geomagnetic latitude of the earth projection of the ionospheric intersection point (mean ionospheric height assumed 350 km) (semi-circles)

λ_i - geodetic longitude of the earth projection of the ionospheric intersection point (semi-circles)

ϕ_i - geodetic latitude of the earth projection of the ionospheric intersection point (semi-circles)

ψ - earth's central angle between the user position and the earth projection of ionospheric intersection point (semi-circles).



Appendix I. (Reserved for new NavIC Iono algorithm)

Appendix J. LDPC Sub- Matrices

Table 29: LDPC Submatrix A for Subframe 2 * (sheet 1 of 9)

R , C	R , C	R , C	R , C	R , C	R , C	R , C
1 , 1	232 , 5	402 , 9	92 , 14	294 , 18	461 , 22	121 , 27
79 , 1	281 , 5	498 , 9	108 , 14	343 , 18	547 , 22	175 , 27
145 , 1	330 , 5	534 , 9	162 , 14	355 , 18	23 , 23	204 , 27
199 , 1	392 , 5	10 , 10	241 , 14	411 , 18	51 , 23	253 , 27
228 , 1	448 , 5	88 , 10	290 , 14	457 , 18	117 , 23	302 , 27
277 , 1	494 , 5	104 , 10	339 , 14	543 , 18	171 , 23	364 , 27
326 , 1	530 , 5	158 , 10	351 , 14	19 , 19	250 , 23	420 , 27
388 , 1	6 , 6	237 , 10	407 , 14	97 , 19	299 , 23	466 , 27
444 , 1	84 , 6	286 , 10	453 , 14	113 , 19	348 , 23	502 , 27
490 , 1	150 , 6	335 , 10	539 , 14	167 , 19	360 , 23	28 , 28
526 , 1	154 , 6	397 , 10	15 , 15	246 , 19	416 , 23	56 , 28
2 , 2	233 , 6	403 , 10	93 , 15	295 , 19	462 , 23	122 , 28
80 , 2	282 , 6	499 , 10	109 , 15	344 , 19	548 , 23	176 , 28
146 , 2	331 , 6	535 , 10	163 , 15	356 , 19	24 , 24	205 , 28
200 , 2	393 , 6	11 , 11	242 , 15	412 , 19	52 , 24	254 , 28
229 , 2	449 , 6	89 , 11	291 , 15	458 , 19	118 , 24	303 , 28
278 , 2	495 , 6	105 , 11	340 , 15	544 , 19	172 , 24	365 , 28
327 , 2	531 , 6	159 , 11	352 , 15	20 , 20	201 , 24	421 , 28
389 , 2	7 , 7	238 , 11	408 , 15	98 , 20	300 , 24	467 , 28
445 , 2	85 , 7	287 , 11	454 , 15	114 , 20	349 , 24	503 , 28
491 , 2	101 , 7	336 , 11	540 , 15	168 , 20	361 , 24	29 , 29
527 , 2	155 , 7	398 , 11	16 , 16	247 , 20	417 , 24	57 , 29
3 , 3	234 , 7	404 , 11	94 , 16	296 , 20	463 , 24	123 , 29
81 , 3	283 , 7	500 , 11	110 , 16	345 , 20	549 , 24	177 , 29
147 , 3	332 , 7	536 , 11	164 , 16	357 , 20	25 , 25	206 , 29
151 , 3	394 , 7	12 , 12	243 , 16	413 , 20	53 , 25	255 , 29
230 , 3	450 , 7	90 , 12	292 , 16	459 , 20	119 , 25	304 , 29
279 , 3	496 , 7	106 , 12	341 , 16	545 , 20	173 , 25	366 , 29
328 , 3	532 , 7	160 , 12	353 , 16	21 , 21	202 , 25	422 , 29
390 , 3	8 , 8	239 , 12	409 , 16	99 , 21	251 , 25	468 , 29
446 , 3	86 , 8	288 , 12	455 , 16	115 , 21	350 , 25	504 , 29
492 , 3	102 , 8	337 , 12	541 , 16	169 , 21	362 , 25	30 , 30
528 , 3	156 , 8	399 , 12	17 , 17	248 , 21	418 , 25	58 , 30
4 , 4	235 , 8	405 , 12	95 , 17	297 , 21	464 , 25	124 , 30
82 , 4	284 , 8	451 , 12	111 , 17	346 , 21	550 , 25	178 , 30
148 , 4	333 , 8	537 , 12	165 , 17	358 , 21	26 , 26	207 , 30
152 , 4	395 , 8	13 , 13	244 , 17	414 , 21	54 , 26	256 , 30
231 , 4	401 , 8	91 , 13	293 , 17	460 , 21	120 , 26	305 , 30
280 , 4	497 , 8	107 , 13	342 , 17	546 , 21	174 , 26	367 , 30
329 , 4	533 , 8	161 , 13	354 , 17	22 , 22	203 , 26	423 , 30
391 , 4	9 , 9	240 , 13	410 , 17	100 , 22	252 , 26	469 , 30
447 , 4	87 , 9	289 , 13	456 , 17	116 , 22	301 , 26	505 , 30
493 , 4	103 , 9	338 , 13	542 , 17	170 , 22	363 , 26	31 , 31
529 , 4	157 , 9	400 , 13	18 , 18	249 , 22	419 , 26	59 , 31
5 , 5	236 , 9	406 , 13	96 , 18	298 , 22	465 , 26	125 , 31
83 , 5	285 , 9	452 , 13	112 , 18	347 , 22	501 , 26	179 , 31
149 , 5	334 , 9	538 , 13	166 , 18	359 , 22	27 , 27	208 , 31
153 , 5	396 , 9	14 , 14	245 , 18	415 , 22	55 , 27	257 , 31

* Coordinates of elements with value “1” in submatrix A (550 rows, 600 columns). The coordinates are

represented as R, C where R=row and C=column.

LDPC Submatrix A for Subframe 2* (sheet 2 of 9)

R , C	R , C	R , C	R , C	R , C	R , C	R , C
306 , 31	510 , 35	188 , 40	381 , 44	49 , 49	439 , 59	405 , 75
368 , 31	36 , 36	217 , 40	437 , 44	77 , 49	60 , 60	76 , 76
424 , 31	64 , 36	266 , 40	483 , 44	143 , 49	386 , 60	352 , 76
470 , 31	130 , 36	315 , 40	519 , 44	197 , 49	440 , 60	406 , 76
506 , 31	184 , 36	377 , 40	45 , 45	226 , 49	61 , 61	77 , 77
32 , 32	213 , 36	433 , 40	73 , 45	275 , 49	387 , 61	353 , 77
60 , 32	262 , 36	479 , 40	139 , 45	324 , 49	441 , 61	407 , 77
126 , 32	311 , 36	515 , 40	193 , 45	386 , 49	62 , 62	78 , 78
180 , 32	373 , 36	41 , 41	222 , 45	442 , 49	388 , 62	354 , 78
209 , 32	429 , 36	69 , 41	271 , 45	488 , 49	442 , 62	408 , 78
258 , 32	475 , 36	135 , 41	320 , 45	524 , 49	63 , 63	79 , 79
307 , 32	511 , 36	189 , 41	382 , 45	50 , 50	389 , 63	355 , 79
369 , 32	37 , 37	218 , 41	438 , 45	78 , 50	443 , 63	409 , 79
425 , 32	65 , 37	267 , 41	484 , 45	144 , 50	64 , 64	80 , 80
471 , 32	131 , 37	316 , 41	520 , 45	198 , 50	390 , 64	356 , 80
507 , 32	185 , 37	378 , 41	46 , 46	227 , 50	444 , 64	410 , 80
33 , 33	214 , 37	434 , 41	74 , 46	276 , 50	65 , 65	81 , 81
61 , 33	263 , 37	480 , 41	140 , 46	325 , 50	391 , 65	357 , 81
127 , 33	312 , 37	516 , 41	194 , 46	387 , 50	445 , 65	411 , 81
181 , 33	374 , 37	42 , 42	223 , 46	443 , 50	66 , 66	82 , 82
210 , 33	430 , 37	70 , 42	272 , 46	489 , 50	392 , 66	358 , 82
259 , 33	476 , 37	136 , 42	321 , 46	525 , 50	446 , 66	412 , 82
308 , 33	512 , 37	190 , 42	383 , 46	51 , 51	67 , 67	83 , 83
370 , 33	38 , 38	219 , 42	439 , 46	377 , 51	393 , 67	359 , 83
426 , 33	66 , 38	268 , 42	485 , 46	431 , 51	447 , 67	413 , 83
472 , 33	132 , 38	317 , 42	521 , 46	52 , 52	68 , 68	84 , 84
508 , 33	186 , 38	379 , 42	47 , 47	378 , 52	394 , 68	360 , 84
34 , 34	215 , 38	435 , 42	75 , 47	432 , 52	448 , 68	414 , 84
62 , 34	264 , 38	481 , 42	141 , 47	53 , 53	69 , 69	85 , 85
128 , 34	313 , 38	517 , 42	195 , 47	379 , 53	395 , 69	361 , 85
182 , 34	375 , 38	43 , 43	224 , 47	433 , 53	449 , 69	415 , 85
211 , 34	431 , 38	71 , 43	273 , 47	54 , 54	70 , 70	86 , 86
260 , 34	477 , 38	137 , 43	322 , 47	380 , 54	396 , 70	362 , 86
309 , 34	513 , 38	191 , 43	384 , 47	434 , 54	450 , 70	416 , 86
371 , 34	39 , 39	220 , 43	440 , 47	55 , 55	71 , 71	87 , 87
427 , 34	67 , 39	269 , 43	486 , 47	381 , 55	397 , 71	363 , 87
473 , 34	133 , 39	318 , 43	522 , 47	435 , 55	401 , 71	417 , 87
509 , 34	187 , 39	380 , 43	48 , 48	56 , 56	72 , 72	88 , 88
35 , 35	216 , 39	436 , 43	76 , 48	382 , 56	398 , 72	364 , 88
63 , 35	265 , 39	482 , 43	142 , 48	436 , 56	402 , 72	418 , 88
129 , 35	314 , 39	518 , 43	196 , 48	57 , 57	73 , 73	89 , 89
183 , 35	376 , 39	44 , 44	225 , 48	383 , 57	399 , 73	365 , 89
212 , 35	432 , 39	72 , 44	274 , 48	437 , 57	403 , 73	419 , 89
261 , 35	478 , 39	138 , 44	323 , 48	58 , 58	74 , 74	90 , 90
310 , 35	514 , 39	192 , 44	385 , 48	384 , 58	400 , 74	366 , 90
372 , 35	40 , 40	221 , 44	441 , 48	438 , 58	404 , 74	420 , 90
428 , 35	68 , 40	270 , 44	487 , 48	59 , 59	75 , 75	91 , 91
474 , 35	134 , 40	319 , 44	523 , 48	385 , 59	351 , 75	367 , 91

* Coordinates of elements with value "1" in submatrix A (550 rows, 600 columns). The coordinates are represented as R, C where R=row and C=column.

LDPC Submatrix A for Subframe 2 * (sheet 3 of 9)

R , C	R , C	R , C	R , C	R , C	R , C	R , C
421 , 91	549 , 107	515 , 123	531 , 139	439 , 155	405 , 171	421 , 187
92 , 92	108 , 108	124 , 124	140 , 140	156 , 156	172 , 172	188 , 188
368 , 92	285 , 108	251 , 124	267 , 140	255 , 156	271 , 172	287 , 188
422 , 92	550 , 108	516 , 124	532 , 140	440 , 156	406 , 172	422 , 188
93 , 93	109 , 109	125 , 125	141 , 141	157 , 157	173 , 173	189 , 189
369 , 93	286 , 109	252 , 125	268 , 141	256 , 157	272 , 173	288 , 189
423 , 93	501 , 109	517 , 125	533 , 141	441 , 157	407 , 173	423 , 189
94 , 94	110 , 110	126 , 126	142 , 142	158 , 158	174 , 174	190 , 190
370 , 94	287 , 110	253 , 126	269 , 142	257 , 158	273 , 174	289 , 190
424 , 94	502 , 110	518 , 126	534 , 142	442 , 158	408 , 174	424 , 190
95 , 95	111 , 111	127 , 127	143 , 143	159 , 159	175 , 175	191 , 191
371 , 95	288 , 111	254 , 127	270 , 143	258 , 159	274 , 175	290 , 191
425 , 95	503 , 111	519 , 127	535 , 143	443 , 159	409 , 175	425 , 191
96 , 96	112 , 112	128 , 128	144 , 144	160 , 160	176 , 176	192 , 192
372 , 96	289 , 112	255 , 128	271 , 144	259 , 160	275 , 176	291 , 192
426 , 96	504 , 112	520 , 128	536 , 144	444 , 160	410 , 176	426 , 192
97 , 97	113 , 113	129 , 129	145 , 145	161 , 161	177 , 177	193 , 193
373 , 97	290 , 113	256 , 129	272 , 145	260 , 161	276 , 177	292 , 193
427 , 97	505 , 113	521 , 129	537 , 145	445 , 161	411 , 177	427 , 193
98 , 98	114 , 114	130 , 130	146 , 146	162 , 162	178 , 178	194 , 194
374 , 98	291 , 114	257 , 130	273 , 146	261 , 162	277 , 178	293 , 194
428 , 98	506 , 114	522 , 130	538 , 146	446 , 162	412 , 178	428 , 194
99 , 99	115 , 115	131 , 131	147 , 147	163 , 163	179 , 179	195 , 195
375 , 99	292 , 115	258 , 131	274 , 147	262 , 163	278 , 179	294 , 195
429 , 99	507 , 115	523 , 131	539 , 147	447 , 163	413 , 179	429 , 195
100 , 100	116 , 116	132 , 132	148 , 148	164 , 164	180 , 180	196 , 196
376 , 100	293 , 116	259 , 132	275 , 148	263 , 164	279 , 180	295 , 196
430 , 100	508 , 116	524 , 132	540 , 148	448 , 164	414 , 180	430 , 196
101 , 101	117 , 117	133 , 133	149 , 149	165 , 165	181 , 181	197 , 197
278 , 101	294 , 117	260 , 133	276 , 149	264 , 165	280 , 181	296 , 197
543 , 101	509 , 117	525 , 133	541 , 149	449 , 165	415 , 181	431 , 197
102 , 102	118 , 118	134 , 134	150 , 150	166 , 166	182 , 182	198 , 198
279 , 102	295 , 118	261 , 134	277 , 150	265 , 166	281 , 182	297 , 198
544 , 102	510 , 118	526 , 134	542 , 150	450 , 166	416 , 182	432 , 198
103 , 103	119 , 119	135 , 135	151 , 151	167 , 167	183 , 183	199 , 199
280 , 103	296 , 119	262 , 135	300 , 151	266 , 167	282 , 183	298 , 199
545 , 103	511 , 119	527 , 135	435 , 151	401 , 167	417 , 183	433 , 199
104 , 104	120 , 120	136 , 136	152 , 152	168 , 168	184 , 184	200 , 200
281 , 104	297 , 120	263 , 136	251 , 152	267 , 168	283 , 184	299 , 200
546 , 104	512 , 120	528 , 136	436 , 152	402 , 168	418 , 184	434 , 200
105 , 105	121 , 121	137 , 137	153 , 153	169 , 169	185 , 185	1 , 201
282 , 105	298 , 121	264 , 137	252 , 153	268 , 169	284 , 185	84 , 201
547 , 105	513 , 121	529 , 137	437 , 153	403 , 169	419 , 185	141 , 201
106 , 106	122 , 122	138 , 138	154 , 154	170 , 170	186 , 186	181 , 201
283 , 106	299 , 122	265 , 138	253 , 154	269 , 170	285 , 186	248 , 201
548 , 106	514 , 122	530 , 138	438 , 154	404 , 170	420 , 186	284 , 201
107 , 107	123 , 123	139 , 139	155 , 155	171 , 171	187 , 187	343 , 201
284 , 107	300 , 123	266 , 139	254 , 155	270 , 171	286 , 187	351 , 201
* Coordinates of elements with value "1" in submatrix A (550 rows, 600 columns). The coordinates are represented as R, C where R=row and C=column.						

LDPC Submatrix A for Subframe 2 * (sheet 4 of 9)

R , C	R , C	R , C	R , C	R , C	R , C	R , C
429 , 201	89 , 206	293 , 210	495 , 214	109 , 219	315 , 223	504 , 227
482 , 201	146 , 206	302 , 210	541 , 214	199 , 219	373 , 223	28 , 228
528 , 201	186 , 206	360 , 210	15 , 215	216 , 219	401 , 223	61 , 228
2 , 202	203 , 206	438 , 210	98 , 215	252 , 219	454 , 223	118 , 228
85 , 202	289 , 206	491 , 210	105 , 215	311 , 219	550 , 223	158 , 228
142 , 202	348 , 206	537 , 210	195 , 215	369 , 219	24 , 224	225 , 228
182 , 202	356 , 206	11 , 211	212 , 215	447 , 219	57 , 224	261 , 228
249 , 202	434 , 206	94 , 211	298 , 215	500 , 219	114 , 224	320 , 228
285 , 202	487 , 206	101 , 211	307 , 215	546 , 219	154 , 224	378 , 228
344 , 202	533 , 206	191 , 211	365 , 215	20 , 220	221 , 224	406 , 228
352 , 202	7 , 207	208 , 211	443 , 215	53 , 220	257 , 224	459 , 228
430 , 202	90 , 207	294 , 211	496 , 215	110 , 220	316 , 224	505 , 228
483 , 202	147 , 207	303 , 211	542 , 215	200 , 220	374 , 224	29 , 229
529 , 202	187 , 207	361 , 211	16 , 216	217 , 220	402 , 224	62 , 229
3 , 203	204 , 207	439 , 211	99 , 216	253 , 220	455 , 224	119 , 229
86 , 203	290 , 207	492 , 211	106 , 216	312 , 220	501 , 224	159 , 229
143 , 203	349 , 207	538 , 211	196 , 216	370 , 220	25 , 225	226 , 229
183 , 203	357 , 207	12 , 212	213 , 216	448 , 220	58 , 225	262 , 229
250 , 203	435 , 207	95 , 212	299 , 216	451 , 220	115 , 225	321 , 229
286 , 203	488 , 207	102 , 212	308 , 216	547 , 220	155 , 225	379 , 229
345 , 203	534 , 207	192 , 212	366 , 216	21 , 221	222 , 225	407 , 229
353 , 203	8 , 208	209 , 212	444 , 216	54 , 221	258 , 225	460 , 229
431 , 203	91 , 208	295 , 212	497 , 216	111 , 221	317 , 225	506 , 229
484 , 203	148 , 208	304 , 212	543 , 216	151 , 221	375 , 225	30 , 230
530 , 203	188 , 208	362 , 212	17 , 217	218 , 221	403 , 225	63 , 230
4 , 204	205 , 208	440 , 212	100 , 217	254 , 221	456 , 225	120 , 230
87 , 204	291 , 208	493 , 212	107 , 217	313 , 221	502 , 225	160 , 230
144 , 204	350 , 208	539 , 212	197 , 217	371 , 221	26 , 226	227 , 230
184 , 204	358 , 208	13 , 213	214 , 217	449 , 221	59 , 226	263 , 230
201 , 204	436 , 208	96 , 213	300 , 217	452 , 221	116 , 226	322 , 230
287 , 204	489 , 208	103 , 213	309 , 217	548 , 221	156 , 226	380 , 230
346 , 204	535 , 208	193 , 213	367 , 217	22 , 222	223 , 226	408 , 230
354 , 204	9 , 209	210 , 213	445 , 217	55 , 222	259 , 226	461 , 230
432 , 204	92 , 209	296 , 213	498 , 217	112 , 222	318 , 226	507 , 230
485 , 204	149 , 209	305 , 213	544 , 217	152 , 222	376 , 226	31 , 231
531 , 204	189 , 209	363 , 213	18 , 218	219 , 222	404 , 226	64 , 231
5 , 205	206 , 209	441 , 213	51 , 218	255 , 222	457 , 226	121 , 231
88 , 205	292 , 209	494 , 213	108 , 218	314 , 222	503 , 226	161 , 231
145 , 205	301 , 209	540 , 213	198 , 218	372 , 222	27 , 227	228 , 231
185 , 205	359 , 209	14 , 214	215 , 218	450 , 222	60 , 227	264 , 231
202 , 205	437 , 209	97 , 214	251 , 218	453 , 222	117 , 227	323 , 231
288 , 205	490 , 209	104 , 214	310 , 218	549 , 222	157 , 227	381 , 231
347 , 205	536 , 209	194 , 214	368 , 218	23 , 223	224 , 227	409 , 231
355 , 205	10 , 210	211 , 214	446 , 218	56 , 223	260 , 227	462 , 231
433 , 205	93 , 210	297 , 214	499 , 218	113 , 223	319 , 227	508 , 231
486 , 205	150 , 210	306 , 214	545 , 218	153 , 223	377 , 227	32 , 232
532 , 205	190 , 210	364 , 214	19 , 219	220 , 223	405 , 227	65 , 232
6 , 206	207 , 210	442 , 214	52 , 219	256 , 223	458 , 227	122 , 232
* Coordinates of elements with value "1" in submatrix A (550 rows, 600 columns). The coordinates are represented as R, C where R=row and C=column.						

LDPC Submatrix A for Subframe 2 * (sheet 5 of 9)

R , C	R , C	R , C	R , C	R , C	R , C	R , C
162 , 232	386 , 236	41 , 241	242 , 245	427 , 249	402 , 262	418 , 278
229 , 232	414 , 236	74 , 241	278 , 245	480 , 249	544 , 262	510 , 278
265 , 232	467 , 236	131 , 241	337 , 245	526 , 249	13 , 263	29 , 279
324 , 232	513 , 236	171 , 241	395 , 245	50 , 250	403 , 263	419 , 279
382 , 232	37 , 237	238 , 241	423 , 245	83 , 250	545 , 263	511 , 279
410 , 232	70 , 237	274 , 241	476 , 245	140 , 250	14 , 264	30 , 280
463 , 232	127 , 237	333 , 241	522 , 245	180 , 250	404 , 264	420 , 280
509 , 232	167 , 237	391 , 241	46 , 246	247 , 250	546 , 264	512 , 280
33 , 233	234 , 237	419 , 241	79 , 246	283 , 250	15 , 265	31 , 281
66 , 233	270 , 237	472 , 241	136 , 246	342 , 250	405 , 265	421 , 281
123 , 233	329 , 237	518 , 241	176 , 246	400 , 250	547 , 265	513 , 281
163 , 233	387 , 237	42 , 242	243 , 246	428 , 250	16 , 266	32 , 282
230 , 233	415 , 237	75 , 242	279 , 246	481 , 250	406 , 266	422 , 282
266 , 233	468 , 237	132 , 242	338 , 246	527 , 250	548 , 266	514 , 282
325 , 233	514 , 237	172 , 242	396 , 246	1 , 251	17 , 267	33 , 283
383 , 233	38 , 238	239 , 242	424 , 246	441 , 251	407 , 267	423 , 283
411 , 233	71 , 238	275 , 242	477 , 246	533 , 251	549 , 267	515 , 283
464 , 233	128 , 238	334 , 242	523 , 246	2 , 252	18 , 268	34 , 284
510 , 233	168 , 238	392 , 242	47 , 247	442 , 252	408 , 268	424 , 284
34 , 234	235 , 238	420 , 242	80 , 247	534 , 252	550 , 268	516 , 284
67 , 234	271 , 238	473 , 242	137 , 247	3 , 253	19 , 269	35 , 285
124 , 234	330 , 238	519 , 242	177 , 247	443 , 253	409 , 269	425 , 285
164 , 234	388 , 238	43 , 243	244 , 247	535 , 253	501 , 269	517 , 285
231 , 234	416 , 238	76 , 243	280 , 247	4 , 254	20 , 270	36 , 286
267 , 234	469 , 238	133 , 243	339 , 247	444 , 254	410 , 270	426 , 286
326 , 234	515 , 238	173 , 243	397 , 247	536 , 254	502 , 270	518 , 286
384 , 234	39 , 239	240 , 243	425 , 247	5 , 255	21 , 271	37 , 287
412 , 234	72 , 239	276 , 243	478 , 247	445 , 255	411 , 271	427 , 287
465 , 234	129 , 239	335 , 243	524 , 247	537 , 255	503 , 271	519 , 287
511 , 234	169 , 239	393 , 243	48 , 248	6 , 256	22 , 272	38 , 288
35 , 235	236 , 239	421 , 243	81 , 248	446 , 256	412 , 272	428 , 288
68 , 235	272 , 239	474 , 243	138 , 248	538 , 256	504 , 272	520 , 288
125 , 235	331 , 239	520 , 243	178 , 248	7 , 257	23 , 273	39 , 289
165 , 235	389 , 239	44 , 244	245 , 248	447 , 257	413 , 273	429 , 289
232 , 235	417 , 239	77 , 244	281 , 248	539 , 257	505 , 273	521 , 289
268 , 235	470 , 239	134 , 244	340 , 248	8 , 258	24 , 274	40 , 290
327 , 235	516 , 239	174 , 244	398 , 248	448 , 258	414 , 274	430 , 290
385 , 235	40 , 240	241 , 244	426 , 248	540 , 258	506 , 274	522 , 290
413 , 235	73 , 240	277 , 244	479 , 248	9 , 259	25 , 275	41 , 291
466 , 235	130 , 240	336 , 244	525 , 248	449 , 259	415 , 275	431 , 291
512 , 235	170 , 240	394 , 244	49 , 249	541 , 259	507 , 275	523 , 291
36 , 236	237 , 240	422 , 244	82 , 249	10 , 260	26 , 276	42 , 292
69 , 236	273 , 240	475 , 244	139 , 249	450 , 260	416 , 276	432 , 292
126 , 236	332 , 240	521 , 244	179 , 249	542 , 260	508 , 276	524 , 292
166 , 236	390 , 240	45 , 245	246 , 249	11 , 261	27 , 277	43 , 293
233 , 236	418 , 240	78 , 245	282 , 249	401 , 261	417 , 277	433 , 293
269 , 236	471 , 240	135 , 245	341 , 249	543 , 261	509 , 277	525 , 293
328 , 236	517 , 240	175 , 245	399 , 249	12 , 262	28 , 278	44 , 294
* Coordinates of elements with value "1" in submatrix A (550 rows, 600 columns). The coordinates are represented as R, C where R=row and C=column.						

LDPC Submatrix A for Subframe 2 * (sheet 6 of 9)

R , C	R , C	R , C	R , C	R , C	R , C	R , C
434 , 294	257 , 310	273 , 326	289 , 342	62 , 362	86 , 386	396 , 402
526 , 294	352 , 310	368 , 326	384 , 342	548 , 362	522 , 386	429 , 402
45 , 295	61 , 311	77 , 327	93 , 343	63 , 363	87 , 387	489 , 402
435 , 295	258 , 311	274 , 327	290 , 343	549 , 363	523 , 387	543 , 402
527 , 295	353 , 311	369 , 327	385 , 343	64 , 364	88 , 388	3 , 403
46 , 296	62 , 312	78 , 328	94 , 344	550 , 364	524 , 388	91 , 403
436 , 296	259 , 312	275 , 328	291 , 344	65 , 365	89 , 389	129 , 403
528 , 296	354 , 312	370 , 328	386 , 344	501 , 365	525 , 389	178 , 403
47 , 297	63 , 313	79 , 329	95 , 345	66 , 366	90 , 390	203 , 403
437 , 297	260 , 313	276 , 329	292 , 345	502 , 366	526 , 390	293 , 403
529 , 297	355 , 313	371 , 329	387 , 345	67 , 367	91 , 391	346 , 403
48 , 298	64 , 314	80 , 330	96 , 346	503 , 367	527 , 391	397 , 403
438 , 298	261 , 314	277 , 330	293 , 346	68 , 368	92 , 392	430 , 403
530 , 298	356 , 314	372 , 330	388 , 346	504 , 368	528 , 392	490 , 403
49 , 299	65 , 315	81 , 331	97 , 347	69 , 369	93 , 393	544 , 403
439 , 299	262 , 315	278 , 331	294 , 347	505 , 369	529 , 393	4 , 404
531 , 299	357 , 315	373 , 331	389 , 347	70 , 370	94 , 394	92 , 404
50 , 300	66 , 316	82 , 332	98 , 348	506 , 370	530 , 394	130 , 404
440 , 300	263 , 316	279 , 332	295 , 348	71 , 371	95 , 395	179 , 404
532 , 300	358 , 316	374 , 332	390 , 348	507 , 371	531 , 395	204 , 404
51 , 301	67 , 317	83 , 333	99 , 349	72 , 372	96 , 396	294 , 404
298 , 301	264 , 317	280 , 333	296 , 349	508 , 372	532 , 396	347 , 404
393 , 301	359 , 317	375 , 333	391 , 349	73 , 373	97 , 397	398 , 404
52 , 302	68 , 318	84 , 334	100 , 350	509 , 373	533 , 397	431 , 404
299 , 302	265 , 318	281 , 334	297 , 350	74 , 374	98 , 398	491 , 404
394 , 302	360 , 318	376 , 334	392 , 350	510 , 374	534 , 398	545 , 404
53 , 303	69 , 319	85 , 335	51 , 351	75 , 375	99 , 399	5 , 405
300 , 303	266 , 319	282 , 335	537 , 351	511 , 375	535 , 399	93 , 405
395 , 303	361 , 319	377 , 335	52 , 352	76 , 376	100 , 400	131 , 405
54 , 304	70 , 320	86 , 336	538 , 352	512 , 376	536 , 400	180 , 405
251 , 304	267 , 320	283 , 336	53 , 353	77 , 377	1 , 401	205 , 405
396 , 304	362 , 320	378 , 336	539 , 353	513 , 377	89 , 401	295 , 405
55 , 305	71 , 321	87 , 337	54 , 354	78 , 378	127 , 401	348 , 405
252 , 305	268 , 321	284 , 337	540 , 354	514 , 378	176 , 401	399 , 405
397 , 305	363 , 321	379 , 337	55 , 355	79 , 379	201 , 401	432 , 405
56 , 306	72 , 322	88 , 338	541 , 355	515 , 379	291 , 401	492 , 405
253 , 306	269 , 322	285 , 338	56 , 356	80 , 380	344 , 401	546 , 405
398 , 306	364 , 322	380 , 338	542 , 356	516 , 380	395 , 401	6 , 406
57 , 307	73 , 323	89 , 339	57 , 357	81 , 381	428 , 401	94 , 406
254 , 307	270 , 323	286 , 339	543 , 357	517 , 381	488 , 401	132 , 406
399 , 307	365 , 323	381 , 339	58 , 358	82 , 382	542 , 401	181 , 406
58 , 308	74 , 324	90 , 340	544 , 358	518 , 382	2 , 402	206 , 406
255 , 308	271 , 324	287 , 340	59 , 359	83 , 383	90 , 402	296 , 406
400 , 308	366 , 324	382 , 340	545 , 359	519 , 383	128 , 402	349 , 406
59 , 309	75 , 325	91 , 341	60 , 360	84 , 384	177 , 402	400 , 406
256 , 309	272 , 325	288 , 341	546 , 360	520 , 384	202 , 402	433 , 406
351 , 309	367 , 325	383 , 341	61 , 361	85 , 385	292 , 402	493 , 406
60 , 310	76 , 326	92 , 342	547 , 361	521 , 385	345 , 402	547 , 406

* Coordinates of elements with value “1” in submatrix A (550 rows, 600 columns). The coordinates are represented as R, C where R=row and C=column.

LDPC Submatrix A for Subframe 2 * (sheet 7 of 9)

R , C	R , C	R , C	R , C	R , C	R , C	R , C
7 , 407	211 , 411	442 , 415	58 , 420	264 , 424	465 , 428	109 , 433
95 , 407	251 , 411	452 , 415	146 , 420	317 , 424	519 , 428	158 , 433
133 , 407	304 , 411	506 , 415	195 , 420	368 , 424	29 , 429	233 , 433
182 , 407	355 , 411	16 , 416	220 , 420	401 , 424	67 , 429	273 , 433
207 , 407	438 , 411	54 , 416	260 , 420	461 , 424	105 , 429	326 , 433
297 , 407	498 , 411	142 , 416	313 , 420	515 , 424	154 , 429	377 , 433
350 , 407	502 , 411	191 , 416	364 , 420	25 , 425	229 , 429	410 , 433
351 , 407	12 , 412	216 , 416	447 , 420	63 , 425	269 , 429	470 , 433
434 , 407	100 , 412	256 , 416	457 , 420	101 , 425	322 , 429	524 , 433
494 , 407	138 , 412	309 , 416	511 , 420	200 , 425	373 , 429	34 , 434
548 , 407	187 , 412	360 , 416	21 , 421	225 , 425	406 , 429	72 , 434
8 , 408	212 , 412	443 , 416	59 , 421	265 , 425	466 , 429	110 , 434
96 , 408	252 , 412	453 , 416	147 , 421	318 , 425	520 , 429	159 , 434
134 , 408	305 , 412	507 , 416	196 , 421	369 , 425	30 , 430	234 , 434
183 , 408	356 , 412	17 , 417	221 , 421	402 , 425	68 , 430	274 , 434
208 , 408	439 , 412	55 , 417	261 , 421	462 , 425	106 , 430	327 , 434
298 , 408	499 , 412	143 , 417	314 , 421	516 , 425	155 , 430	378 , 434
301 , 408	503 , 412	192 , 417	365 , 421	26 , 426	230 , 430	411 , 434
352 , 408	13 , 413	217 , 417	448 , 421	64 , 426	270 , 430	471 , 434
435 , 408	51 , 413	257 , 417	458 , 421	102 , 426	323 , 430	525 , 434
495 , 408	139 , 413	310 , 417	512 , 421	151 , 426	374 , 430	35 , 435
549 , 408	188 , 413	361 , 417	22 , 422	226 , 426	407 , 430	73 , 435
9 , 409	213 , 413	444 , 417	60 , 422	266 , 426	467 , 430	111 , 435
97 , 409	253 , 413	454 , 417	148 , 422	319 , 426	521 , 430	160 , 435
135 , 409	306 , 413	508 , 417	197 , 422	370 , 426	31 , 431	235 , 435
184 , 409	357 , 413	18 , 418	222 , 422	403 , 426	69 , 431	275 , 435
209 , 409	440 , 413	56 , 418	262 , 422	463 , 426	107 , 431	328 , 435
299 , 409	500 , 413	144 , 418	315 , 422	517 , 426	156 , 431	379 , 435
302 , 409	504 , 413	193 , 418	366 , 422	27 , 427	231 , 431	412 , 435
353 , 409	14 , 414	218 , 418	449 , 422	65 , 427	271 , 431	472 , 435
436 , 409	52 , 414	258 , 418	459 , 422	103 , 427	324 , 431	526 , 435
496 , 409	140 , 414	311 , 418	513 , 422	152 , 427	375 , 431	36 , 436
550 , 409	189 , 414	362 , 418	23 , 423	227 , 427	408 , 431	74 , 436
10 , 410	214 , 414	445 , 418	61 , 423	267 , 427	468 , 431	112 , 436
98 , 410	254 , 414	455 , 418	149 , 423	320 , 427	522 , 431	161 , 436
136 , 410	307 , 414	509 , 418	198 , 423	371 , 427	32 , 432	236 , 436
185 , 410	358 , 414	19 , 419	223 , 423	404 , 427	70 , 432	276 , 436
210 , 410	441 , 414	57 , 419	263 , 423	464 , 427	108 , 432	329 , 436
300 , 410	451 , 414	145 , 419	316 , 423	518 , 427	157 , 432	380 , 436
303 , 410	505 , 414	194 , 419	367 , 423	28 , 428	232 , 432	413 , 436
354 , 410	15 , 415	219 , 419	450 , 423	66 , 428	272 , 432	473 , 436
437 , 410	53 , 415	259 , 419	460 , 423	104 , 428	325 , 432	527 , 436
497 , 410	141 , 415	312 , 419	514 , 423	153 , 428	376 , 432	37 , 437
501 , 410	190 , 415	363 , 419	24 , 424	228 , 428	409 , 432	75 , 437
11 , 411	215 , 415	446 , 419	62 , 424	268 , 428	469 , 432	113 , 437
99 , 411	255 , 415	456 , 419	150 , 424	321 , 428	523 , 432	162 , 437
137 , 411	308 , 415	510 , 419	199 , 424	372 , 428	33 , 433	237 , 437
186 , 411	359 , 415	20 , 420	224 , 424	405 , 428	71 , 433	277 , 437
* Coordinates of elements with value "1" in submatrix A (550 rows, 600 columns). The coordinates are represented as R, C where R=row and C=column.						

LDPC Submatrix A for Subframe 2 * (sheet 8 of 9)

R , C	R , C	R , C	R , C	R , C	R , C	R , C
330 , 437	532 , 441	171 , 446	394 , 450	173 , 473	197 , 497	205 , 514
381 , 437	42 , 442	246 , 446	427 , 450	305 , 473	329 , 497	461 , 514
414 , 437	80 , 442	286 , 446	487 , 450	174 , 474	198 , 498	115 , 515
474 , 437	118 , 442	339 , 446	541 , 450	306 , 474	330 , 498	206 , 515
528 , 437	167 , 442	390 , 446	151 , 451	175 , 475	199 , 499	462 , 515
38 , 438	242 , 442	423 , 446	333 , 451	307 , 475	331 , 499	116 , 516
76 , 438	282 , 442	483 , 446	152 , 452	176 , 476	200 , 500	207 , 516
114 , 438	335 , 442	537 , 446	334 , 452	308 , 476	332 , 500	463 , 516
163 , 438	386 , 442	47 , 447	153 , 453	177 , 477	101 , 501	117 , 517
238 , 438	419 , 442	85 , 447	335 , 453	309 , 477	242 , 501	208 , 517
278 , 438	479 , 442	123 , 447	154 , 454	178 , 478	498 , 501	464 , 517
331 , 438	533 , 442	172 , 447	336 , 454	310 , 478	102 , 502	118 , 518
382 , 438	43 , 443	247 , 447	155 , 455	179 , 479	243 , 502	209 , 518
415 , 438	81 , 443	287 , 447	337 , 455	311 , 479	499 , 502	465 , 518
475 , 438	119 , 443	340 , 447	156 , 456	180 , 480	103 , 503	119 , 519
529 , 438	168 , 443	391 , 447	338 , 456	312 , 480	244 , 503	210 , 519
39 , 439	243 , 443	424 , 447	157 , 457	181 , 481	500 , 503	466 , 519
77 , 439	283 , 443	484 , 447	339 , 457	313 , 481	104 , 504	120 , 520
115 , 439	336 , 443	538 , 447	158 , 458	182 , 482	245 , 504	211 , 520
164 , 439	387 , 443	48 , 448	340 , 458	314 , 482	451 , 504	467 , 520
239 , 439	420 , 443	86 , 448	159 , 459	183 , 483	105 , 505	121 , 521
279 , 439	480 , 443	124 , 448	341 , 459	315 , 483	246 , 505	212 , 521
332 , 439	534 , 443	173 , 448	160 , 460	184 , 484	452 , 505	468 , 521
383 , 439	44 , 444	248 , 448	342 , 460	316 , 484	106 , 506	122 , 522
416 , 439	82 , 444	288 , 448	161 , 461	185 , 485	247 , 506	213 , 522
476 , 439	120 , 444	341 , 448	343 , 461	317 , 485	453 , 506	469 , 522
530 , 439	169 , 444	392 , 448	162 , 462	186 , 486	107 , 507	123 , 523
40 , 440	244 , 444	425 , 448	344 , 462	318 , 486	248 , 507	214 , 523
78 , 440	284 , 444	485 , 448	163 , 463	187 , 487	454 , 507	470 , 523
116 , 440	337 , 444	539 , 448	345 , 463	319 , 487	108 , 508	124 , 524
165 , 440	388 , 444	49 , 449	164 , 464	188 , 488	249 , 508	215 , 524
240 , 440	421 , 444	87 , 449	346 , 464	320 , 488	455 , 508	471 , 524
280 , 440	481 , 444	125 , 449	165 , 465	189 , 489	109 , 509	125 , 525
333 , 440	535 , 444	174 , 449	347 , 465	321 , 489	250 , 509	216 , 525
384 , 440	45 , 445	249 , 449	166 , 466	190 , 490	456 , 509	472 , 525
417 , 440	83 , 445	289 , 449	348 , 466	322 , 490	110 , 510	126 , 526
477 , 440	121 , 445	342 , 449	167 , 467	191 , 491	201 , 510	217 , 526
531 , 440	170 , 445	393 , 449	349 , 467	323 , 491	457 , 510	473 , 526
41 , 441	245 , 445	426 , 449	168 , 468	192 , 492	111 , 511	127 , 527
79 , 441	285 , 445	486 , 449	350 , 468	324 , 492	202 , 511	218 , 527
117 , 441	338 , 445	540 , 449	169 , 469	193 , 493	458 , 511	474 , 527
166 , 441	389 , 445	50 , 450	301 , 469	325 , 493	112 , 512	128 , 528
241 , 441	422 , 445	88 , 450	170 , 470	194 , 494	203 , 512	219 , 528
281 , 441	482 , 445	126 , 450	302 , 470	326 , 494	459 , 512	475 , 528
334 , 441	536 , 445	175 , 450	171 , 471	195 , 495	113 , 513	129 , 529
385 , 441	46 , 446	250 , 450	303 , 471	327 , 495	204 , 513	220 , 529
418 , 441	84 , 446	290 , 450	172 , 472	196 , 496	460 , 513	476 , 529
478 , 441	122 , 446	343 , 450	304 , 472	328 , 496	114 , 514	130 , 530
* Coordinates of elements with value "1" in submatrix A (550 rows, 600 columns). The coordinates are represented as R, C where R=row and C=column.						

LDPC Submatrix A for Subframe 2 * (sheet 9 of 9)

R , C	R , C	R , C	R , C	R , C	R , C	R , C
221 , 530	487 , 540	1 , 551	250 , 561	454 , 571	32 , 582	231 , 592
477 , 530	141 , 541	240 , 551	494 , 561	22 , 572	221 , 582	475 , 592
131 , 531	232 , 541	484 , 551	12 , 562	211 , 572	465 , 582	43 , 593
222 , 531	488 , 541	2 , 552	201 , 562	455 , 572	33 , 583	232 , 593
478 , 531	142 , 542	241 , 552	495 , 562	23 , 573	222 , 583	476 , 593
132 , 532	233 , 542	485 , 552	13 , 563	212 , 573	466 , 583	44 , 594
223 , 532	489 , 542	3 , 553	202 , 563	456 , 573	34 , 584	233 , 594
479 , 532	143 , 543	242 , 553	496 , 563	24 , 574	223 , 584	477 , 594
133 , 533	234 , 543	486 , 553	14 , 564	213 , 574	467 , 584	45 , 595
224 , 533	490 , 543	4 , 554	203 , 564	457 , 574	35 , 585	234 , 595
480 , 533	144 , 544	243 , 554	497 , 564	25 , 575	224 , 585	478 , 595
134 , 534	235 , 544	487 , 554	15 , 565	214 , 575	468 , 585	46 , 596
225 , 534	491 , 544	5 , 555	204 , 565	458 , 575	36 , 586	235 , 596
481 , 534	145 , 545	244 , 555	498 , 565	26 , 576	225 , 586	479 , 596
135 , 535	236 , 545	488 , 555	16 , 566	215 , 576	469 , 586	47 , 597
226 , 535	492 , 545	6 , 556	205 , 566	459 , 576	37 , 587	236 , 597
482 , 535	146 , 546	245 , 556	499 , 566	27 , 577	226 , 587	480 , 597
136 , 536	237 , 546	489 , 556	17 , 567	216 , 577	470 , 587	48 , 598
227 , 536	493 , 546	7 , 557	206 , 567	460 , 577	38 , 588	237 , 598
483 , 536	147 , 547	246 , 557	500 , 567	28 , 578	227 , 588	481 , 598
137 , 537	238 , 547	490 , 557	18 , 568	217 , 578	471 , 588	49 , 599
228 , 537	494 , 547	8 , 558	207 , 568	461 , 578	39 , 589	238 , 599
484 , 537	148 , 548	247 , 558	451 , 568	29 , 579	228 , 589	482 , 599
138 , 538	239 , 548	491 , 558	19 , 569	218 , 579	472 , 589	50 , 600
229 , 538	495 , 548	9 , 559	208 , 569	462 , 579	40 , 590	239 , 600
485 , 538	149 , 549	248 , 559	452 , 569	30 , 580	229 , 590	483 , 600
139 , 539	240 , 549	492 , 559	20 , 570	219 , 580	473 , 590	
230 , 539	496 , 549	10 , 560	209 , 570	463 , 580	41 , 591	
486 , 539	150 , 550	249 , 560	453 , 570	31 , 581	230 , 591	
140 , 540	241 , 550	493 , 560	21 , 571	220 , 581	474 , 591	
231 , 540	497 , 550	11 , 561	210 , 571	464 , 581	42 , 592	

* Coordinates of elements with value “1” in submatrix A (550 rows, 600 columns). The coordinates are represented as R, C where R=row and C=column.

Table 30: LDPC Submatrix B for Subframe 2 *

R , C	R , C	R , C	R , C	R , C	R , C	R , C
50 , 1	308 , 8	15 , 16	323 , 23	30 , 31	338 , 38	45 , 46
301 , 1	8 , 9	316 , 16	23 , 24	331 , 31	38 , 39	346 , 46
1 , 2	309 , 9	16 , 17	324 , 24	31 , 32	339 , 39	46 , 47
302 , 2	9 , 10	317 , 17	24 , 25	332 , 32	39 , 40	347 , 47
2 , 3	310 , 10	17 , 18	325 , 25	32 , 33	340 , 40	47 , 48
303 , 3	10 , 11	318 , 18	25 , 26	333 , 33	40 , 41	348 , 48
3 , 4	311 , 11	18 , 19	326 , 26	33 , 34	341 , 41	48 , 49
304 , 4	11 , 12	319 , 19	26 , 27	334 , 34	41 , 42	349 , 49
4 , 5	312 , 12	19 , 20	327 , 27	34 , 35	342 , 42	49 , 50
305 , 5	12 , 13	320 , 20	27 , 28	335 , 35	42 , 43	350 , 50
5 , 6	313 , 13	20 , 21	328 , 28	35 , 36	343 , 43	
306 , 6	13 , 14	321 , 21	28 , 29	336 , 36	43 , 44	
6 , 7	314 , 14	21 , 22	329 , 29	36 , 37	344 , 44	
307 , 7	14 , 15	322 , 22	29 , 30	337 , 37	44 , 45	
7 , 8	315 , 15	22 , 23	330 , 30	37 , 38	345 , 45	

* Coordinates of elements with value “1” in submatrix B (550 rows, 50 columns). The coordinates are represented as R, C where R=row and C=column.

Table 31: LDPC Submatrix C for Subframe 2 *

R , C	R , C	R , C	R , C	R , C	R , C	R , C
48 , 1	34 , 37	7 , 223	7 , 359	43 , 395	6 , 431	12 , 467
49 , 2	35 , 38	8 , 224	8 , 360	44 , 396	7 , 432	13 , 468
50 , 3	36 , 39	9 , 225	9 , 361	45 , 397	8 , 433	14 , 469
1 , 4	37 , 40	10 , 226	10 , 362	46 , 398	9 , 434	15 , 470
2 , 5	38 , 41	11 , 227	11 , 363	47 , 399	10 , 435	16 , 471
3 , 6	39 , 42	12 , 228	12 , 364	48 , 400	11 , 436	17 , 472
4 , 7	40 , 43	13 , 229	13 , 365	26 , 401	12 , 437	18 , 473
5 , 8	41 , 44	14 , 230	14 , 366	27 , 402	13 , 438	19 , 474
6 , 9	42 , 45	15 , 231	15 , 367	28 , 403	14 , 439	20 , 475
7 , 10	43 , 46	16 , 232	16 , 368	29 , 404	15 , 440	21 , 476
8 , 11	44 , 47	17 , 233	17 , 369	30 , 405	16 , 441	22 , 477
9 , 12	45 , 48	18 , 234	18 , 370	31 , 406	17 , 442	23 , 478
10 , 13	46 , 49	19 , 235	19 , 371	32 , 407	18 , 443	24 , 479
11 , 14	47 , 50	20 , 236	20 , 372	33 , 408	19 , 444	25 , 480
12 , 15	35 , 201	21 , 237	21 , 373	34 , 409	20 , 445	26 , 481
13 , 16	36 , 202	22 , 238	22 , 374	35 , 410	21 , 446	27 , 482
14 , 17	37 , 203	23 , 239	23 , 375	36 , 411	22 , 447	28 , 483
15 , 18	38 , 204	24 , 240	24 , 376	37 , 412	23 , 448	29 , 484
16 , 19	39 , 205	25 , 241	25 , 377	38 , 413	24 , 449	30 , 485
17 , 20	40 , 206	26 , 242	26 , 378	39 , 414	25 , 450	31 , 486
18 , 21	41 , 207	27 , 243	27 , 379	40 , 415	46 , 451	32 , 487
19 , 22	42 , 208	28 , 244	28 , 380	41 , 416	47 , 452	33 , 488
20 , 23	43 , 209	29 , 245	29 , 381	42 , 417	48 , 453	34 , 489
21 , 24	44 , 210	30 , 246	30 , 382	43 , 418	49 , 454	35 , 490
22 , 25	45 , 211	31 , 247	31 , 383	44 , 419	50 , 455	36 , 491
23 , 26	46 , 212	32 , 248	32 , 384	45 , 420	1 , 456	37 , 492
24 , 27	47 , 213	33 , 249	33 , 385	46 , 421	2 , 457	38 , 493
25 , 28	48 , 214	34 , 250	34 , 386	47 , 422	3 , 458	39 , 494
26 , 29	49 , 215	49 , 351	35 , 387	48 , 423	4 , 459	40 , 495
27 , 30	50 , 216	50 , 352	36 , 388	49 , 424	5 , 460	41 , 496
28 , 31	1 , 217	1 , 353	37 , 389	50 , 425	6 , 461	42 , 497
29 , 32	2 , 218	2 , 354	38 , 390	1 , 426	7 , 462	43 , 498
30 , 33	3 , 219	3 , 355	39 , 391	2 , 427	8 , 463	44 , 499
31 , 34	4 , 220	4 , 356	40 , 392	3 , 428	9 , 464	45 , 500
32 , 35	5 , 221	5 , 357	41 , 393	4 , 429	10 , 465	
33 , 36	6 , 222	6 , 358	42 , 394	5 , 430	11 , 466	

* Coordinates of elements with value “1” in submatrix C (50 rows, 600 columns). The coordinates are represented as R, C where R=row and C=column.

Table 32: LDPC Submatrix D for Subframe 2 *

R , C	R , C	R , C	R , C	R , C	R , C	R , C
50 , 1	8 , 9	16 , 17	24 , 25	32 , 33	40 , 41	48 , 49
1 , 2	9 , 10	17 , 18	25 , 26	33 , 34	41 , 42	49 , 50
2 , 3	10 , 11	18 , 19	26 , 27	34 , 35	42 , 43	
3 , 4	11 , 12	19 , 20	27 , 28	35 , 36	43 , 44	
4 , 5	12 , 13	20 , 21	28 , 29	36 , 37	44 , 45	
5 , 6	13 , 14	21 , 22	29 , 30	37 , 38	45 , 46	
6 , 7	14 , 15	22 , 23	30 , 31	38 , 39	46 , 47	
7 , 8	15 , 16	23 , 24	31 , 32	39 , 40	47 , 48	

* Coordinates of elements with value “1” in submatrix D (50 rows, 50 columns). The coordinates are represented as R, C where R=row and C=column.

Table 33: LDPC Submatrix E for Subframe 2 *

R , C	R , C	R , C	R , C	R , C	R , C	R , C
1 , 501	9 , 509	17 , 517	25 , 525	33 , 533	41 , 541	49 , 549
2 , 502	10 , 510	18 , 518	26 , 526	34 , 534	42 , 542	50 , 550
3 , 503	11 , 511	19 , 519	27 , 527	35 , 535	43 , 543	
4 , 504	12 , 512	20 , 520	28 , 528	36 , 536	44 , 544	
5 , 505	13 , 513	21 , 521	29 , 529	37 , 537	45 , 545	
6 , 506	14 , 514	22 , 522	30 , 530	38 , 538	46 , 546	
7 , 507	15 , 515	23 , 523	31 , 531	39 , 539	47 , 547	
8 , 508	16 , 516	24 , 524	32 , 532	40 , 540	48 , 548	
* Coordinates of elements with value “1” in submatrix E (50 rows, 550 columns). The coordinates are represented as R, C where R=row and C=column.						

Table 34: LDPC Submatrix T for Subframe 2 * (sheet 1 of 4)

R , C	R , C	R , C	R , C	R , C	R , C	R , C
1 , 1	25 , 25	49 , 49	73 , 73	97 , 97	121 , 121	145 , 145
51 , 1	75 , 25	99 , 49	123 , 73	147 , 97	171 , 121	195 , 145
2 , 2	26 , 26	50 , 50	74 , 74	98 , 98	122 , 122	146 , 146
52 , 2	76 , 26	100 , 50	124 , 74	148 , 98	172 , 122	196 , 146
3 , 3	27 , 27	51 , 51	75 , 75	99 , 99	123 , 123	147 , 147
53 , 3	77 , 27	101 , 51	125 , 75	149 , 99	173 , 123	197 , 147
4 , 4	28 , 28	52 , 52	76 , 76	100 , 100	124 , 124	148 , 148
54 , 4	78 , 28	102 , 52	126 , 76	150 , 100	174 , 124	198 , 148
5 , 5	29 , 29	53 , 53	77 , 77	101 , 101	125 , 125	149 , 149
55 , 5	79 , 29	103 , 53	127 , 77	151 , 101	175 , 125	199 , 149
6 , 6	30 , 30	54 , 54	78 , 78	102 , 102	126 , 126	150 , 150
56 , 6	80 , 30	104 , 54	128 , 78	152 , 102	176 , 126	200 , 150
7 , 7	31 , 31	55 , 55	79 , 79	103 , 103	127 , 127	151 , 151
57 , 7	81 , 31	105 , 55	129 , 79	153 , 103	177 , 127	201 , 151
8 , 8	32 , 32	56 , 56	80 , 80	104 , 104	128 , 128	152 , 152
58 , 8	82 , 32	106 , 56	130 , 80	154 , 104	178 , 128	202 , 152
9 , 9	33 , 33	57 , 57	81 , 81	105 , 105	129 , 129	153 , 153
59 , 9	83 , 33	107 , 57	131 , 81	155 , 105	179 , 129	203 , 153
10 , 10	34 , 34	58 , 58	82 , 82	106 , 106	130 , 130	154 , 154
60 , 10	84 , 34	108 , 58	132 , 82	156 , 106	180 , 130	204 , 154
11 , 11	35 , 35	59 , 59	83 , 83	107 , 107	131 , 131	155 , 155
61 , 11	85 , 35	109 , 59	133 , 83	157 , 107	181 , 131	205 , 155
12 , 12	36 , 36	60 , 60	84 , 84	108 , 108	132 , 132	156 , 156
62 , 12	86 , 36	110 , 60	134 , 84	158 , 108	182 , 132	206 , 156
13 , 13	37 , 37	61 , 61	85 , 85	109 , 109	133 , 133	157 , 157
63 , 13	87 , 37	111 , 61	135 , 85	159 , 109	183 , 133	207 , 157
14 , 14	38 , 38	62 , 62	86 , 86	110 , 110	134 , 134	158 , 158
64 , 14	88 , 38	112 , 62	136 , 86	160 , 110	184 , 134	208 , 158
15 , 15	39 , 39	63 , 63	87 , 87	111 , 111	135 , 135	159 , 159
65 , 15	89 , 39	113 , 63	137 , 87	161 , 111	185 , 135	209 , 159
16 , 16	40 , 40	64 , 64	88 , 88	112 , 112	136 , 136	160 , 160
66 , 16	90 , 40	114 , 64	138 , 88	162 , 112	186 , 136	210 , 160
17 , 17	41 , 41	65 , 65	89 , 89	113 , 113	137 , 137	161 , 161
67 , 17	91 , 41	115 , 65	139 , 89	163 , 113	187 , 137	211 , 161
18 , 18	42 , 42	66 , 66	90 , 90	114 , 114	138 , 138	162 , 162
68 , 18	92 , 42	116 , 66	140 , 90	164 , 114	188 , 138	212 , 162
19 , 19	43 , 43	67 , 67	91 , 91	115 , 115	139 , 139	163 , 163
69 , 19	93 , 43	117 , 67	141 , 91	165 , 115	189 , 139	213 , 163
20 , 20	44 , 44	68 , 68	92 , 92	116 , 116	140 , 140	164 , 164
70 , 20	94 , 44	118 , 68	142 , 92	166 , 116	190 , 140	214 , 164
21 , 21	45 , 45	69 , 69	93 , 93	117 , 117	141 , 141	165 , 165
71 , 21	95 , 45	119 , 69	143 , 93	167 , 117	191 , 141	215 , 165
22 , 22	46 , 46	70 , 70	94 , 94	118 , 118	142 , 142	166 , 166
72 , 22	96 , 46	120 , 70	144 , 94	168 , 118	192 , 142	216 , 166
23 , 23	47 , 47	71 , 71	95 , 95	119 , 119	143 , 143	167 , 167
73 , 23	97 , 47	121 , 71	145 , 95	169 , 119	193 , 143	217 , 167
24 , 24	48 , 48	72 , 72	96 , 96	120 , 120	144 , 144	168 , 168
74 , 24	98 , 48	122 , 72	146 , 96	170 , 120	194 , 144	218 , 168
* Coordinates of elements with value "1" in submatrix T (550 rows, 550 columns). The coordinates are represented as R, C where R=row and C=column.						

LDPC Submatrix T for Subframe 2 * (sheet 2 of 4)

R , C	R , C	R , C	R , C	R , C	R , C	R , C
169 , 169	193 , 193	217 , 217	241 , 241	265 , 265	289 , 289	313 , 313
219 , 169	243 , 193	267 , 217	291 , 241	315 , 265	339 , 289	363 , 313
170 , 170	194 , 194	218 , 218	242 , 242	266 , 266	290 , 290	314 , 314
220 , 170	244 , 194	268 , 218	292 , 242	316 , 266	340 , 290	364 , 314
171 , 171	195 , 195	219 , 219	243 , 243	267 , 267	291 , 291	315 , 315
221 , 171	245 , 195	269 , 219	293 , 243	317 , 267	341 , 291	365 , 315
172 , 172	196 , 196	220 , 220	244 , 244	268 , 268	292 , 292	316 , 316
222 , 172	246 , 196	270 , 220	294 , 244	318 , 268	342 , 292	366 , 316
173 , 173	197 , 197	221 , 221	245 , 245	269 , 269	293 , 293	317 , 317
223 , 173	247 , 197	271 , 221	295 , 245	319 , 269	343 , 293	367 , 317
174 , 174	198 , 198	222 , 222	246 , 246	270 , 270	294 , 294	318 , 318
224 , 174	248 , 198	272 , 222	296 , 246	320 , 270	344 , 294	368 , 318
175 , 175	199 , 199	223 , 223	247 , 247	271 , 271	295 , 295	319 , 319
225 , 175	249 , 199	273 , 223	297 , 247	321 , 271	345 , 295	369 , 319
176 , 176	200 , 200	224 , 224	248 , 248	272 , 272	296 , 296	320 , 320
226 , 176	250 , 200	274 , 224	298 , 248	322 , 272	346 , 296	370 , 320
177 , 177	201 , 201	225 , 225	249 , 249	273 , 273	297 , 297	321 , 321
227 , 177	251 , 201	275 , 225	299 , 249	323 , 273	347 , 297	371 , 321
178 , 178	202 , 202	226 , 226	250 , 250	274 , 274	298 , 298	322 , 322
228 , 178	252 , 202	276 , 226	300 , 250	324 , 274	348 , 298	372 , 322
179 , 179	203 , 203	227 , 227	251 , 251	275 , 275	299 , 299	323 , 323
229 , 179	253 , 203	277 , 227	301 , 251	325 , 275	349 , 299	373 , 323
180 , 180	204 , 204	228 , 228	252 , 252	276 , 276	300 , 300	324 , 324
230 , 180	254 , 204	278 , 228	302 , 252	326 , 276	350 , 300	374 , 324
181 , 181	205 , 205	229 , 229	253 , 253	277 , 277	301 , 301	325 , 325
231 , 181	255 , 205	279 , 229	303 , 253	327 , 277	351 , 301	375 , 325
182 , 182	206 , 206	230 , 230	254 , 254	278 , 278	302 , 302	326 , 326
232 , 182	256 , 206	280 , 230	304 , 254	328 , 278	352 , 302	376 , 326
183 , 183	207 , 207	231 , 231	255 , 255	279 , 279	303 , 303	327 , 327
233 , 183	257 , 207	281 , 231	305 , 255	329 , 279	353 , 303	377 , 327
184 , 184	208 , 208	232 , 232	256 , 256	280 , 280	304 , 304	328 , 328
234 , 184	258 , 208	282 , 232	306 , 256	330 , 280	354 , 304	378 , 328
185 , 185	209 , 209	233 , 233	257 , 257	281 , 281	305 , 305	329 , 329
235 , 185	259 , 209	283 , 233	307 , 257	331 , 281	355 , 305	379 , 329
186 , 186	210 , 210	234 , 234	258 , 258	282 , 282	306 , 306	330 , 330
236 , 186	260 , 210	284 , 234	308 , 258	332 , 282	356 , 306	380 , 330
187 , 187	211 , 211	235 , 235	259 , 259	283 , 283	307 , 307	331 , 331
237 , 187	261 , 211	285 , 235	309 , 259	333 , 283	357 , 307	381 , 331
188 , 188	212 , 212	236 , 236	260 , 260	284 , 284	308 , 308	332 , 332
238 , 188	262 , 212	286 , 236	310 , 260	334 , 284	358 , 308	382 , 332
189 , 189	213 , 213	237 , 237	261 , 261	285 , 285	309 , 309	333 , 333
239 , 189	263 , 213	287 , 237	311 , 261	335 , 285	359 , 309	383 , 333
190 , 190	214 , 214	238 , 238	262 , 262	286 , 286	310 , 310	334 , 334
240 , 190	264 , 214	288 , 238	312 , 262	336 , 286	360 , 310	384 , 334
191 , 191	215 , 215	239 , 239	263 , 263	287 , 287	311 , 311	335 , 335
241 , 191	265 , 215	289 , 239	313 , 263	337 , 287	361 , 311	385 , 335
192 , 192	216 , 216	240 , 240	264 , 264	288 , 288	312 , 312	336 , 336
242 , 192	266 , 216	290 , 240	314 , 264	338 , 288	362 , 312	386 , 336
* Coordinates of elements with value "1" in submatrix T (550 rows, 550 columns). The coordinates are represented as R, C where R=row and C=column.						

LDPC Submatrix T for Subframe 2 * (sheet 3 of 4)

R , C	R , C	R , C	R , C	R , C	R , C	R , C
337 , 337	361 , 361	385 , 385	409 , 409	433 , 433	457 , 457	481 , 481
387 , 337	411 , 361	435 , 385	459 , 409	483 , 433	507 , 457	531 , 481
338 , 338	362 , 362	386 , 386	410 , 410	434 , 434	458 , 458	482 , 482
388 , 338	412 , 362	436 , 386	460 , 410	484 , 434	508 , 458	532 , 482
339 , 339	363 , 363	387 , 387	411 , 411	435 , 435	459 , 459	483 , 483
389 , 339	413 , 363	437 , 387	461 , 411	485 , 435	509 , 459	533 , 483
340 , 340	364 , 364	388 , 388	412 , 412	436 , 436	460 , 460	484 , 484
390 , 340	414 , 364	438 , 388	462 , 412	486 , 436	510 , 460	534 , 484
341 , 341	365 , 365	389 , 389	413 , 413	437 , 437	461 , 461	485 , 485
391 , 341	415 , 365	439 , 389	463 , 413	487 , 437	511 , 461	535 , 485
342 , 342	366 , 366	390 , 390	414 , 414	438 , 438	462 , 462	486 , 486
392 , 342	416 , 366	440 , 390	464 , 414	488 , 438	512 , 462	536 , 486
343 , 343	367 , 367	391 , 391	415 , 415	439 , 439	463 , 463	487 , 487
393 , 343	417 , 367	441 , 391	465 , 415	489 , 439	513 , 463	537 , 487
344 , 344	368 , 368	392 , 392	416 , 416	440 , 440	464 , 464	488 , 488
394 , 344	418 , 368	442 , 392	466 , 416	490 , 440	514 , 464	538 , 488
345 , 345	369 , 369	393 , 393	417 , 417	441 , 441	465 , 465	489 , 489
395 , 345	419 , 369	443 , 393	467 , 417	491 , 441	515 , 465	539 , 489
346 , 346	370 , 370	394 , 394	418 , 418	442 , 442	466 , 466	490 , 490
396 , 346	420 , 370	444 , 394	468 , 418	492 , 442	516 , 466	540 , 490
347 , 347	371 , 371	395 , 395	419 , 419	443 , 443	467 , 467	491 , 491
397 , 347	421 , 371	445 , 395	469 , 419	493 , 443	517 , 467	541 , 491
348 , 348	372 , 372	396 , 396	420 , 420	444 , 444	468 , 468	492 , 492
398 , 348	422 , 372	446 , 396	470 , 420	494 , 444	518 , 468	542 , 492
349 , 349	373 , 373	397 , 397	421 , 421	445 , 445	469 , 469	493 , 493
399 , 349	423 , 373	447 , 397	471 , 421	495 , 445	519 , 469	543 , 493
350 , 350	374 , 374	398 , 398	422 , 422	446 , 446	470 , 470	494 , 494
400 , 350	424 , 374	448 , 398	472 , 422	496 , 446	520 , 470	544 , 494
351 , 351	375 , 375	399 , 399	423 , 423	447 , 447	471 , 471	495 , 495
401 , 351	425 , 375	449 , 399	473 , 423	497 , 447	521 , 471	545 , 495
352 , 352	376 , 376	400 , 400	424 , 424	448 , 448	472 , 472	496 , 496
402 , 352	426 , 376	450 , 400	474 , 424	498 , 448	522 , 472	546 , 496
353 , 353	377 , 377	401 , 401	425 , 425	449 , 449	473 , 473	497 , 497
403 , 353	427 , 377	451 , 401	475 , 425	499 , 449	523 , 473	547 , 497
354 , 354	378 , 378	402 , 402	426 , 426	450 , 450	474 , 474	498 , 498
404 , 354	428 , 378	452 , 402	476 , 426	500 , 450	524 , 474	548 , 498
355 , 355	379 , 379	403 , 403	427 , 427	451 , 451	475 , 475	499 , 499
405 , 355	429 , 379	453 , 403	477 , 427	501 , 451	525 , 475	549 , 499
356 , 356	380 , 380	404 , 404	428 , 428	452 , 452	476 , 476	500 , 500
406 , 356	430 , 380	454 , 404	478 , 428	502 , 452	526 , 476	550 , 500
357 , 357	381 , 381	405 , 405	429 , 429	453 , 453	477 , 477	501 , 501
407 , 357	431 , 381	455 , 405	479 , 429	503 , 453	527 , 477	502 , 502
358 , 358	382 , 382	406 , 406	430 , 430	454 , 454	478 , 478	503 , 503
408 , 358	432 , 382	456 , 406	480 , 430	504 , 454	528 , 478	504 , 504
359 , 359	383 , 383	407 , 407	431 , 431	455 , 455	479 , 479	505 , 505
409 , 359	433 , 383	457 , 407	481 , 431	505 , 455	529 , 479	506 , 506
360 , 360	384 , 384	408 , 408	432 , 432	456 , 456	480 , 480	507 , 507
410 , 360	434 , 384	458 , 408	482 , 432	506 , 456	530 , 480	508 , 508

* Coordinates of elements with value "1" in submatrix T (550 rows, 550 columns). The coordinates are represented as R, C where R=row and C=column.

LDPC Submatrix T for Subframe 2 * (sheet 4 of 4)

R , C	R , C	R , C	R , C	R , C	R , C	R , C
509 , 509	515 , 515	521 , 521	527 , 527	533 , 533	539 , 539	545 , 545
510 , 510	516 , 516	522 , 522	528 , 528	534 , 534	540 , 540	546 , 546
511 , 511	517 , 517	523 , 523	529 , 529	535 , 535	541 , 541	547 , 547
512 , 512	518 , 518	524 , 524	530 , 530	536 , 536	542 , 542	548 , 548
513 , 513	519 , 519	525 , 525	531 , 531	537 , 537	543 , 543	549 , 549
514 , 514	520 , 520	526 , 526	532 , 532	538 , 538	544 , 544	550 , 550
* Coordinates of elements with value "1" in submatrix T (550 rows, 550 columns). The coordinates are represented as R, C where R=row and C=column.						

Table 35: LDPC Submatrix A for Subframe 3 * (sheet 1 of 4)

R , C	R , C	R , C	R , C	R , C	R , C	R , C
3 , 1	99 , 5	188 , 9	40 , 14	134 , 18	169 , 30	117 , 46
27 , 1	121 , 5	207 , 9	56 , 14	156 , 18	196 , 30	247 , 46
66 , 1	143 , 5	239 , 9	83 , 14	168 , 18	33 , 31	49 , 47
70 , 1	178 , 5	12 , 10	108 , 14	197 , 18	170 , 31	118 , 47
95 , 1	184 , 5	36 , 10	130 , 14	216 , 18	197 , 31	248 , 47
117 , 1	226 , 5	52 , 10	152 , 14	248 , 18	34 , 32	50 , 48
139 , 1	235 , 5	79 , 10	164 , 14	21 , 19	171 , 32	119 , 48
174 , 1	8 , 6	104 , 10	193 , 14	22 , 19	198 , 32	249 , 48
203 , 1	32 , 6	126 , 10	212 , 14	61 , 19	35 , 33	51 , 49
222 , 1	48 , 6	148 , 10	244 , 14	88 , 19	172 , 33	120 , 49
231 , 1	75 , 6	160 , 10	17 , 15	113 , 19	199 , 33	250 , 49
4 , 2	100 , 6	189 , 10	41 , 15	135 , 19	36 , 34	52 , 50
28 , 2	122 , 6	208 , 10	57 , 15	157 , 19	173 , 34	121 , 50
67 , 2	144 , 6	240 , 10	84 , 15	169 , 19	200 , 34	251 , 50
71 , 2	179 , 6	13 , 11	109 , 15	198 , 19	37 , 35	53 , 51
96 , 2	185 , 6	37 , 11	131 , 15	217 , 19	174 , 35	122 , 51
118 , 2	227 , 6	53 , 11	153 , 15	249 , 19	201 , 35	229 , 51
140 , 2	236 , 6	80 , 11	165 , 15	22 , 20	38 , 36	54 , 52
175 , 2	9 , 7	105 , 11	194 , 15	182 , 20	175 , 36	123 , 52
204 , 2	33 , 7	127 , 11	213 , 15	186 , 20	202 , 36	230 , 52
223 , 2	49 , 7	149 , 11	245 , 15	23 , 21	39 , 37	55 , 53
232 , 2	76 , 7	161 , 11	18 , 16	160 , 21	176 , 37	124 , 53
5 , 3	101 , 7	190 , 11	42 , 16	187 , 21	203 , 37	231 , 53
29 , 3	123 , 7	209 , 11	58 , 16	24 , 22	40 , 38	56 , 54
45 , 3	145 , 7	241 , 11	85 , 16	161 , 22	177 , 38	125 , 54
72 , 3	180 , 7	14 , 12	110 , 16	188 , 22	204 , 38	232 , 54
97 , 3	186 , 7	38 , 12	132 , 16	25 , 23	41 , 39	57 , 55
119 , 3	228 , 7	54 , 12	154 , 16	162 , 23	178 , 39	126 , 55
141 , 3	237 , 7	81 , 12	166 , 16	189 , 23	205 , 39	233 , 55
176 , 3	10 , 8	106 , 12	195 , 16	26 , 24	42 , 40	58 , 56
205 , 3	34 , 8	128 , 12	214 , 16	163 , 24	179 , 40	127 , 56
224 , 3	50 , 8	150 , 12	246 , 16	190 , 24	183 , 40	234 , 56
233 , 3	77 , 8	162 , 12	19 , 17	27 , 25	43 , 41	59 , 57
6 , 4	102 , 8	191 , 12	43 , 17	164 , 25	180 , 41	128 , 57
30 , 4	124 , 8	210 , 12	59 , 17	191 , 25	184 , 41	235 , 57
46 , 4	146 , 8	242 , 12	86 , 17	28 , 26	44 , 42	60 , 58
73 , 4	181 , 8	15 , 13	111 , 17	165 , 26	181 , 42	129 , 58
98 , 4	187 , 8	39 , 13	133 , 17	192 , 26	185 , 42	236 , 58
120 , 4	206 , 8	55 , 13	155 , 17	29 , 27	45 , 43	61 , 59
142 , 4	238 , 8	82 , 13	167 , 17	166 , 27	114 , 43	130 , 59
177 , 4	11 , 9	107 , 13	196 , 17	193 , 27	244 , 43	237 , 59
183 , 4	35 , 9	129 , 13	215 , 17	30 , 28	46 , 44	62 , 60
225 , 4	51 , 9	151 , 13	247 , 17	167 , 28	115 , 44	131 , 60
234 , 4	78 , 9	163 , 13	20 , 18	194 , 28	245 , 44	238 , 60
7 , 5	103 , 9	192 , 13	44 , 18	31 , 29	47 , 45	63 , 61
31 , 5	125 , 9	211 , 13	60 , 18	168 , 29	116 , 45	132 , 61
47 , 5	147 , 9	243 , 13	87 , 18	195 , 29	246 , 45	239 , 61
74 , 5	182 , 9	16 , 14	112 , 18	32 , 30	48 , 46	64 , 62
* Coordinates of elements with value “1” in submatrix A (251 rows, 274 columns). The coordinates are represented as R, C where R=row and C=column.						

LDPC Submatrix A for Subframe 3 * (sheet 2 of 4)

R , C	R , C	R , C	R , C	R , C	R , C	R , C
133 , 62	125 , 78	211 , 90	166 , 95	131 , 100	51 , 105	204 , 109
240 , 62	202 , 78	230 , 90	190 , 95	140 , 100	104 , 105	207 , 109
65 , 63	81 , 79	1 , 91	216 , 95	171 , 100	136 , 105	249 , 109
134 , 63	126 , 79	30 , 91	235 , 95	195 , 100	145 , 105	20 , 110
241 , 63	203 , 79	60 , 91	6 , 96	221 , 100	176 , 105	26 , 110
66 , 64	82 , 80	113 , 91	35 , 96	240 , 100	200 , 105	56 , 110
135 , 64	127 , 80	122 , 91	65 , 96	11 , 101	226 , 105	69 , 110
242 , 64	204 , 80	154 , 91	95 , 96	40 , 101	245 , 105	109 , 110
67 , 65	83 , 81	162 , 91	127 , 96	47 , 101	16 , 106	118 , 110
136 , 65	128 , 81	186 , 91	159 , 96	100 , 101	22 , 106	150 , 110
243 , 65	205 , 81	212 , 91	167 , 96	132 , 101	52 , 106	181 , 110
68 , 66	84 , 82	231 , 91	191 , 96	141 , 101	105 , 106	205 , 110
136 , 66	129 , 82	2 , 92	217 , 96	172 , 101	114 , 106	208 , 110
190 , 66	183 , 82	31 , 92	236 , 96	196 , 101	146 , 106	250 , 110
69 , 67	85 , 83	61 , 92	7 , 97	222 , 101	177 , 106	21 , 111
114 , 67	130 , 83	91 , 92	36 , 97	241 , 101	201 , 106	27 , 111
191 , 67	184 , 83	123 , 92	66 , 97	12 , 102	227 , 106	57 , 111
70 , 68	86 , 84	155 , 92	96 , 97	41 , 102	246 , 106	110 , 111
115 , 68	131 , 84	163 , 92	128 , 97	48 , 102	17 , 107	119 , 111
192 , 68	185 , 84	187 , 92	137 , 97	101 , 102	23 , 107	151 , 111
71 , 69	87 , 85	213 , 92	168 , 97	133 , 102	53 , 107	182 , 111
116 , 69	132 , 85	232 , 92	192 , 97	142 , 102	89 , 107	183 , 111
193 , 69	186 , 85	3 , 93	218 , 97	173 , 102	106 , 107	209 , 111
72 , 70	88 , 86	32 , 93	237 , 97	197 , 102	115 , 107	251 , 111
117 , 70	133 , 86	62 , 93	8 , 98	223 , 102	147 , 107	196 , 112
194 , 70	187 , 86	92 , 93	37 , 98	242 , 102	178 , 107	234 , 112
73 , 71	89 , 87	124 , 93	67 , 98	13 , 103	202 , 107	197 , 113
118 , 71	134 , 87	156 , 93	97 , 98	42 , 103	228 , 107	235 , 113
195 , 71	188 , 87	164 , 93	129 , 98	49 , 103	247 , 107	1 , 114
74 , 72	90 , 88	188 , 93	138 , 98	102 , 103	18 , 108	198 , 114
119 , 72	135 , 88	214 , 93	169 , 98	134 , 103	24 , 108	236 , 114
196 , 72	189 , 88	233 , 93	193 , 98	143 , 103	54 , 108	2 , 115
75 , 73	28 , 89	4 , 94	219 , 98	174 , 103	90 , 108	199 , 115
120 , 73	58 , 89	33 , 94	238 , 98	198 , 103	107 , 108	237 , 115
197 , 73	111 , 89	63 , 94	9 , 99	224 , 103	116 , 108	3 , 116
76 , 74	120 , 89	93 , 94	38 , 99	243 , 103	148 , 108	200 , 116
121 , 74	152 , 89	125 , 94	45 , 99	14 , 104	179 , 108	238 , 116
198 , 74	160 , 89	157 , 94	98 , 99	43 , 104	203 , 108	4 , 117
77 , 75	184 , 89	165 , 94	130 , 99	50 , 104	206 , 108	201 , 117
122 , 75	210 , 89	189 , 94	139 , 99	103 , 104	248 , 108	239 , 117
199 , 75	229 , 89	215 , 94	170 , 99	135 , 104	19 , 109	5 , 118
78 , 76	29 , 90	234 , 94	194 , 99	144 , 104	25 , 109	202 , 118
123 , 76	59 , 90	5 , 95	220 , 99	175 , 104	55 , 109	240 , 118
200 , 76	112 , 90	34 , 95	239 , 99	199 , 104	68 , 109	6 , 119
79 , 77	121 , 90	64 , 95	10 , 100	225 , 104	108 , 109	203 , 119
124 , 77	153 , 90	94 , 95	39 , 100	244 , 104	117 , 109	241 , 119
201 , 77	161 , 90	126 , 95	46 , 100	15 , 105	149 , 109	7 , 120
80 , 78	185 , 90	158 , 95	99 , 100	44 , 105	180 , 109	204 , 120

* Coordinates of elements with value "1" in submatrix A (251 rows, 274 columns). The coordinates are represented as R, C where R=row and C=column.

LDPC Submatrix A for Subframe 3 * (sheet 3 of 4)

R , C	R , C	R , C	R , C	R , C	R , C	R , C
242 , 120	176 , 136	169 , 152	38 , 174	3 , 185	226 , 191	147 , 198
8 , 121	24 , 137	40 , 153	231 , 174	37 , 185	10 , 192	171 , 198
205 , 121	136 , 137	129 , 153	39 , 175	48 , 185	44 , 192	200 , 198
243 , 121	177 , 137	170 , 153	232 , 175	131 , 185	55 , 192	210 , 198
9 , 122	25 , 138	41 , 154	40 , 176	157 , 185	115 , 192	17 , 199
183 , 122	114 , 138	130 , 154	233 , 176	181 , 185	141 , 192	28 , 199
244 , 122	178 , 138	171 , 154	41 , 177	220 , 185	165 , 192	62 , 199
10 , 123	26 , 139	42 , 155	234 , 177	4 , 186	227 , 192	122 , 199
184 , 123	115 , 139	131 , 155	42 , 178	38 , 186	11 , 193	148 , 199
245 , 123	179 , 139	172 , 155	235 , 178	49 , 186	22 , 193	172 , 199
11 , 124	27 , 140	43 , 156	43 , 179	132 , 186	56 , 193	201 , 199
185 , 124	116 , 140	132 , 156	236 , 179	158 , 186	116 , 193	211 , 199
246 , 124	180 , 140	173 , 156	44 , 180	182 , 186	142 , 193	18 , 200
12 , 125	28 , 141	44 , 157	237 , 180	221 , 186	166 , 193	29 , 200
186 , 125	117 , 141	133 , 157	33 , 181	5 , 187	228 , 193	63 , 200
247 , 125	181 , 141	174 , 157	67 , 181	39 , 187	12 , 194	123 , 200
13 , 126	29 , 142	22 , 158	89 , 181	50 , 187	23 , 194	149 , 200
187 , 126	118 , 142	238 , 158	91 , 181	133 , 187	57 , 194	173 , 200
248 , 126	182 , 142	23 , 159	127 , 181	159 , 187	117 , 194	202 , 200
14 , 127	30 , 143	239 , 159	153 , 181	160 , 187	143 , 194	212 , 200
188 , 127	119 , 143	24 , 160	177 , 181	222 , 187	167 , 194	19 , 201
249 , 127	160 , 143	240 , 160	216 , 181	6 , 188	206 , 194	30 , 201
15 , 128	31 , 144	25 , 161	34 , 182	40 , 188	13 , 195	64 , 201
189 , 128	120 , 144	241 , 161	45 , 182	51 , 188	24 , 195	124 , 201
250 , 128	161 , 144	26 , 162	90 , 182	134 , 188	58 , 195	150 , 201
16 , 129	32 , 145	242 , 162	92 , 182	137 , 188	118 , 195	174 , 201
190 , 129	121 , 145	27 , 163	128 , 182	161 , 188	144 , 195	213 , 201
251 , 129	162 , 145	243 , 163	154 , 182	223 , 188	168 , 195	20 , 202
17 , 130	33 , 146	28 , 164	178 , 182	7 , 189	207 , 195	31 , 202
191 , 130	122 , 146	244 , 164	217 , 182	41 , 189	14 , 196	65 , 202
229 , 130	163 , 146	29 , 165	1 , 183	52 , 189	25 , 196	125 , 202
18 , 131	34 , 147	245 , 165	35 , 183	135 , 189	59 , 196	151 , 202
192 , 131	123 , 147	30 , 166	46 , 183	138 , 189	119 , 196	175 , 202
230 , 131	164 , 147	246 , 166	68 , 183	162 , 189	145 , 196	214 , 202
19 , 132	35 , 148	31 , 167	93 , 183	224 , 189	169 , 196	21 , 203
193 , 132	124 , 148	247 , 167	129 , 183	8 , 190	208 , 196	32 , 203
231 , 132	165 , 148	32 , 168	155 , 183	42 , 190	15 , 197	66 , 203
20 , 133	36 , 149	248 , 168	179 , 183	53 , 190	26 , 197	126 , 203
194 , 133	125 , 149	33 , 169	218 , 183	136 , 190	60 , 197	152 , 203
232 , 133	166 , 149	249 , 169	2 , 184	139 , 190	120 , 197	176 , 203
21 , 134	37 , 150	34 , 170	36 , 184	163 , 190	146 , 197	215 , 203
195 , 134	126 , 150	250 , 170	47 , 184	225 , 190	170 , 197	68 , 204
233 , 134	167 , 150	35 , 171	69 , 184	9 , 191	199 , 197	142 , 204
22 , 135	38 , 151	251 , 171	94 , 184	43 , 191	209 , 197	69 , 205
134 , 135	127 , 151	36 , 172	130 , 184	54 , 191	16 , 198	143 , 205
175 , 135	168 , 151	229 , 172	156 , 184	114 , 191	27 , 198	70 , 206
23 , 136	39 , 152	37 , 173	180 , 184	140 , 191	61 , 198	144 , 206
135 , 136	128 , 152	230 , 173	219 , 184	164 , 191	121 , 198	71 , 207

* Coordinates of elements with value “1” in submatrix A (251 rows, 274 columns). The coordinates are represented as R, C where R=row and C=column.

LDPC Submatrix A for Subframe 3 * (sheet 4 of 4)

R , C	R , C	R , C	R , C	R , C	R , C	R , C
145 , 207	158 , 220	109 , 231	58 , 240	224 , 248	7 , 258	228 , 266
72 , 208	85 , 221	207 , 231	95 , 240	67 , 249	111 , 258	16 , 267
146 , 208	159 , 221	50 , 232	216 , 240	104 , 249	220 , 258	97 , 267
73 , 209	86 , 222	110 , 232	59 , 241	225 , 249	8 , 259	206 , 267
147 , 209	137 , 222	208 , 232	96 , 241	103 , 250	112 , 259	17 , 268
74 , 210	87 , 223	51 , 233	217 , 241	212 , 250	221 , 259	98 , 268
148 , 210	138 , 223	111 , 233	60 , 242	104 , 251	9 , 260	207 , 268
75 , 211	88 , 224	209 , 233	97 , 242	213 , 251	113 , 260	18 , 269
149 , 211	139 , 224	52 , 234	218 , 242	1 , 252	222 , 260	99 , 269
76 , 212	89 , 225	112 , 234	61 , 243	105 , 252	10 , 261	208 , 269
150 , 212	140 , 225	210 , 234	98 , 243	214 , 252	91 , 261	19 , 270
77 , 213	90 , 226	53 , 235	219 , 243	2 , 253	223 , 261	100 , 270
151 , 213	141 , 226	113 , 235	62 , 244	106 , 253	11 , 262	209 , 270
78 , 214	45 , 227	211 , 235	99 , 244	215 , 253	92 , 262	20 , 271
152 , 214	105 , 227	54 , 236	220 , 244	3 , 254	224 , 262	101 , 271
79 , 215	226 , 227	91 , 236	63 , 245	107 , 254	12 , 263	210 , 271
153 , 215	46 , 228	212 , 236	100 , 245	216 , 254	93 , 263	21 , 272
80 , 216	106 , 228	55 , 237	221 , 245	4 , 255	225 , 263	102 , 272
154 , 216	227 , 228	92 , 237	64 , 246	108 , 255	13 , 264	211 , 272
81 , 217	47 , 229	213 , 237	101 , 246	217 , 255	94 , 264	21 , 273
155 , 217	107 , 229	56 , 238	222 , 246	5 , 256	226 , 264	137 , 273
82 , 218	228 , 229	93 , 238	65 , 247	109 , 256	14 , 265	138 , 274
156 , 218	48 , 230	214 , 238	102 , 247	218 , 256	95 , 265	
83 , 219	108 , 230	57 , 239	223 , 247	6 , 257	227 , 265	
157 , 219	206 , 230	94 , 239	66 , 248	110 , 257	15 , 266	
84 , 220	49 , 231	215 , 239	103 , 248	219 , 257	96 , 266	

* Coordinates of elements with value “1” in submatrix A (251 rows, 274 columns). The coordinates are represented as R, C where R=row and C=column.

Table 36: LDPC Submatrix B for Subframe 3 *

R , C	R , C	R , C	R , C	R , C	R , C	R , C
139 , 1	4 , 5	146 , 8	11 , 12	153 , 15	18 , 19	23 , 23
1 , 2	143 , 5	8 , 9	150 , 12	15 , 16	157 , 19	
140 , 2	5 , 6	147 , 9	12 , 13	154 , 16	19 , 20	
2 , 3	144 , 6	9 , 10	151 , 13	16 , 17	158 , 20	
141 , 3	6 , 7	148 , 10	13 , 14	155 , 17	20 , 21	
3 , 4	145 , 7	10 , 11	152 , 14	17 , 18	159 , 21	
142 , 4	7 , 8	149 , 11	14 , 15	156 , 18	22 , 22	

* Coordinates of elements with value “1” in submatrix B (251 rows, 23 columns). The coordinates are represented as R, C where R=row and C=column.

Table 37: LDPC Submatrix C for Subframe 3 *

R , C	R , C	R , C	R , C	R , C	R , C	R , C
2 , 1	19 , 18	23 , 104	8 , 167	2 , 184	19 , 201	10 , 218
3 , 2	20 , 19	1 , 105	9 , 168	3 , 185	20 , 202	11 , 219
4 , 3	8 , 89	2 , 106	10 , 169	4 , 186	21 , 203	12 , 220
5 , 4	9 , 90	3 , 107	11 , 170	5 , 187	19 , 204	13 , 221
6 , 5	10 , 91	4 , 108	12 , 171	6 , 188	20 , 205	14 , 222
7 , 6	11 , 92	5 , 109	13 , 172	7 , 189	21 , 206	15 , 223
8 , 7	12 , 93	6 , 110	14 , 173	8 , 190	22 , 207	16 , 224
9 , 8	13 , 94	7 , 111	15 , 174	9 , 191	23 , 208	17 , 225
10 , 9	14 , 95	22 , 158	16 , 175	10 , 192	1 , 209	18 , 226
11 , 10	15 , 96	23 , 159	17 , 176	11 , 193	2 , 210	23 , 273
12 , 11	16 , 97	1 , 160	18 , 177	12 , 194	3 , 211	1 , 274
13 , 12	17 , 98	2 , 161	19 , 178	13 , 195	4 , 212	
14 , 13	18 , 99	3 , 162	20 , 179	14 , 196	5 , 213	
15 , 14	19 , 100	4 , 163	21 , 180	15 , 197	6 , 214	
16 , 15	20 , 101	5 , 164	22 , 181	16 , 198	7 , 215	
17 , 16	21 , 102	6 , 165	23 , 182	17 , 199	8 , 216	
18 , 17	22 , 103	7 , 166	1 , 183	18 , 200	9 , 217	
* Coordinates of elements with value “1” in submatrix C (23 rows, 274 columns). The coordinates are represented as R, C where R=row and C=column.						

Table 38: LDPC Submatrix D for Subframe 3 *

R , C	R , C
21 , 20	22 , 21
* Coordinates of elements with value “1” in submatrix D (23 row, 23 columns). The coordinates are represented as R, C where R=row and C=column.	

Table 39: LDPC Submatrix E for Subframe 3 *

R , C	R , C	R , C	R , C	R , C	R , C
1 , 229	5 , 233	9 , 237	13 , 241	17 , 245	21 , 249
2 , 230	6 , 234	10 , 238	14 , 242	18 , 246	22 , 250
3 , 231	7 , 235	11 , 239	15 , 243	19 , 247	23 , 251
4 , 232	8 , 236	12 , 240	16 , 244	20 , 248	
* Coordinates of elements with value “1” in submatrix E (23 rows, 251 columns). The coordinates are represented as R, C where R=row and C=column.					

Table 40: LDPC Submatrix T for Subframe 3 * (sheet 1 of 2)

R , C	R , C	R , C	R , C	R , C	R , C	R , C
1 , 1	25 , 25	49 , 49	73 , 73	97 , 97	121 , 121	145 , 145
24 , 1	48 , 25	72 , 49	96 , 73	120 , 97	144 , 121	168 , 145
2 , 2	26 , 26	50 , 50	74 , 74	98 , 98	122 , 122	146 , 146
25 , 2	49 , 26	73 , 50	97 , 74	121 , 98	145 , 122	169 , 146
3 , 3	27 , 27	51 , 51	75 , 75	99 , 99	123 , 123	147 , 147
26 , 3	50 , 27	74 , 51	98 , 75	122 , 99	146 , 123	170 , 147
4 , 4	28 , 28	52 , 52	76 , 76	100 , 100	124 , 124	148 , 148
27 , 4	51 , 28	75 , 52	99 , 76	123 , 100	147 , 124	171 , 148
5 , 5	29 , 29	53 , 53	77 , 77	101 , 101	125 , 125	149 , 149
28 , 5	52 , 29	76 , 53	100 , 77	124 , 101	148 , 125	172 , 149
6 , 6	30 , 30	54 , 54	78 , 78	102 , 102	126 , 126	150 , 150
29 , 6	53 , 30	77 , 54	101 , 78	125 , 102	149 , 126	173 , 150
7 , 7	31 , 31	55 , 55	79 , 79	103 , 103	127 , 127	151 , 151
30 , 7	54 , 31	78 , 55	102 , 79	126 , 103	150 , 127	174 , 151
8 , 8	32 , 32	56 , 56	80 , 80	104 , 104	128 , 128	152 , 152
31 , 8	55 , 32	79 , 56	103 , 80	127 , 104	151 , 128	175 , 152
9 , 9	33 , 33	57 , 57	81 , 81	105 , 105	129 , 129	153 , 153
32 , 9	56 , 33	80 , 57	104 , 81	128 , 105	152 , 129	176 , 153
10 , 10	34 , 34	58 , 58	82 , 82	106 , 106	130 , 130	154 , 154
33 , 10	57 , 34	81 , 58	105 , 82	129 , 106	153 , 130	177 , 154
11 , 11	35 , 35	59 , 59	83 , 83	107 , 107	131 , 131	155 , 155
34 , 11	58 , 35	82 , 59	106 , 83	130 , 107	154 , 131	178 , 155
12 , 12	36 , 36	60 , 60	84 , 84	108 , 108	132 , 132	156 , 156
35 , 12	59 , 36	83 , 60	107 , 84	131 , 108	155 , 132	179 , 156
13 , 13	37 , 37	61 , 61	85 , 85	109 , 109	133 , 133	157 , 157
36 , 13	60 , 37	84 , 61	108 , 85	132 , 109	156 , 133	180 , 157
14 , 14	38 , 38	62 , 62	86 , 86	110 , 110	134 , 134	158 , 158
37 , 14	61 , 38	85 , 62	109 , 86	133 , 110	157 , 134	181 , 158
15 , 15	39 , 39	63 , 63	87 , 87	111 , 111	135 , 135	159 , 159
38 , 15	62 , 39	86 , 63	110 , 87	134 , 111	158 , 135	182 , 159
16 , 16	40 , 40	64 , 64	88 , 88	112 , 112	136 , 136	160 , 160
39 , 16	63 , 40	87 , 64	111 , 88	135 , 112	159 , 136	183 , 160
17 , 17	41 , 41	65 , 65	89 , 89	113 , 113	137 , 137	161 , 161
40 , 17	64 , 41	88 , 65	112 , 89	136 , 113	160 , 137	184 , 161
18 , 18	42 , 42	66 , 66	90 , 90	114 , 114	138 , 138	162 , 162
41 , 18	65 , 42	89 , 66	113 , 90	137 , 114	161 , 138	185 , 162
19 , 19	43 , 43	67 , 67	91 , 91	115 , 115	139 , 139	163 , 163
42 , 19	66 , 43	90 , 67	114 , 91	138 , 115	162 , 139	186 , 163
20 , 20	44 , 44	68 , 68	92 , 92	116 , 116	140 , 140	164 , 164
43 , 20	67 , 44	91 , 68	115 , 92	139 , 116	163 , 140	187 , 164
21 , 21	45 , 45	69 , 69	93 , 93	117 , 117	141 , 141	165 , 165
44 , 21	68 , 45	92 , 69	116 , 93	140 , 117	164 , 141	188 , 165
22 , 22	46 , 46	70 , 70	94 , 94	118 , 118	142 , 142	166 , 166
45 , 22	69 , 46	93 , 70	117 , 94	141 , 118	165 , 142	189 , 166
23 , 23	47 , 47	71 , 71	95 , 95	119 , 119	143 , 143	167 , 167
46 , 23	70 , 47	94 , 71	118 , 95	142 , 119	166 , 143	190 , 167
24 , 24	48 , 48	72 , 72	96 , 96	120 , 120	144 , 144	168 , 168
47 , 24	71 , 48	95 , 72	119 , 96	143 , 120	167 , 144	191 , 168
* Coordinates of elements with value “1” in submatrix T (251 rows, 251 columns). The coordinates are represented as R, C where R=row and C=column.						

LDPC Submatrix T for Subframe 3 * (sheet 2 of 2)

R , C	R , C	R , C	R , C	R , C	R , C	R , C
169 , 169	202 , 179	190 , 190	223 , 200	211 , 211	244 , 221	235 , 235
192 , 169	180 , 180	213 , 190	201 , 201	234 , 211	222 , 222	236 , 236
170 , 170	203 , 180	191 , 191	224 , 201	212 , 212	245 , 222	237 , 237
193 , 170	181 , 181	214 , 191	202 , 202	235 , 212	223 , 223	238 , 238
171 , 171	204 , 181	192 , 192	225 , 202	213 , 213	246 , 223	239 , 239
194 , 171	182 , 182	215 , 192	203 , 203	236 , 213	224 , 224	240 , 240
172 , 172	205 , 182	193 , 193	226 , 203	214 , 214	247 , 224	241 , 241
195 , 172	183 , 183	216 , 193	204 , 204	237 , 214	225 , 225	242 , 242
173 , 173	206 , 183	194 , 194	227 , 204	215 , 215	248 , 225	243 , 243
196 , 173	184 , 184	217 , 194	205 , 205	238 , 215	226 , 226	244 , 244
174 , 174	207 , 184	195 , 195	228 , 205	216 , 216	249 , 226	245 , 245
197 , 174	185 , 185	218 , 195	206 , 206	239 , 216	227 , 227	246 , 246
175 , 175	208 , 185	196 , 196	229 , 206	217 , 217	250 , 227	247 , 247
198 , 175	186 , 186	219 , 196	207 , 207	240 , 217	228 , 228	248 , 248
176 , 176	209 , 186	197 , 197	230 , 207	218 , 218	251 , 228	249 , 249
199 , 176	187 , 187	220 , 197	208 , 208	241 , 218	229 , 229	250 , 250
177 , 177	210 , 187	198 , 198	231 , 208	219 , 219	230 , 230	251 , 251
200 , 177	188 , 188	221 , 198	209 , 209	242 , 219	231 , 231	
178 , 178	211 , 188	199 , 199	232 , 209	220 , 220	232 , 232	
201 , 178	189 , 189	222 , 199	210 , 210	243 , 220	233 , 233	
179 , 179	212 , 189	200 , 200	233 , 210	221 , 221	234 , 234	

* Coordinates of elements with value “1” in submatrix T (251 rows, 251 columns). The coordinates are represented as R, C where R=row and C=column.

Table 41: Number of 1’s in LDPC Submatrix A for Subframe 2

ROW *		COLUMN *	
Row No.	# of 1’s	Column No.	# of 1’s
1 through 50	5	1 through 50	11
51 through 100	6	51 through 200	3
101 through 250	5	201 through 250	11
251 through 300	6	251 through 350	3
301 through 350	4	351 through 400	2
351 through 400	5	401 through 450	11
401 through 450	6	451 through 500	2
451 through 500	5	501 through 600	3
501 through 550	6		

* Row/columns numbers identified as x through y specify the # of 1’s in each column of x through y.
Row/Column numbers not identified here contain zero ones

Table 42: Number of 1’s in LDPC Submatrix B for Subframe 2

ROW *		COLUMN *	
Row No.	# of 1’s	Column No.	# of 1’s
1 through 50	1	1 through 50	2
301 through 350	1		

* Row/columns numbers identified as x through y specify the # of 1’s in each column of x through y.
Row/Column numbers not identified here contain zero ones

Table 43: Number of 1's in LDPC Submatrix C for Subframe 2

ROW *		COLUMN *	
Row No.	# of 1's	Column No.	# of 1's
1 through 50	5	1 through 50	1
		201 through 250	1
		351 through 500	1

* Row/columns numbers identified as x through y specify the # of 1's in each column of x through y. Row/Column numbers not identified here contain zero ones

Table 44: Number of 1's in LDPC Submatrix D for Subframe 2

ROW *		COLUMN *	
Row No.	# of 1's	Column No.	# of 1's
1 through 50	1	1 through 50	1

* Row/columns numbers identified as x through y specify the # of 1's in each column of x through y. Row/Column numbers not identified here contain zero ones

Table 45: Number of 1's in LDPC Submatrix E for Subframe 2

ROW *		COLUMN *	
Row No.	# of 1's	Column No.	# of 1's
1 through 50	1	501 through 550	1

* Row/columns numbers identified as x through y specify the # of 1's in each column of x through y. Row/Column numbers not identified here contain zero ones

Table 46: Number of 1's in LDPC Submatrix T for Subframe 2

ROW *		COLUMN *	
Row No.	# of 1's	Column No.	# of 1's
1 through 50	1	1 through 500	2
51 through 550	2	501 through 550	1

* Row/columns numbers identified as x through y specify the # of 1's in each column of x through y. Row/Column numbers not identified here contain zero ones

Table 47: Number of 1's in LDPC Submatrix A for Subframe 3

ROW *		COLUMN *	
Row No.	# of 1's	Column No.	# of 1's
1 through 2	4	1 through 19	11
3 through 20	5	20 through 88	3
21 through 22	6	89 through 90	9
23 through 26	5	91 through 106	10
27 through 44	6	107 through 110	11
45 through 61	5	111 through 111	10
62 through 65	4	112 through 113	2
66 through 67	5	114 through 157	3
68 through 69	4	158 through 180	2
70 through 88	3	181 through 182	8
89 through 113	4	183 through 184	9
114 through 116	5	185 through 196	7
117 through 135	6	197 through 200	8
136 through 136	5	201 through 203	7
137 through 157	4	204 through 226	2
158 through 159	3	227 through 249	3
160 through 169	5	250 through 251	2
170 through 173	4	252 through 272	3
174 through 217	5	273 through 273	2
218 through 221	4	274 through 274	1
222 through 228	5		

229 through 230	4		
231 through 249	5		
250 through 251	4		
* Row/columns numbers identified as x through y specify the # of 1's in each column of x through y.			

Table 48: Number of 1's in LDPC Submatrix B for Subframe 3

ROW *		COLUMN *	
Row No.	# of 1's	Column No.	# of 1's
1 through 20	1	1	1
22 through 23	1	2 through 21	2
139 through 159	1	22 through 23	1
* Row/columns numbers identified as x through y specify the # of 1's in each column of x through y.			

Table 49: Number of 1's in LDPC Submatrix C for Subframe 3

ROW *		COLUMN *	
Row No.	# of 1's	Column No.	# of 1's
1 through 20	5	1 through 19	1
21 through 22	4	89 through 111	1
23	5	158 through 226	1
		273 through 274	1
* Row/columns numbers identified as x through y specify the # of 1's in each column of x through y.			

Table 50: Number of 1's in LDPC Submatrix D for Subframe 3

ROW *		COLUMN *	
Row No.	# of 1's	Column No.	# of 1's
21 through 22	1	20 through 21	1
* Row/columns numbers identified as x through y specify the # of 1's in each column of x through y.			

Table 51: Number of 1's in LDPC Submatrix E for Subframe 3

ROW *		COLUMN *	
Row No.	# of 1's	Column No.	# of 1's
1 through 23	1	229 through 251	1
* Row/columns numbers identified as x through y specify the # of 1's in each column of x through y.			

Table 52: Number of 1's in LDPC Submatrix T for Subframe 3

ROW *		COLUMN *	
Row No.	# of 1's	Column No.	# of 1's
1 through 23	1	1 through 228	2
24 through 251	2	229 through 251	1
* Row/columns numbers identified as x through y specify the # of 1's in each column of x through y.			